



ULTRACARE

At the Cutting Edge of Industry

SET

SINGLE END TENONER

INSTRUCTION MANUAL No.3021/1

PREFACE

IMPORTANT

IT IS OUR POLICY AND THAT OF OUR SUPPLIERS TO CONSTANTLY REVIEW THE DESIGN AND CAPACITY OF OUR PRODUCTS. WITH THIS IN MIND WE WOULD REMIND OUR CUSTOMERS THAT WHILE THE DIMENSIONS AND PERFORMANCE DATA CONTAINED HEREIN ARE CURRENT AT THE TIME OF GOING TO PRESS, IT IS POSSIBLE THAT DUE TO THE INCORPORATION OF THE LATEST DEVELOPMENTS TO ENHANCE PERFORMANCE, DIMENSIONS AND SUPPLIERS MAY VARY FROM THOSE ILLUSTRATED

THIS MANUAL IS WRITTEN AS A GENERAL GUIDE. A TYPICAL MACHINE IS SHOWN TO ILLUSTRATE THE MAIN FEATURES.

Failure to comply with instructions in this book may invalidate the guarantee

**MANUFACTURERS E.C. DECLARATION
OF CONFORMITY**

The following machine has undergone "Conformity Assessment" and has undergone Self Assessment in accordance with:-

Schedule IV of the Supply of Machinery (Safety) Regulations 1992
and Amendment No. 2063

COMPANY

Wadkin Ultracare Limited
Franks Road
Hilltop Industrial Park
Bardon
Leicestershire
LE67 1TT

RESPONSIBLE PERSON

Mr J P Smith (Director)

MACHINE DESCRIPTION

TYPE Single End Tenoner

MODEL SET

DIRECTIVES COMPLIED WITH

Supply of Machinery (Safety) Regulations 1992
Amendment No. 2063 1994
Draught Proposal CEN/TC 142
ISO 9001 Part 1

**SIGNED ON BEHALF OF WADKIN
ULTRACARE LTD.**



.....

**BE CAREFUL
THIS MACHINE CAN BE DANGEROUS
IF IMPROPERLY USED**

Always use guards.
Keep clear until rotation has ceased.
Always operate as instructed
and in accordance with good practice.
Read instruction manual before installing,
operating or maintaining machine.

*Manufactured by : WADKIN PLC
Franks Road
Hilltop Industrial Park
Bardon Hill
Coalville, LE67 1TT
England*

*Telephone No. : +44(0)116 2769111
Fax No. : +44(0)116 2598138*



1.0	INDEX	Pages 1/1
2.0	SAFETY	Pages 2/1 to 2/2
2.1	Health & Safety Statement	Page 2/1
2.2	Safety Instructions	Page 2/2
3.0	SPECIFICATIONS	Pages 3/1
4.0	ASSEMBLY INSTRUCTIONS	Pages 4/1 to 4/9
4.1	Standard Items Despatched with Machine	Page 4/6
4.2	Slings	Page 4/6
4.3	Foundation	Page 4/6
4.4	Cleaning	Page 4/6
4.5	Electrical	Page 4/6
4.5.1	Wiring Connections	Page 4/6
4.5.2	Fuse Lists	Page 4/7
4.5.2.a)	Fuse List - 2 Heads	Page 4/7
4.5.2.b)	Fuse Lists - 2 Heads and Cut Off Saw	Page 4/7
4.5.3	Wiring Diagrams	Page 4/8
4.6	Dust Extraction Details	Page 4/8
5.0	CONTROLS	Pages 5/1 to 5/12
5.1	Table Rise & Fall	Page 5/1
5.2	Bottom Head Lateral Adjustment	Page 5/1
5.3	Top Head Vertical Adjustment	Page 5/1
5.4	Cut Off Saw Lateral Adjustment (when fitted)	Page 5/1
5.5	Work Piece Clamp	Page 5/1
5.6	Front End Stop Positioning	Page 5/7
5.7	Turnover Shoulder Stop Setting	Page 5/7
5.8	Backing Piece Fitting	Page 5/7
5.9	Mitre Fence	Page 5/8
5.10	Electrical Controls	Page 5/8
5.11	Variable Speed Traverse Control	Page 5/8
5.12	Adjustable Stops	Page 5/8
6.0	USE OF MACHINE	Pages 6/1 to 6/4
6.1	Instructions to Set Size of Tenon	Page 6/1
6.2	Instructions to Fit Scribing Cartridges	Page 6/1
6.3	Instructions to Fit Cut Off Saw (when fitted)	Page 6/1
7.0	MAINTENANCE	Pages 7/1 to 7/4
7.1	Lubrication	Page 7/1
7.2	Belt Change on Variable Speed Traverse	Page 7/1
8.0	SPARES	Pages 8/1 to 8/2
8.1	Instruction for Ordering Spare Parts	Page 8/1
9.0	TOOLING	Pages 9/1 to 9/4
9.1	Instructions for Square and Scribing Cartridges	Page 9/1
9.2	Instructions for Square Cutters	Page 9/1
9.3	Instructions for Scribing Cutters	Page 9/1
9.4	Instructions for Square and Scribing Cartridges	Page 9/1

2.1

HEALTH & SAFETY**SAFETY OF WOODWORKING MACHINES**

Woodworking machines can be dangerous if improperly used. The wide range of work of which they are capable, requires adequate safeguarding arrangements against possible hazards.

Many injuries to machinists are caused by carelessness or failure to use the guards provided or to adjust them correctly.

Wadkin plc supply machinery designed for maximum safety which they believe, as a result of thorough testing, minimizes the risks inevitable in their use. It is the users responsibility to see that the following rules are complied with to ensure safety at work:

- 1) The operation of the machine should conform to the requirements of the UK Woodworking Machines Regulations 1974. All guards should be used and adjusted correctly.
- 2) Safe methods of working only should be adopted as given in BS.6854 Part 1, "Safeguarding Woodworking Machines" (UK only) and subsequent parts for specific machines (obtainable from Her Majesty's Stationery Office) and as advised by Wadkin plc.
- 3) Only personnel trained in the safe use of a machine should operate it.
- 4) Before making adjustments or clearing chips, etc., electrically isolate machine and ensure all movements have ceased.
- 5) All tools and cutters must be securely fixed and the correct speed selected.

Safety is our watchword, but the user must comply with the above rules in his own interest. We would be pleased to advise on the safe use of our products.

Wadkin Leicester

Green Lane Works, Leicester LE5 4PF, England.
Telephone: 0533 769111 Telex: 34646 Wadkin G.
Fax: 0533 742310

2.2 SAFETY INSTRUCTIONS

Carefully read instruction manual with particular reference to the following instructions:-

- a) Slinging, ie, safe lifting limits for slings, etc.
- b) Installation and foundation, ie, safe working area of machine, bolt positions, etc.
- c) Wiring details, ie, connection of machine to mains supply, fuse details, etc.
- d) Machine controls and operating instructions.

Ensure tooling is of the correct type for use with the machine and cutters are securely fixed in position.

Select correct spindle speed and feed rate relevant to the tooling being used.

Set all guards correctly and ensure they are securely fixed in accordance with the current regulations.

Use suitable jigs, fixtures and feeding devices etc., (push stick, etc.,) where appropriate.

Refer to BS.6854, Part 1, "Safeguarding Woodworking Machines" UK market and subsequent parts for specific machines for safe working practices.

During Machining

Wear suitable protective equipment, where necessary, eg, goggles, ear defenders and dust mask.

Ensure all moving parts of the machine are stationary before setting, cleaning or making any adjustments.

Report immediately to a person in authority any machine malfunction or operator hazard. Do not attempt to repair the machine unless authorised to do so.

Ensure machine is electrically isolated before any maintenance/cleaning work commences.

NOISE LEVELS

This machine, under certain conditions, will emit noise levels in excess of 85dB(a).

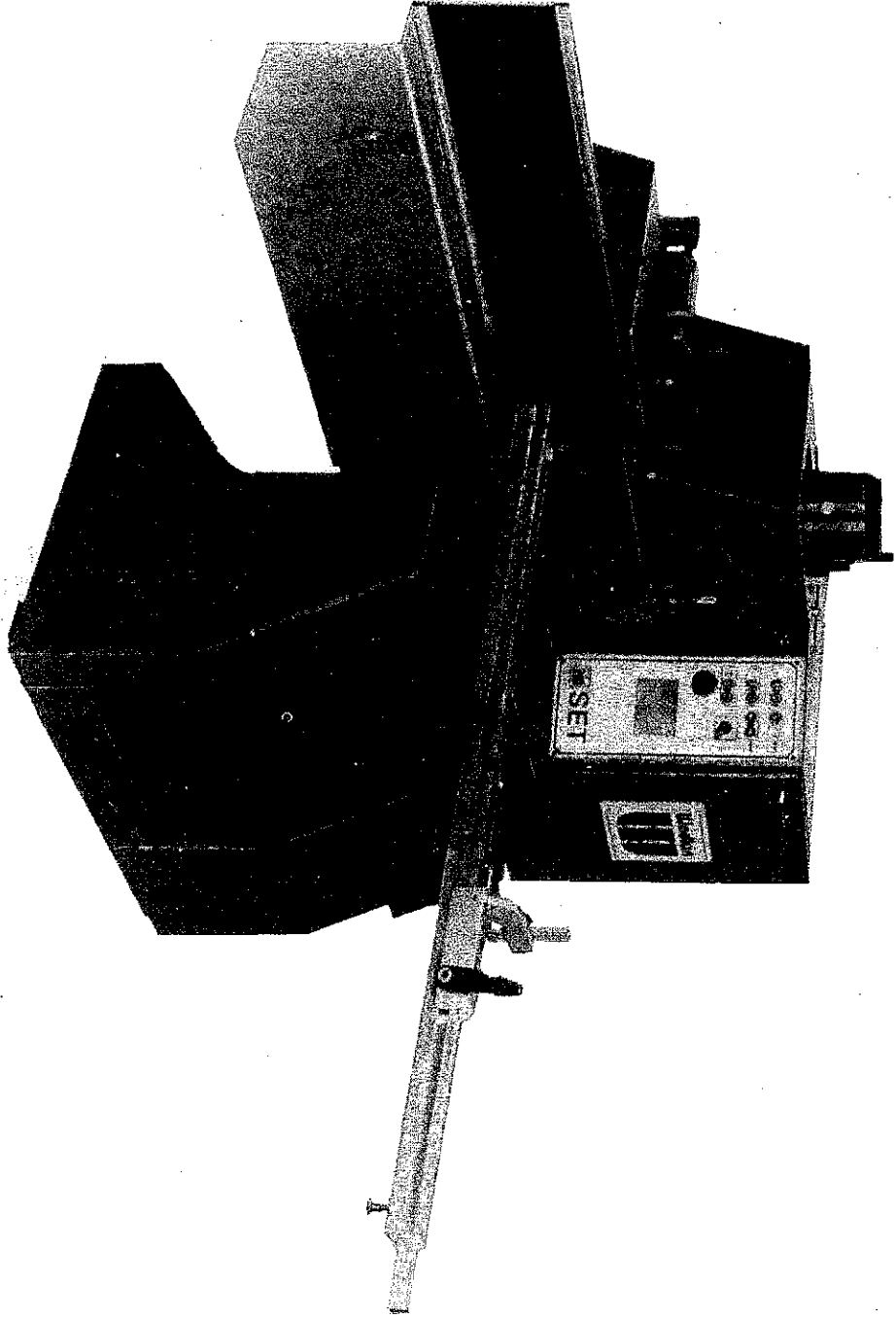
Noise levels will be affected by the environment in which the machine operates the timber being machined, tooling, machine setting and dust extraction.

Further information available from Wadkin on request.

As a manufacturer it is Wadkin's policy to reduce the noise level as far as it is practicable.

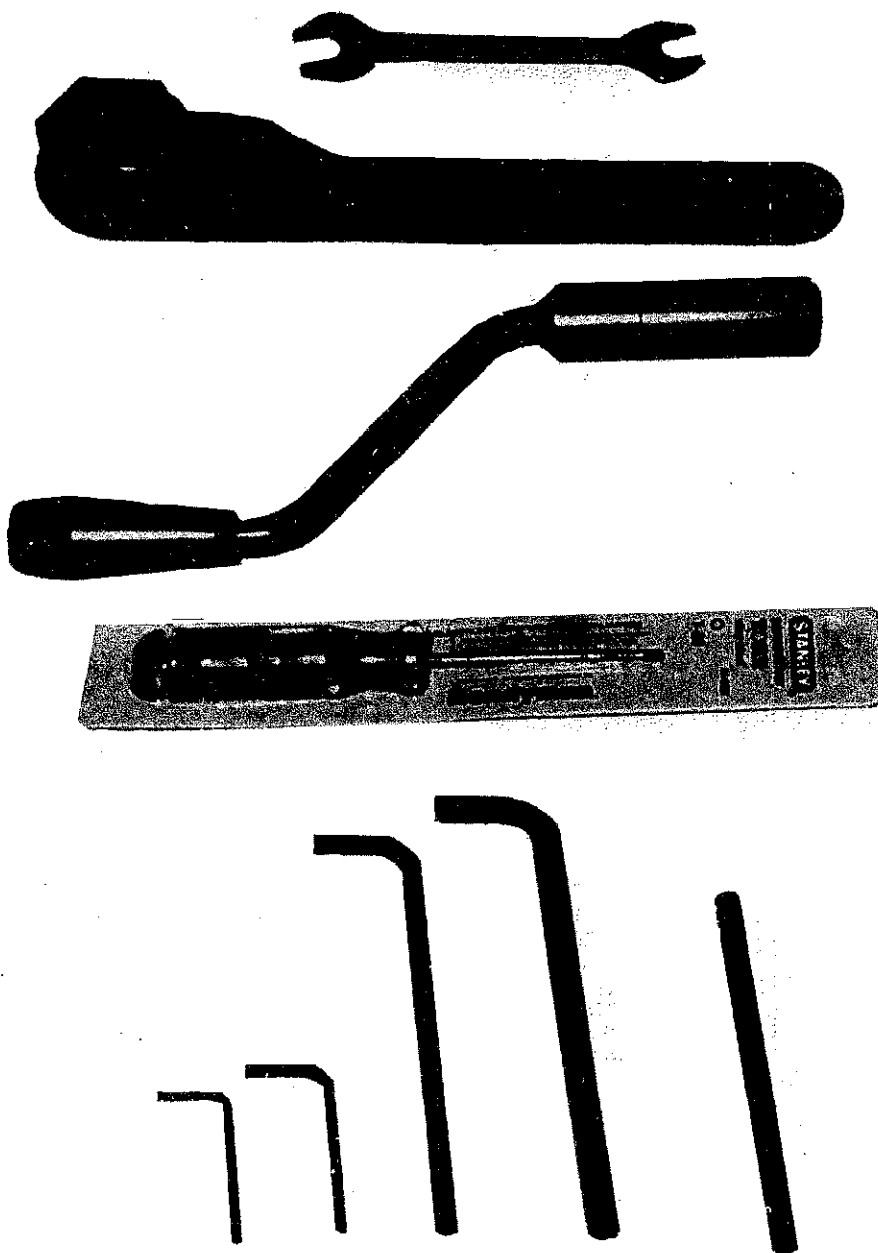
3.0 SPECIFICATION - SET

Maximum Timber Thickness	150mm
Maximum Timber Width	350mm
Maximum Tenon Length	150mm
Maximum Tenon Thickness	32mm
Shoulder Stagger	32mm
Maximum Depth Bottom Shoulder	60mm
Maximum Diameter Tenon Cutters	322mm
a) Tenon Spindle Diameter	35mm
b) Tenon Spindle Length	72mm
Speed Tenon Heads	3000rpm - 50 cycles 3600rpm - 60 cycles
Power Tenon Cutterheads	4kw (5.5hp)
Infinitely Variable Traverse Speed	1.0 - 8.0m/min
Length of Graduated Fence Bar	1500mm
Power of Cut-Off Saw (Optional Extra)	2.2KW (3 HP)
Maximum Diameter of Cut-Off Saw	350mm
Bore of Cut-Off Saw	30mm
Dia Dust Extraction Outlet	150mm
Extraction Volume Requirement	463LPS at 100mm Water Gauge (982CFM)
Approximate net and gross weight	690Kg



SET - SINGLE END TENONER

FIG. 1

4.1 Standard Items Despatched with Machine

- 1 - 17/19mm A/F Spanner
- 1 - SET 128 Spanner
- 1 - Handle 1079/938
- 1 - T20 Torx Screw Driver
- 1 - 4mm Allen Key
- 1 - 5mm Allen Key
- 1 - 8mm Long Arm Allen Key
- 1 - 10mm Long Arm Allen Key
- 1 - 10mm Toggle Bar
(required with cut-off saw)

FIG.2

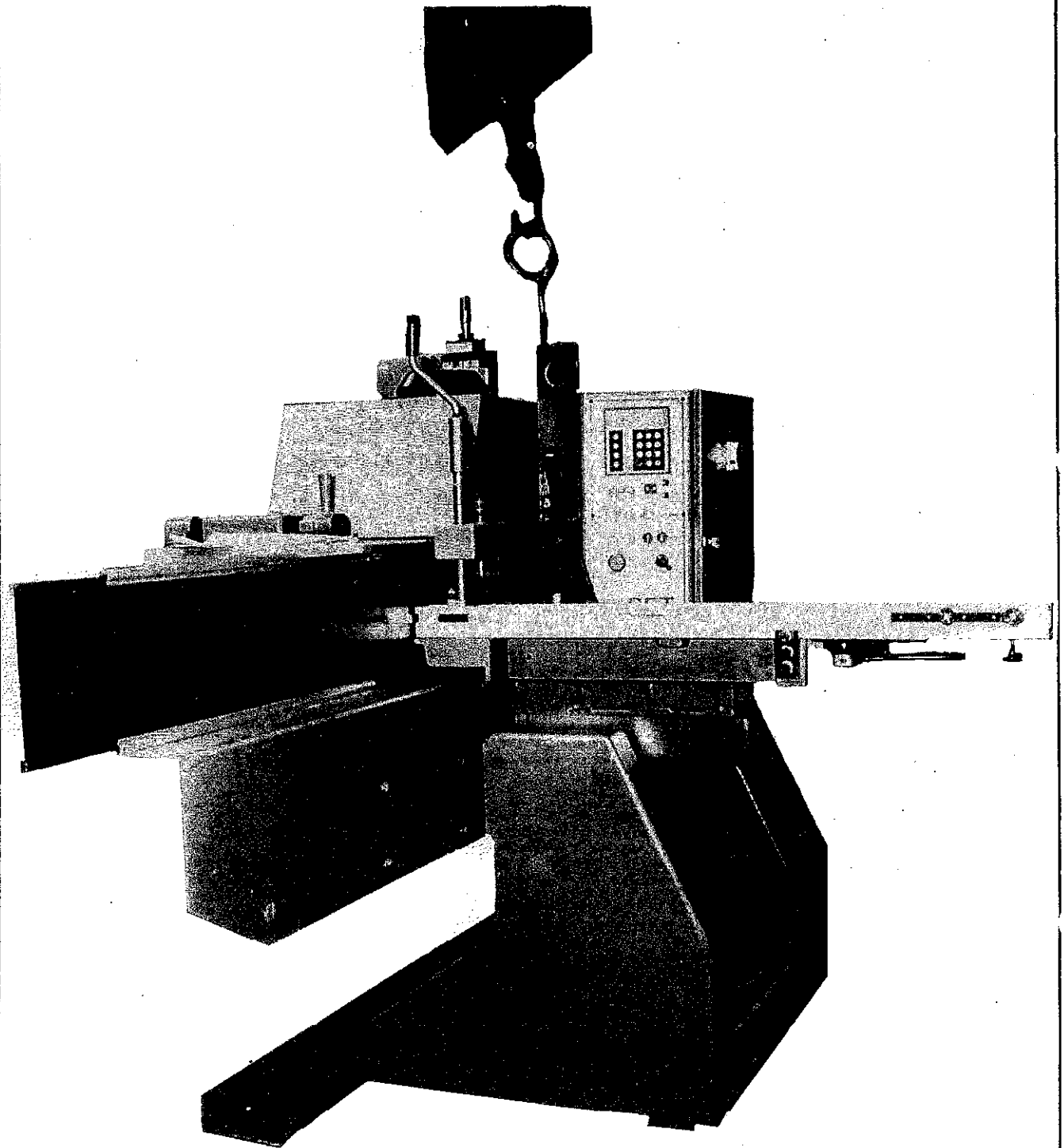
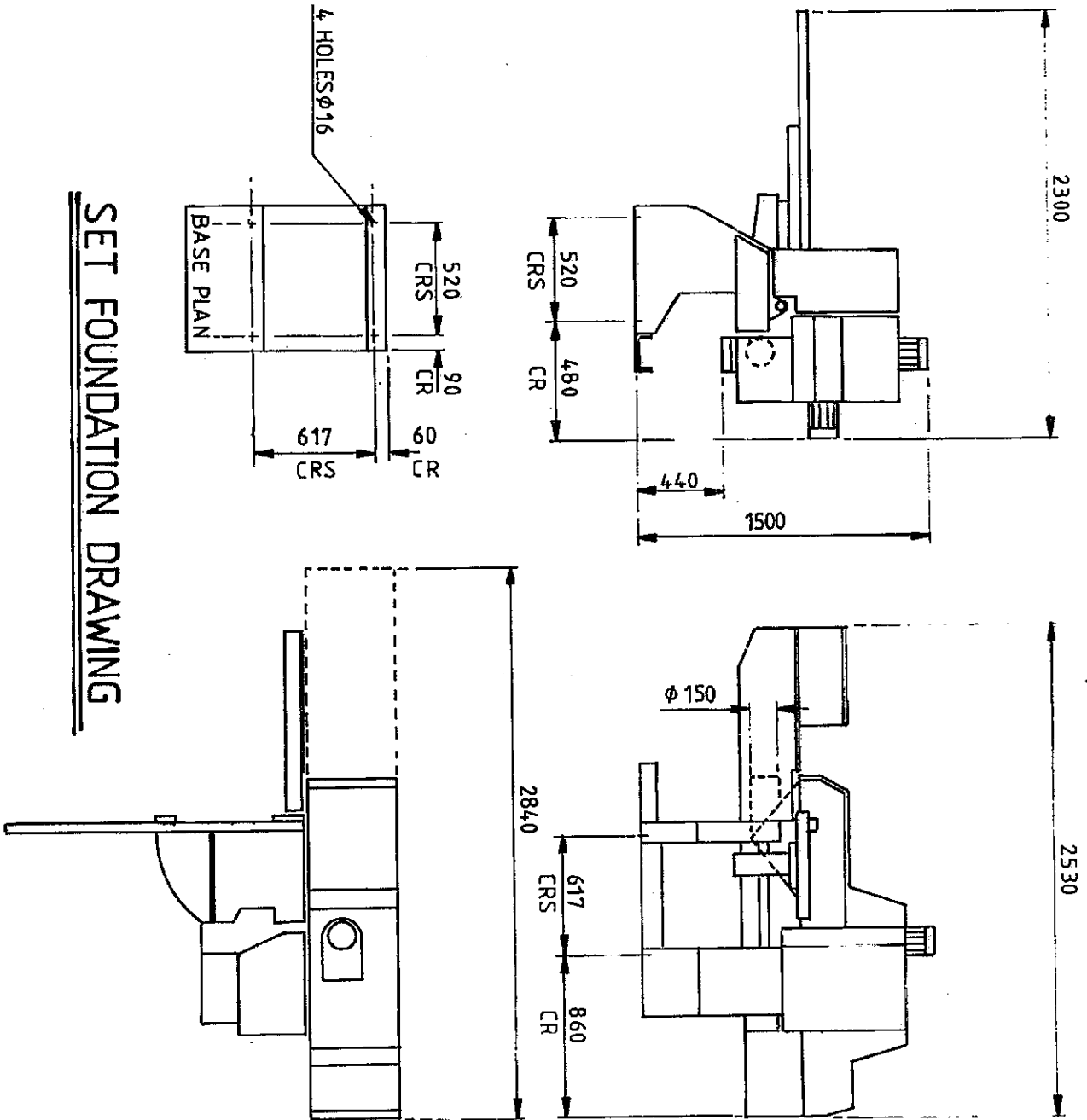


FIG. 3



SET FOUNDATION DRAWING

FIG. 4

DIAGRAM OF LEVELLING SCREW
INSIDE MACHINE BASE.

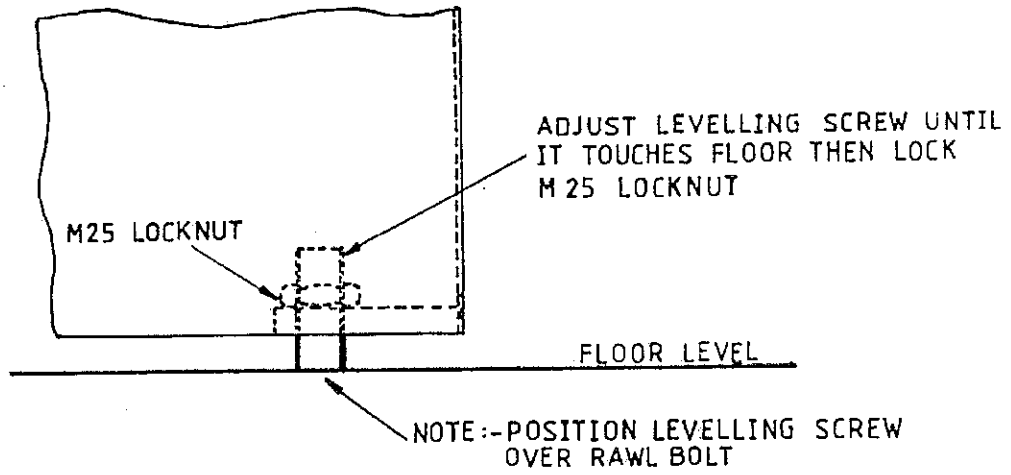


FIG.5

4.0 ASSEMBLY INSTRUCTIONS

4.1 Standard Items Despatched with Machine

A set of operational spanners are despatched with the machine, see FIG.2 for details.

4.2 Slinging

Always use a sling within safe working load of machine weight.

Approximate net & gross weight of machine - 700 KG

Attached slings to lifting hook in FIG.3 ensuring damage will not be caused to machine during slinging operations.

IMPORTANT: DO NOT WALK OR STAND UNDER MACHINE DURING SLINGING OPERATION.

4.3 Foundation

The machine should be so placed that the traffic of men and materials to and from it fits smoothly into the general scheme of traffic. It should also not be necessary for the operator to stand in or near an aisle so as to cause a hazard. The minimum clearance on each working side of the machine should be at least 1 metre greater than the largest material worked on the machine.

Ensure floor is level, then mark to suit 4 - M12 rawlbolts, refer to foundation plan FIG.4. Drill floor to suit rawlbolts. These bolts are not supplied with the machine, but can be supplied at an additional charge. To obtain access to foundation bolts, remove the plinth cover fitted between the support legs. Position machine over rawl bolts and adjust levelling screw until it comes in contact with the floor, see FIG.5. Fully tighten rawl bolts. Replace plinth cover.

4.4 Cleaning

Remove protective coating from bright parts by applying a cloth soaked in paraffin or other solvents.

4.5 Electrical

4.5.1 Wiring Connections

The motor and control gear have been wired in before despatch, all that is required is to connect the power supply to the starter or isolating switch when fitted.

Points to note when connecting power supply:-

- a) Check the voltage, phase and frequency correspond to those on the motor plate.

- b) It is important that the correct cable is used to give the correct voltage to the starters, as running on low voltage will damage the motors.
- c) Check the main line fuses are of the correct capacity. See fuse list. (Refer to 4.5.2)
- d) Connect the line leads to the appropriate terminals. See wiring diagrams. (Refer to 4.5.3)
- e) Check all connections are sound.
- f) Check rotation of all motors for the correct direction. If these are incorrect, reverse any two of the incoming mains leads connections.

4.5.2 Fuse List

4.5.2.a) Fuse List - 2 Heads

Direct on Line

<u>Voltage</u>	<u>Phase</u>	<u>KW</u>	<u>SWG Tinned Copper Wire</u>	<u>Starting Amps</u>
220	3	8	14	100
380	3	8	15	65
415	3	8	17	60

Star Delta

<u>Voltage</u>	<u>Phase</u>	<u>KW</u>	<u>SWG Tinned Copper Wire</u>	<u>Starting Amps</u>
220	3	8	17	45
380	3	8	18	30
415	3	8	19	25

USA & Canada

<u>Voltage</u>	<u>Phase</u>	<u>HP</u>	<u>Cartridge Fuse (Circuit Protection)</u>
220/230	3	12	85
440	3	12	42
575	3	12	30

4.5.2.b) Fuse List - 2 Heads and Cut Off Saw

Direct on Line

<u>Voltage</u>	<u>Phase</u>	<u>KW</u>	<u>SWG Tinned Copper Wire</u>	<u>Starting Amps</u>
220	3	10.2	14	115
380	3	10.2	15	80
415	3	10.2	17	75

Star Delta

<u>Voltage</u>	<u>Phase</u>	<u>KW</u>	<u>SWG Tinned Copper Wire</u>	<u>Starting Amps</u>
220	3	10.2	17	53
380	3	10.2	18	38
415	3	10.2	19	33

USA & Canada

<u>Voltage</u>	<u>Phase</u>	<u>HP</u>	<u>Cartridge Fuse (Circuit Protection)</u>
220/230	3	15	100
440	3	15	50
575	3	15	40

4.5.3 Wiring Diagrams

See wiring diagrams enclosed in electrical control cabinet.

4.6 Dust Extraction Details

The extraction outlet is situated at the front of the moving head of the machine. The outlet size is 150mm and should be connected to a flexible extraction hose from the main plant. The volume of air to be extracted is 463 LPS (982 CFM) with a velocity of 26 MPS (5,000 ft per min).

5.0 CONTROLS

5.1 Table Rise & Fall

The table has vertical adjustment of 60mm and is controlled from the rise and fall shaft 'A', FIG.6.

The height of the table relative to the bottom tenon head is shown on the digital readout 'B', this indicates the height of the shoulder of the tenon.

The size can be entered on the 'Record Card' under dimension 'C', FIG.23 for future reference, to enable the job to be repeated at any time.

5.2 Bottom Tenon Head Lateral Adjustment

The bottom tenon head has lateral adjustment relative to the top tenon head of 32mm either side of the top tenon head position. The adjustment is by shaft 'C', FIG.7 and can be locked in position by locking handle 'D'

The digital readout 'E' indicates the stagger of the shoulders of the tenon produced.

The size can be entered on the "Record Card" under dimension 'B', FIG.23, for future reference to enable the job to be repeated at any time.

5.3 Top Tenon Head Vertical Adjustment

The top tenon head has vertical adjustment relative to the bottom head and has an adjustment of 100mm. The adjustment is by shaft 'K', FIG.8 and can be locked in position by locking handle 'L'.

The digital readout 'M' indicates the thickness of the tenon being produced.

The size can be entered on the "Record Card" under dimension 'A', FIG.23, for future reference to enable the job to be repeated at any time.

5.4 Cut-Off Saw Lateral Adjustment (When Fitted)

The cut-off saw has lateral adjustment of 150mm. The adjustment is by shaft 'F', FIG.7, and can be locked in position by locking handle 'G'. The digital readout 'H' indicates the length of tenon relative to the square shoulder produced by the top tenon head.

The size can be entered on the "Record Card" under dimension 'D', FIG.23, for future reference to enable the job to be repeated at any time.

5.5 Work Piece Clamp

The work piece is held in position by a single hand operated clamping mechanism. Vertical adjustment to the clamping mechanism is by screw 'N', FIG.9. Position clamp mechanism to the required height and lock material securely to table by lever 'P'.

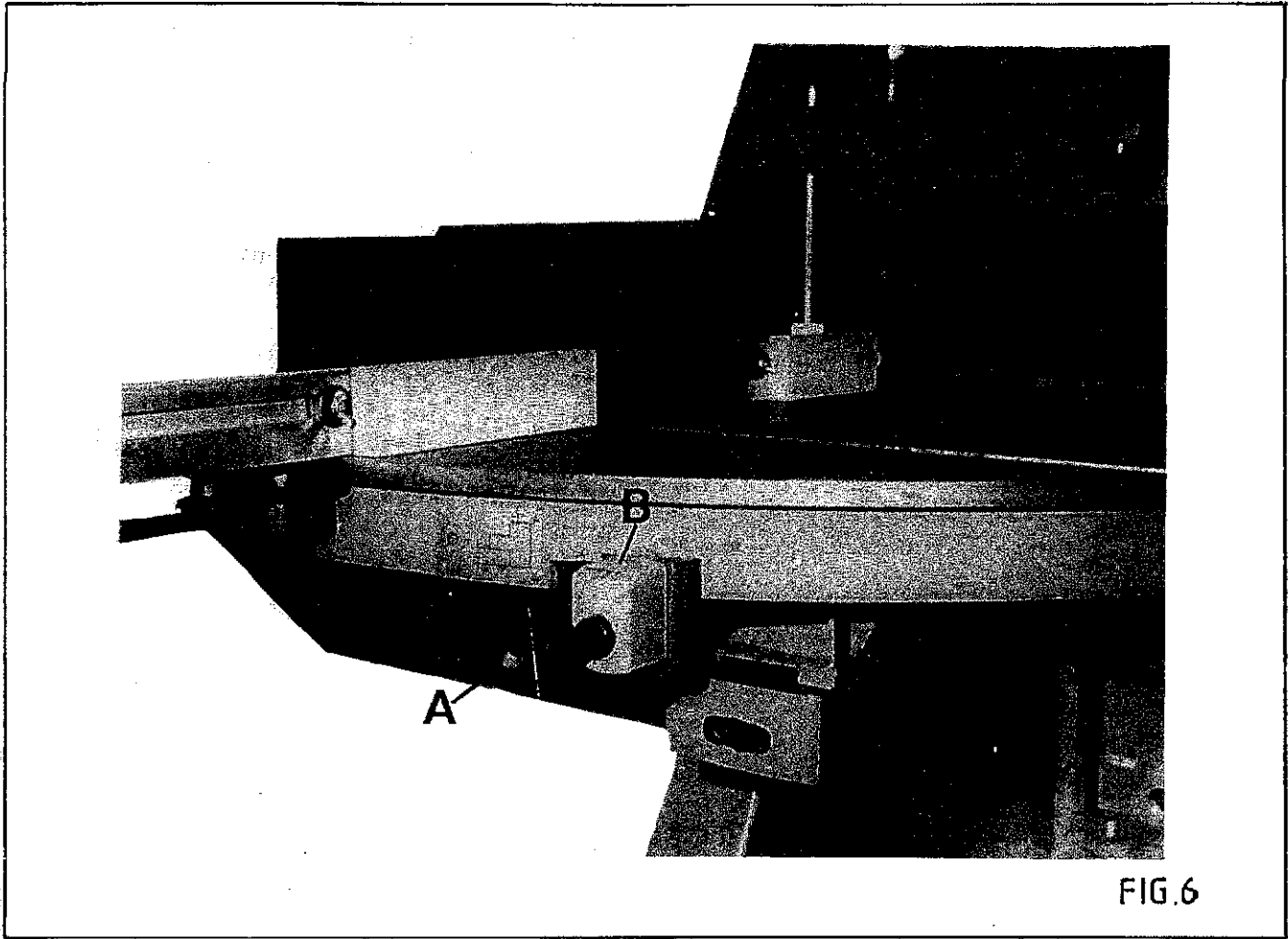


FIG. 6

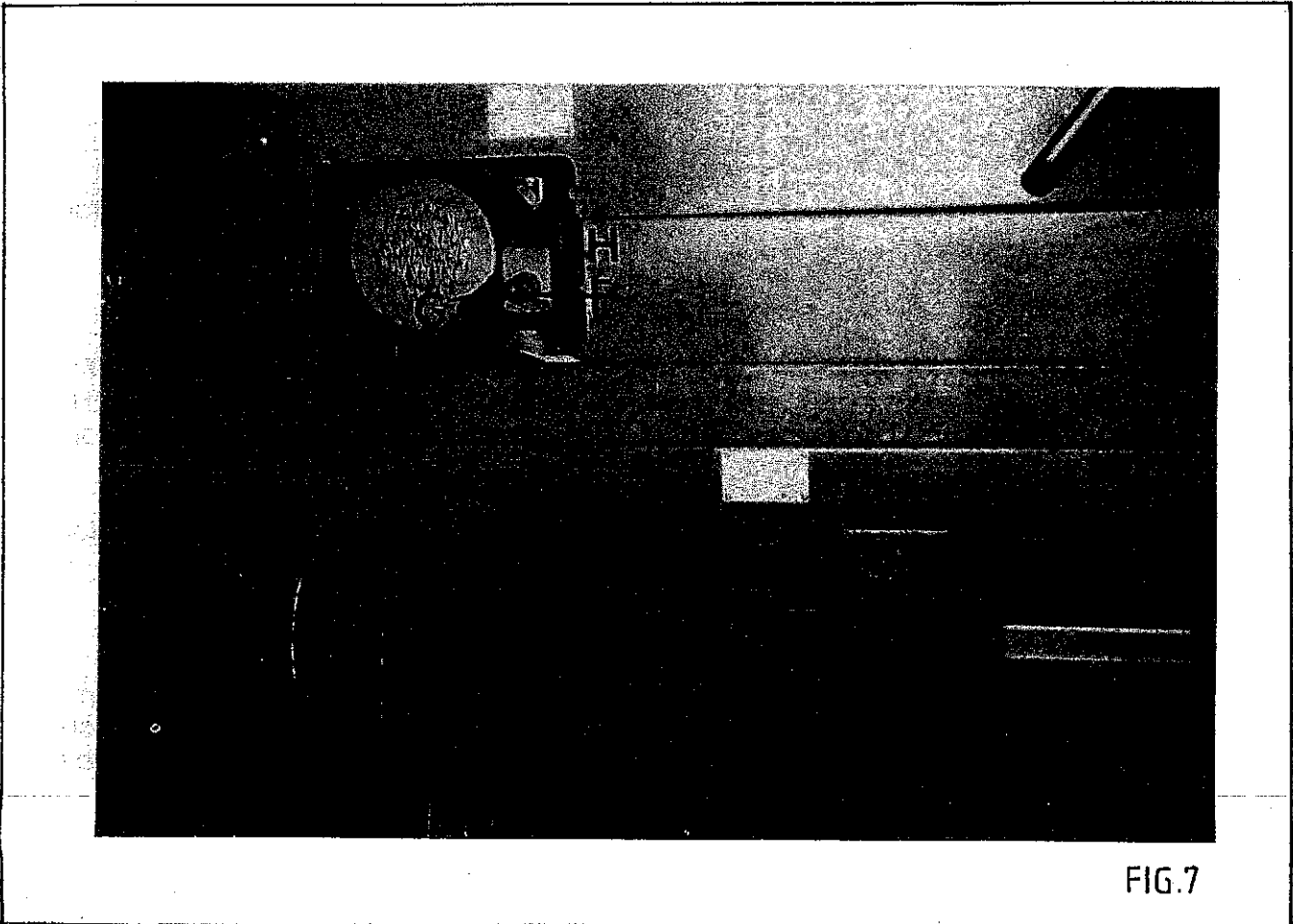


FIG. 7

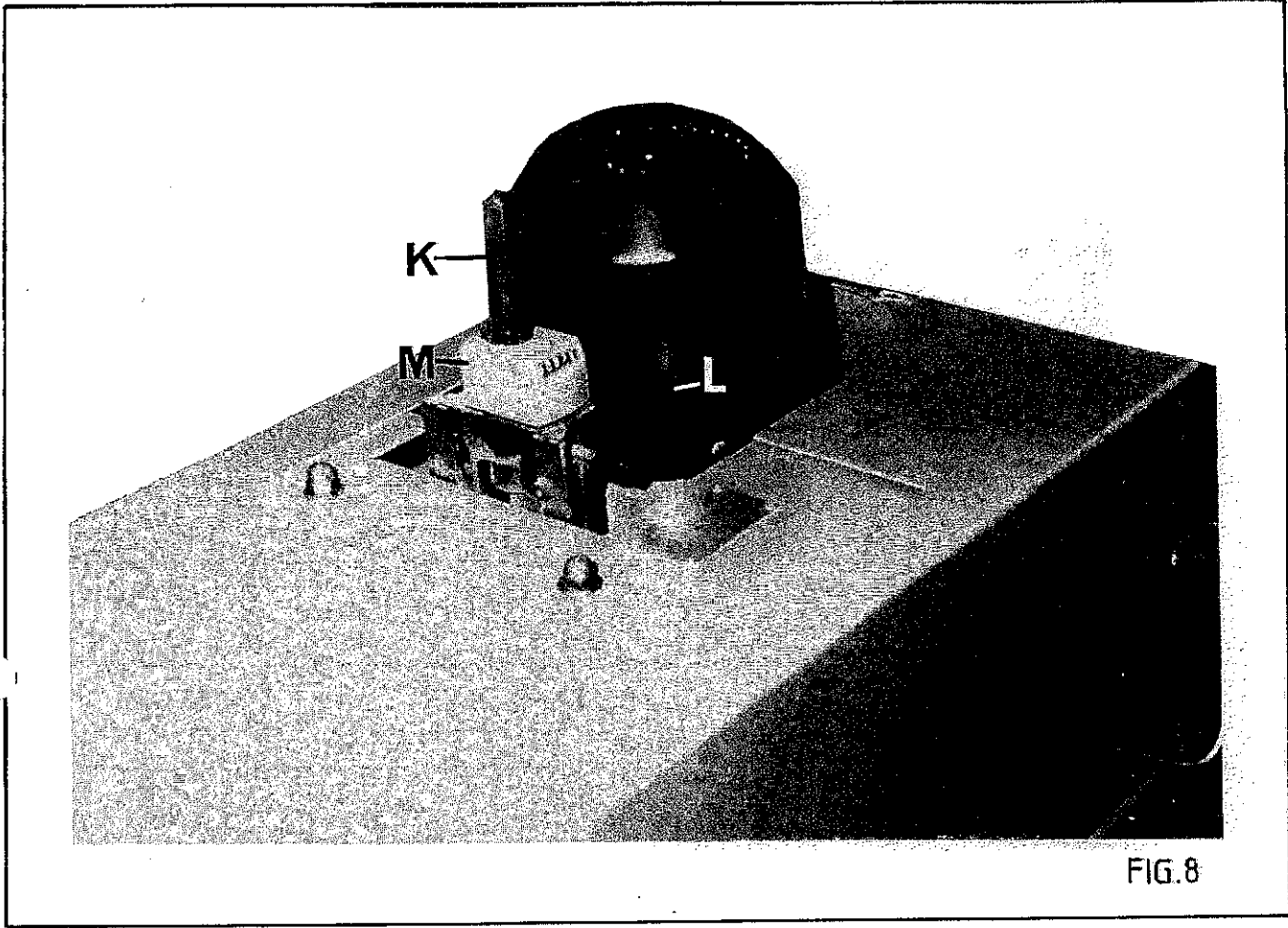


FIG. 8

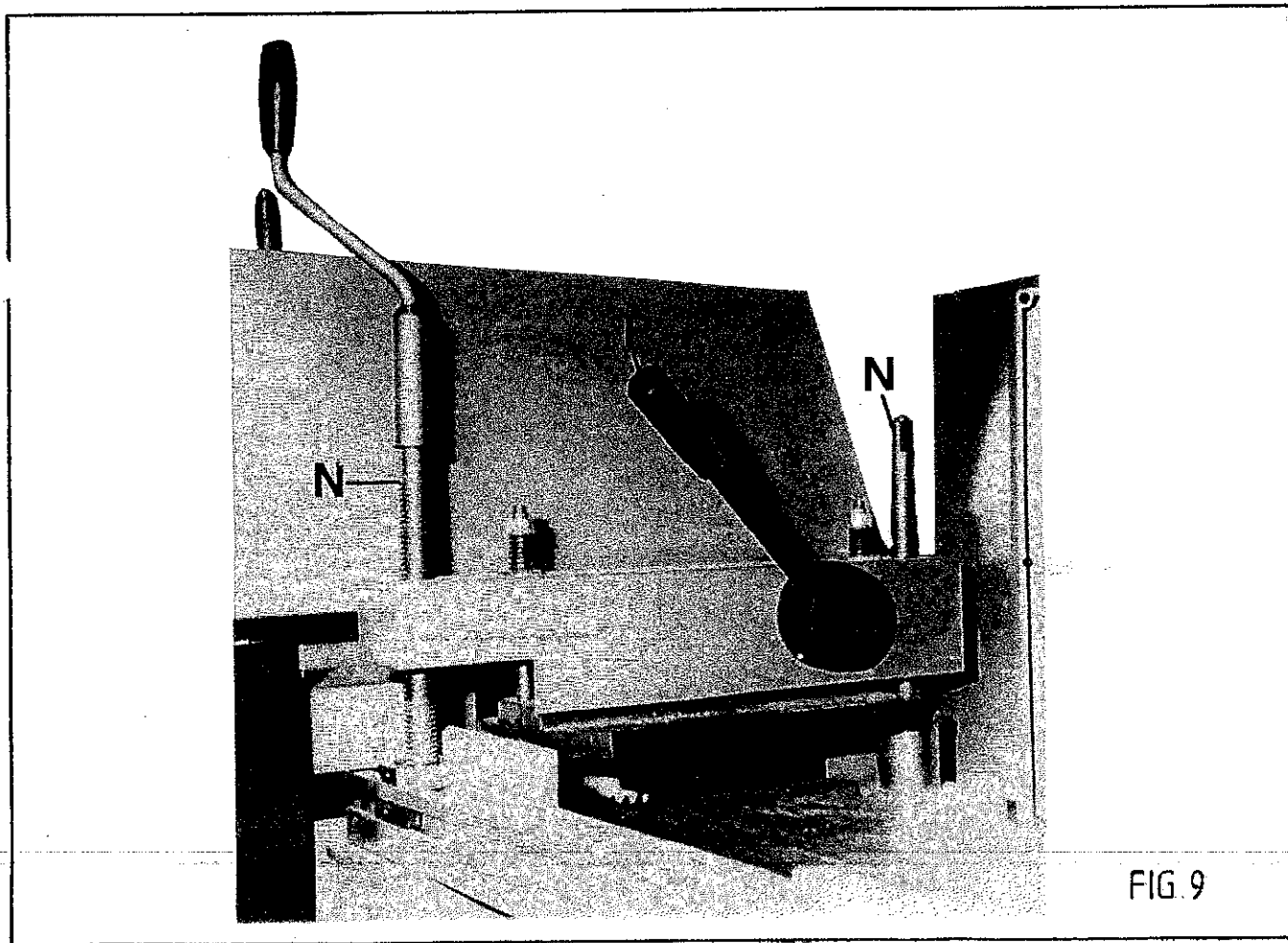


FIG. 9

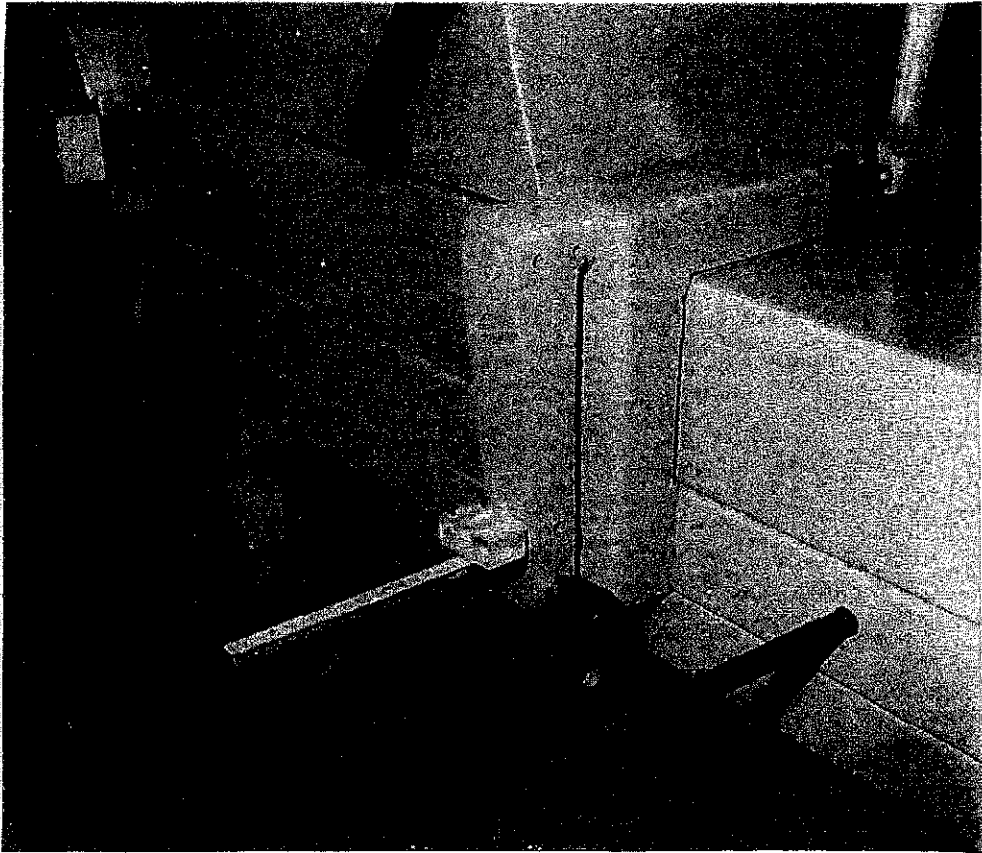


FIG. 10

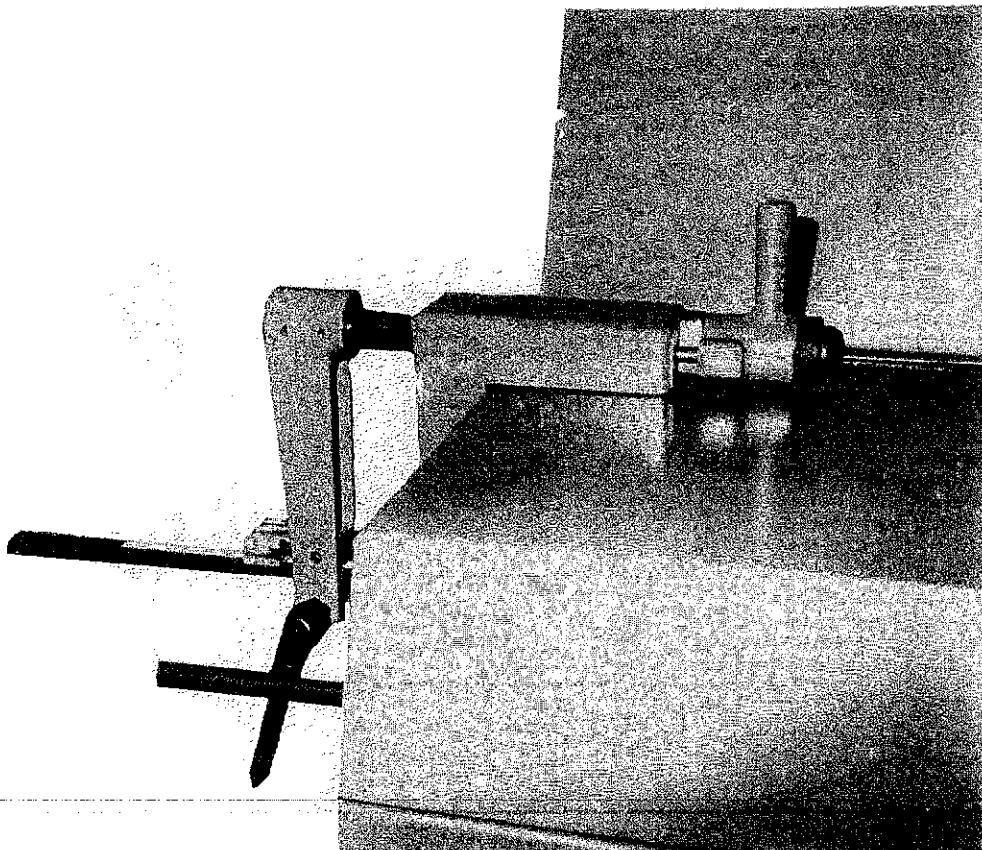


FIG. 11

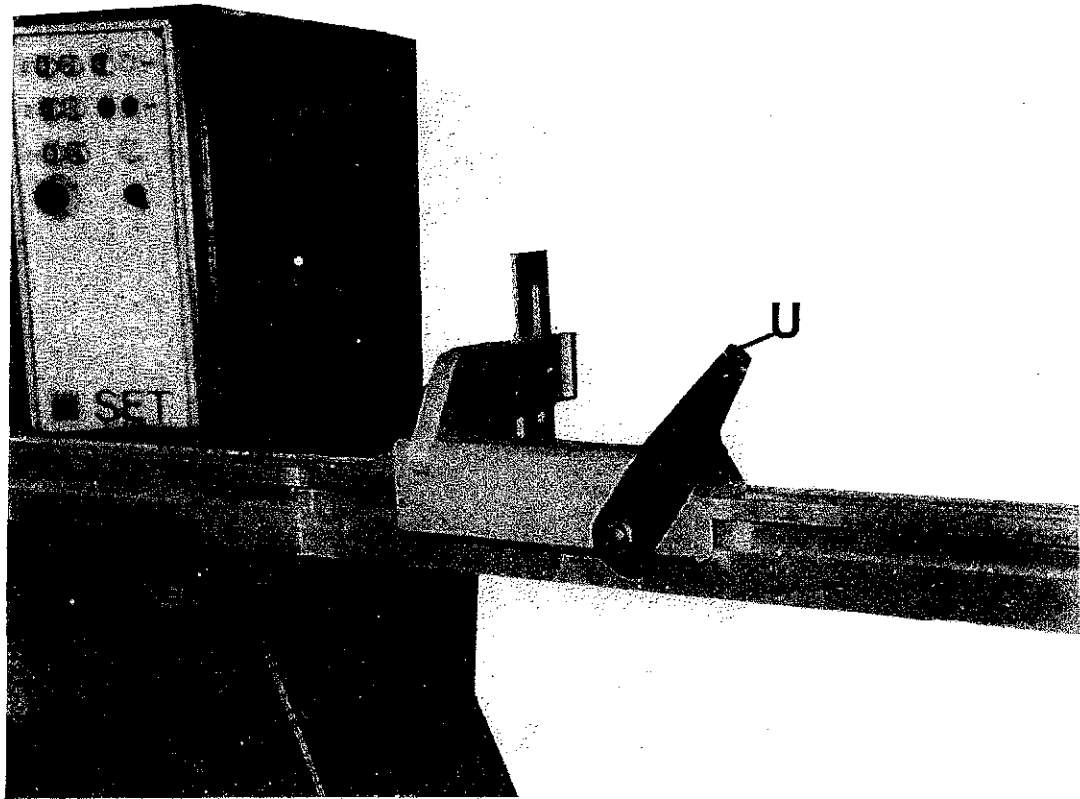


FIG.12

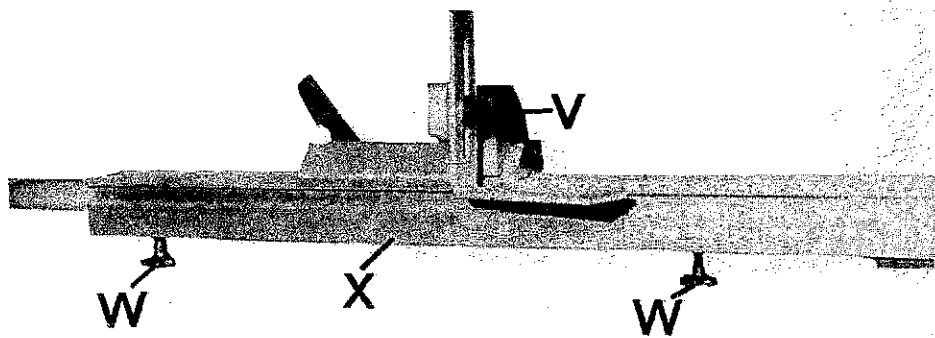


FIG.13

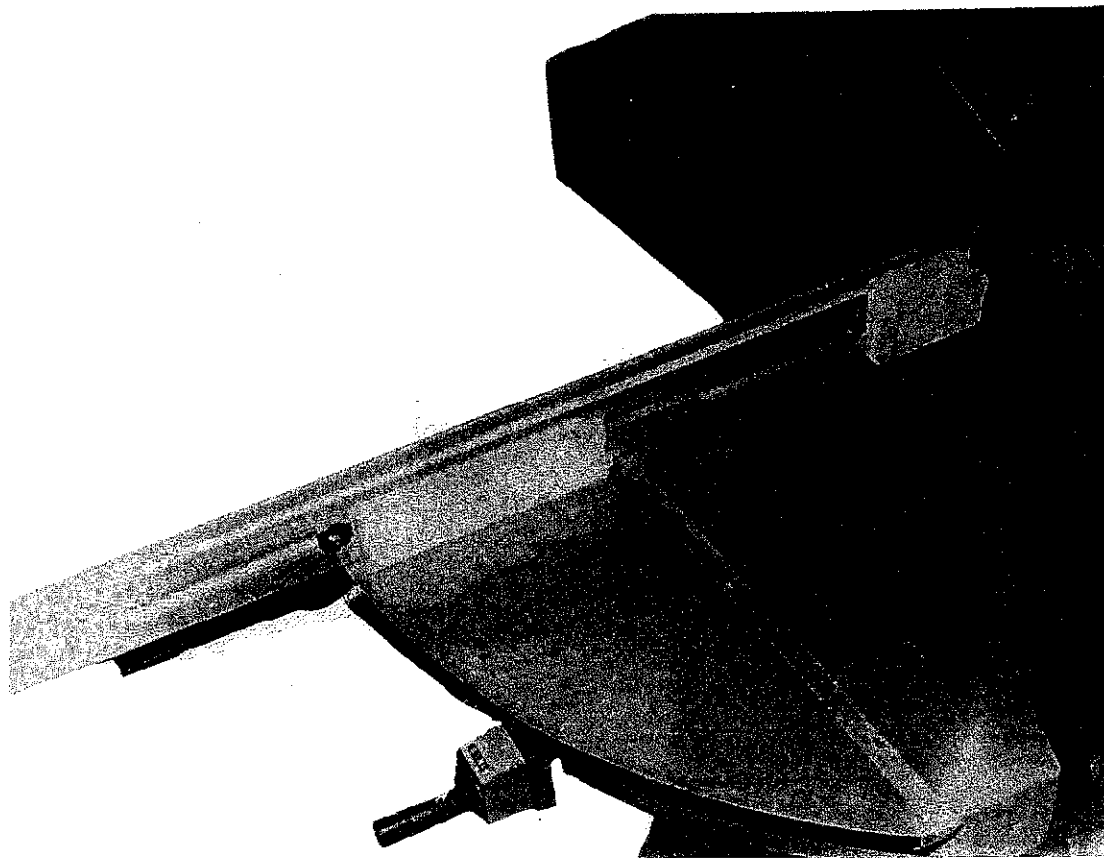


FIG.14

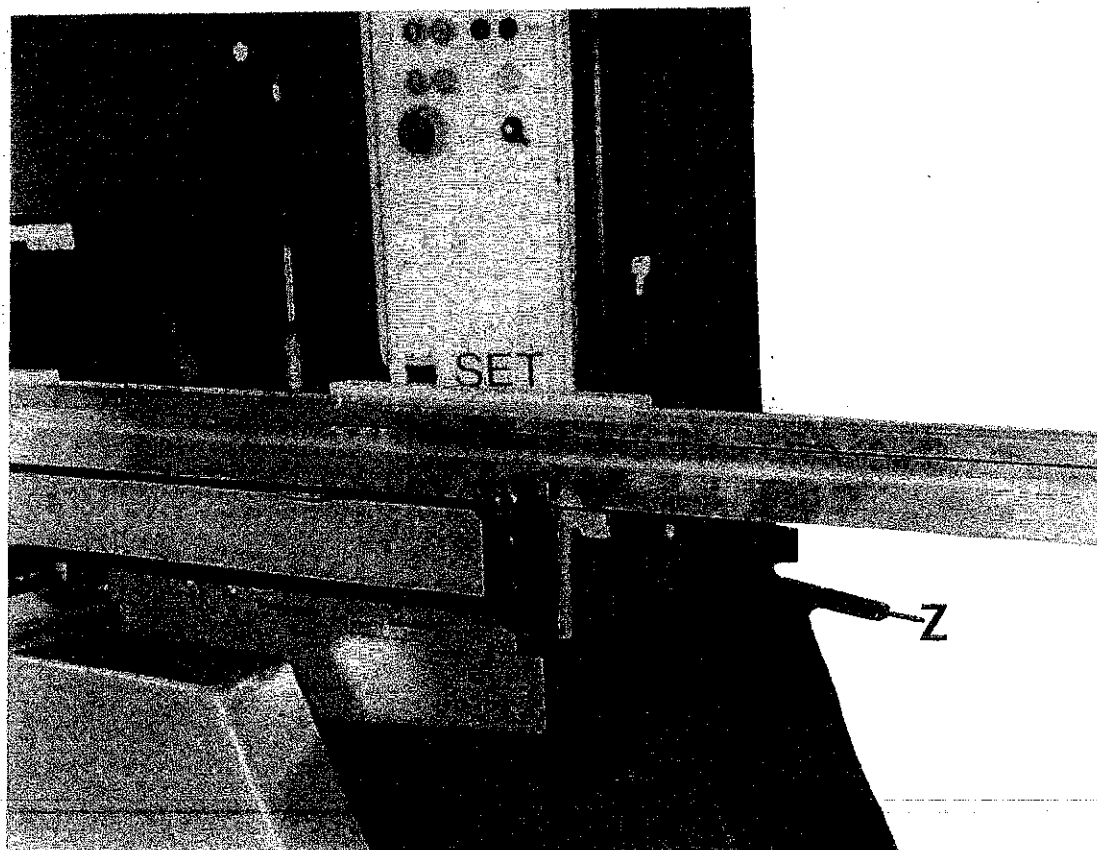


FIG.15

5.6 Front End Stop Positioning

A front end stop 'R' FIG.10 is provided to position material in relationship to the tenon heads to produce the correct length of tenon.

The length of tenon is indicated on the scale 'S'. The front end stop can be locked in position by locking handle 'T'. The length indicated on the scale is the length of tenon relative to the top tenon head when producing square shouldered tenons.

The front end stop should be positioned relative to the cut-off saw (when fitted) to ensure accurate sizing of tenons length. Should pre-cut lengths of timber be used, the front end stop can be set to produce the correct length of tenon on both ends of the material without using the cut-off saw.

The setting of the front end stop should be entered on the "Records Card" FIG.23, in the appropriate box for future reference to enable the job to be repeated at any time.

Note: Front end stop 'R' FIG.10 should be positioned as FIG.11 when using turnover shoulder stop.

5.7 Turnover Shoulder Stop Setting

The turnover shoulder stop is fitted to the fence at the front of the table. It is locked in position of the fence by lever 'U', FIG.12. The height of the stop finger above the table is locked in position by handwheel 'V' FIG.13.

The inner graduated section of the fence is adjustable to facilitate accurate setting of the stop relative to the cutters. To set graduated inner section, take measurement over shoulders on component and adjust scale until correct measurement is shown on turnover stop pointer. The graduated section is locked in position by handwheels 'W', FIG.13. For lengths longer than the fence section, the turnover stop can be positioned on sliding fence extension 'X' FIG.13 positioned to required length, and locked in position with lever 'U' FIG.12.

5.8 Backing Piece Fitting

Two adjustable backing pieces are supplied with the machine. They are locked to the fence by handwheels. These are quickly changed by loosening handwheels and lift from fence section.

NOTE: Recommended thickness of timber pieces 20-25mm.

Additional shoes are available (at extra cost) to enable different shaped backing pieces to be quickly changed to suit the tenon being produced.

Reference numbers can be given to the backing shoes and entered on the "Record Card" FIG.23, in the appropriate box for future reference to enable the job to be repeated at any time.

5.9 Mitre Fence

The mitre fence scale 'B' FIG.14 is incorporated in the table and used in conjunction with the fence 'A'. For required angle loosen locking handle 'Z' in FIG.15, move fence 'A' FIG.16 to desired position, using scale 'B' on table. Relock locking handle 'Z', FIG.15.

5.10 Electrical Controls

The control panel is shown in FIG.17. When isolator which is situated on side of control panel, is fitted, ensure it is the 'on' position before operating the machine.

Light 'A' indicates that the power supply is to the machine.

Head Controls:-

The top tenon head is controlled by stop and start buttons 'B' and 'C', FIG.17.

The bottom tenon head is controlled by stop and start buttons 'D' and 'E', FIG.17.

The cut-off saw head (when fitted) is controlled by stop and start buttons 'F' and 'G', FIG.17.

Feed Controls:-

The feed automatic cycle is controlled by start button 'H', FIG.17, in conjunction with variable traverse switch "J", FIG. 17.

For ease of tool changing and setting up, inch forward and inch reverse button 'K' and 'L', FIG.17, can be provided. The traverse will operate, in selected directions, as long as the button is depressed.

An emergency stop button 'M', FIG.17, is situated on the control panel. Depression of the emergency stop button shuts down all electrics. The emergency stop button stays in the off position until released by turning button.

5.11 Variable Speed Traverse Control

For variable control of traverse, select option 1 or 2 on variable traverse switch 'J' FIG.17. Loosen locking handle 'N' FIG.18 (situated at rear of machine and move pivot plate in conjunction with variable speed plate 'P' to required feed speed.

NOTE: When Option 1 is selected on variable traverse switch, speeds on variable speed plate should be used between 1 to 4 metres/min. (On return movement, feed speed is doubled).

IMPORTANT: Adjustment of variable speed drive should only take place when drive is running, never when it is stationary.

5.12 Adjustable Stops

Two adjustable stops 'R' FIG.19 are fitted at either end of rail and are positioned according to length of traverse required.

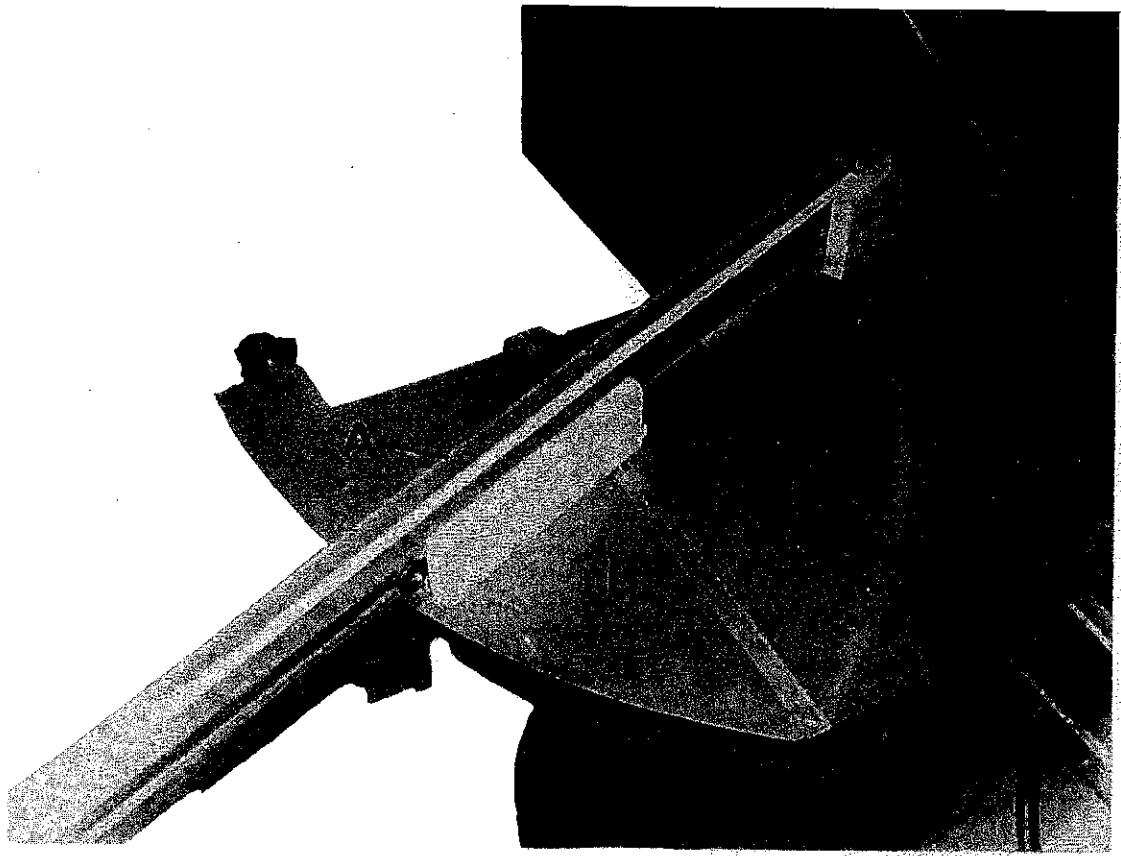


FIG.16

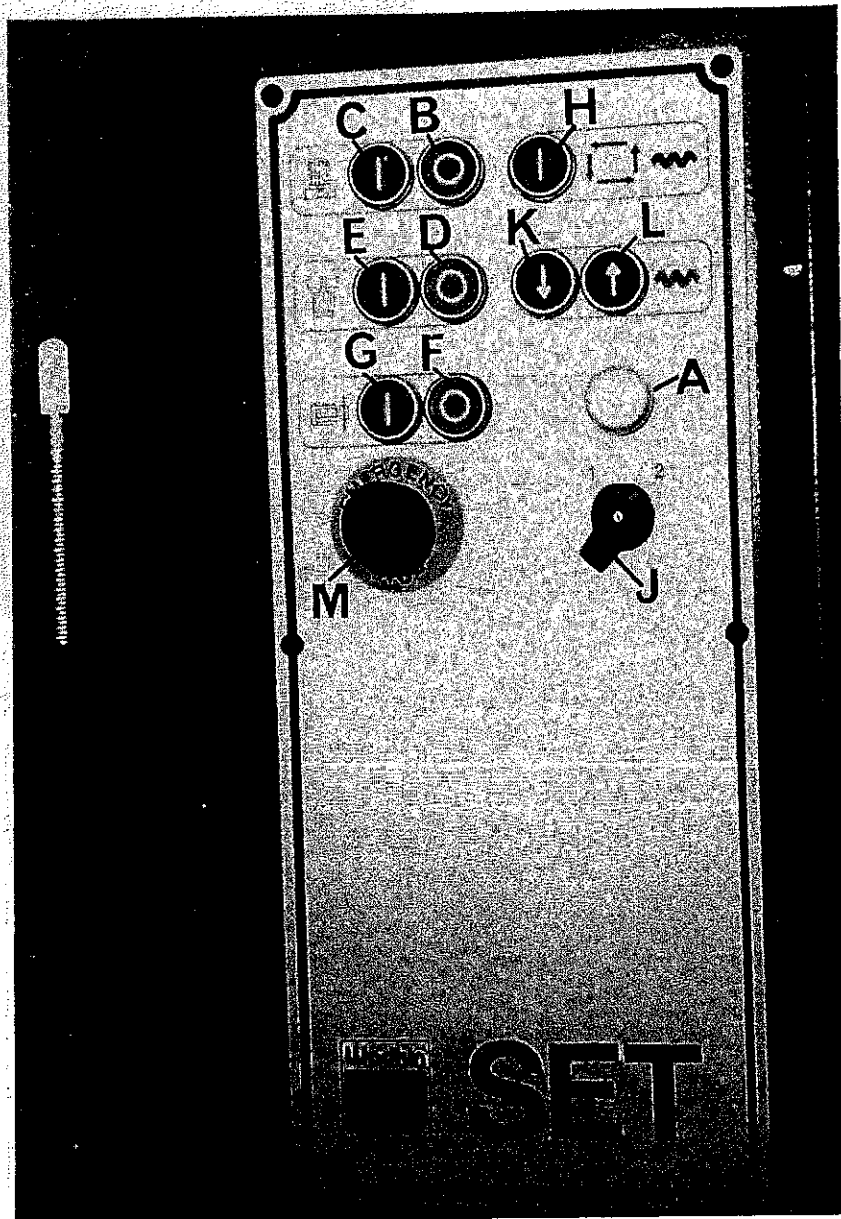


FIG.17

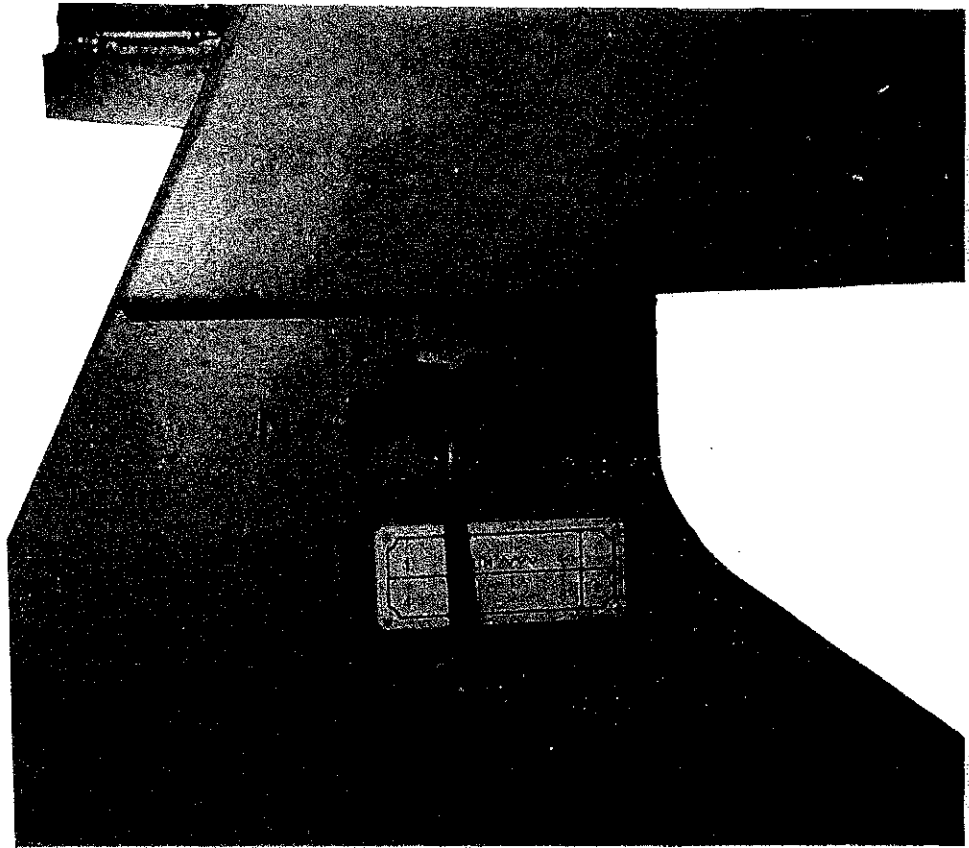


FIG.18

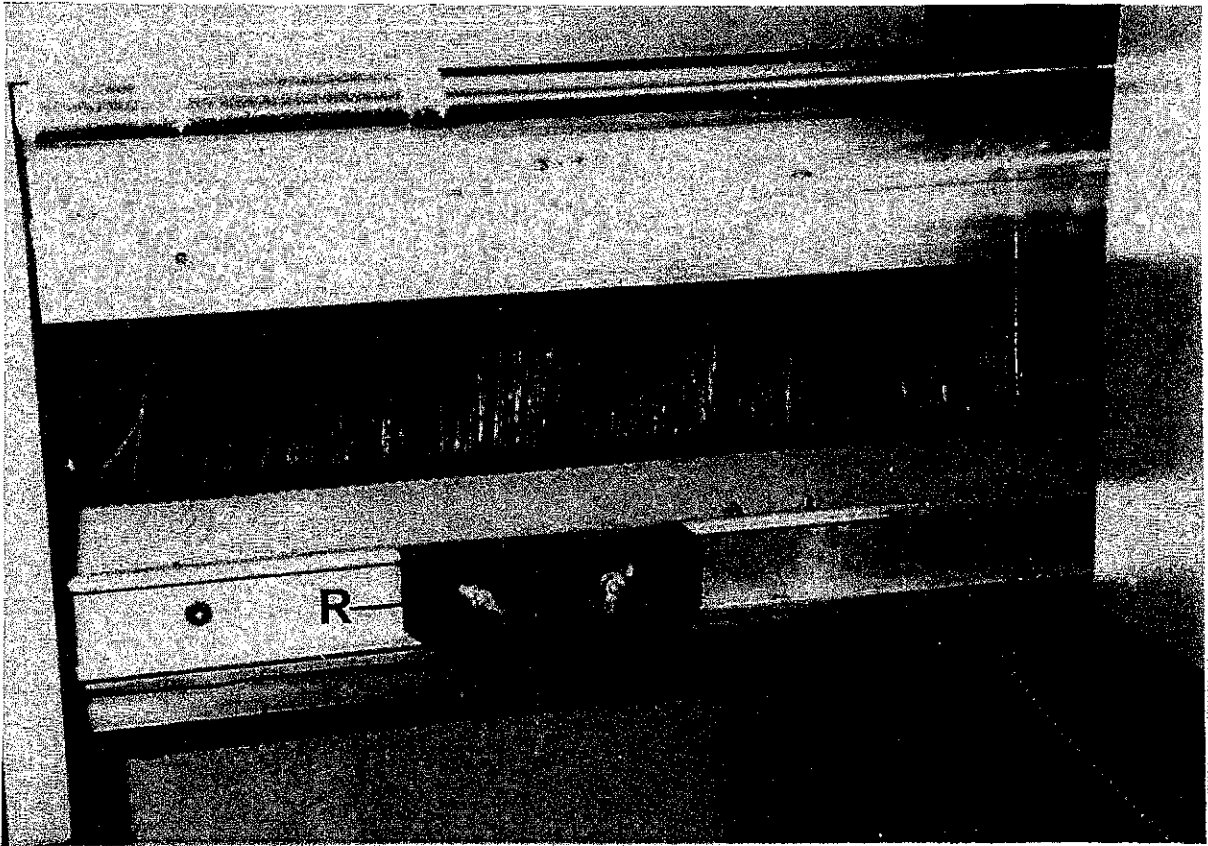


FIG.19

6.0 USE OF MACHINE

6.1 Instructions to set Size of Tenon

To set machine for a selected tenon size, refer to section 5.0.

Special attention should be paid to sections 5.1, 5.2, 5.3 and 5.4.

When job completed the sizes should be recorded on "Record Card" supplied with machine, as shown in FIG.23. The job can then be repeated at a later date using the recorded settings.

6.2 Instructions to fit Scribing Cutter Cartridges

The scribing cutters are fitted to easily removed cartridges which are held in the main tenon blocks by screws 'A', FIG.21.

To remove scribing cutter cartridges the following procedure should be followed:-

- a) Traverse head unit to cut-out in guard as shown in FIG.21.
- b) Isolate machine electrically.
- c) Slide front beam cover to gain access to the tenon cutterblocks.
- d) Loosen cartridge locking screws 'A', FIG.21.

To refit scribing cutter cartridges, the above procedure should be reversed, taking care to ensure cartridge stop washer is located against tenon cutterblock body and cartridge is seated correctly. See FIG.24.

6.3 Instructions to Fit Cut-Off Saw (when fitted)

To fit or change cut-off saw, proceed as follows:-

- a) Traverse head unit to maximum forward position.
- b) Isolate machine electrically.
- c) Lift top hood to gain access to cut-off saw.
- d) Slide front beam cover to gain access to cut-off saw.
- e) Place toggle bar in rear flange and use box spanner to remove nut as shown in FIG.22.

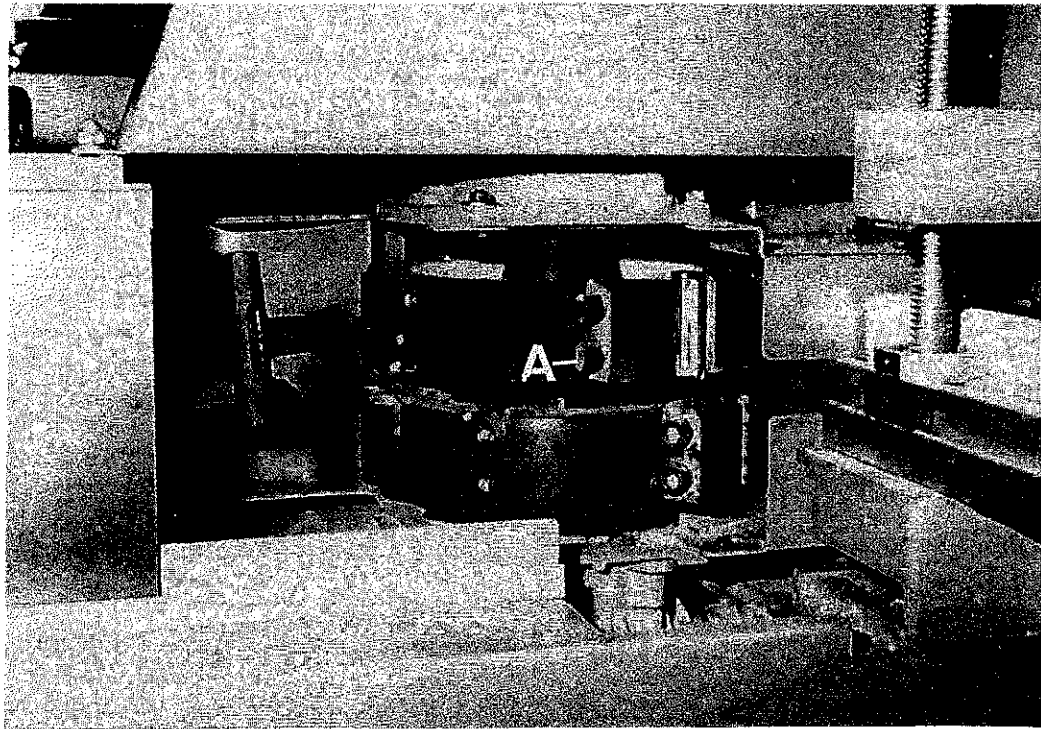


FIG. 21

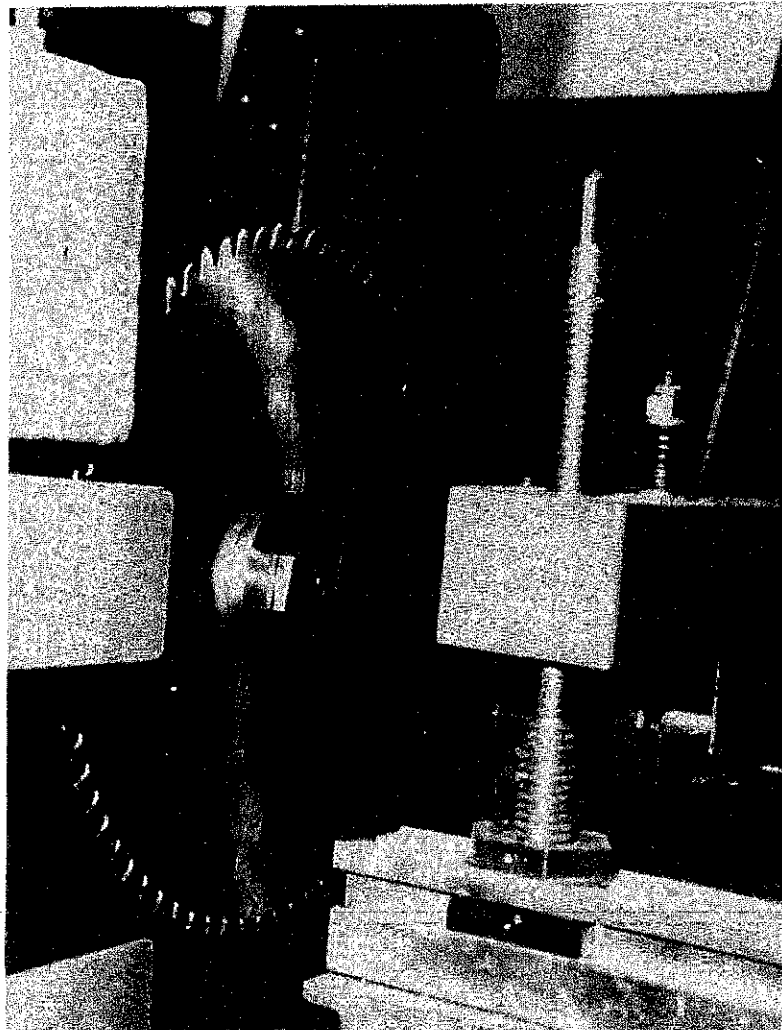


FIG. 22


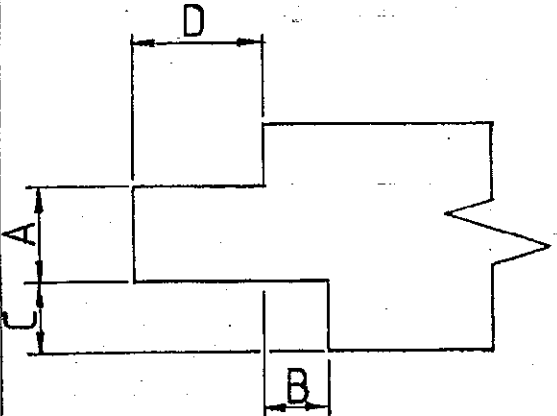
JOB No	SET RECORD CARD					
	<table border="1" style="width: 100%; height: 150px;"> <tr> <th style="width: 50%;">SCRIBE</th> <th style="width: 50%;">REFERENCE</th> </tr> <tr> <td style="height: 140px;"></td> <td style="height: 140px;"></td> </tr> </table>	SCRIBE	REFERENCE			
SCRIBE	REFERENCE					
SETTING		DIMENSIONS				
READOUT A	READOUT B	READOUT C				
READOUT D	FRONT -END STOP	BACKING PIECE				

FIG. 23

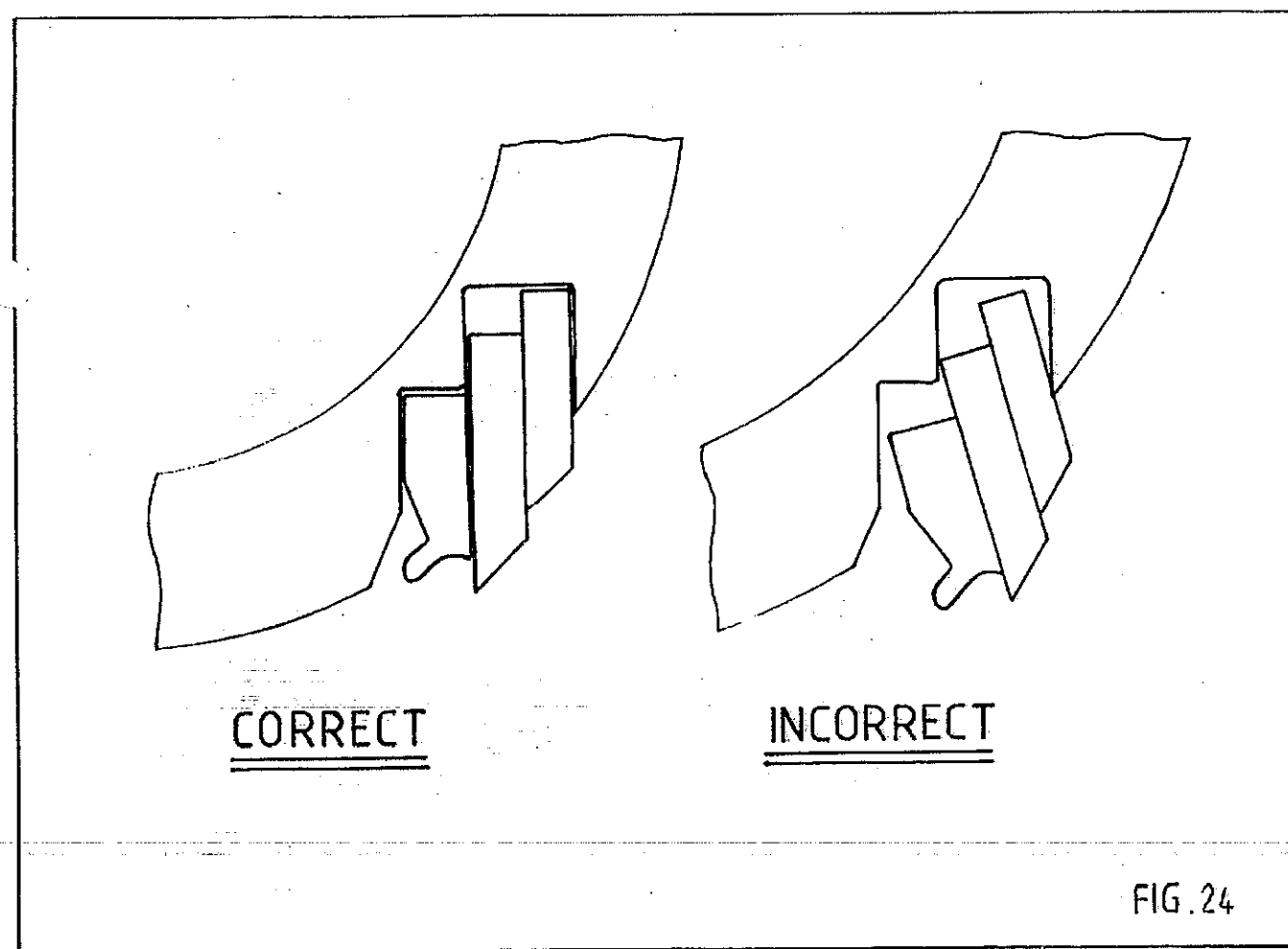


FIG. 24

7.0 MAINTENANCE

7.1 Lubrication

The majority of machine working parts are designed to require no lubrication.

The following should be done on a weekly basis:

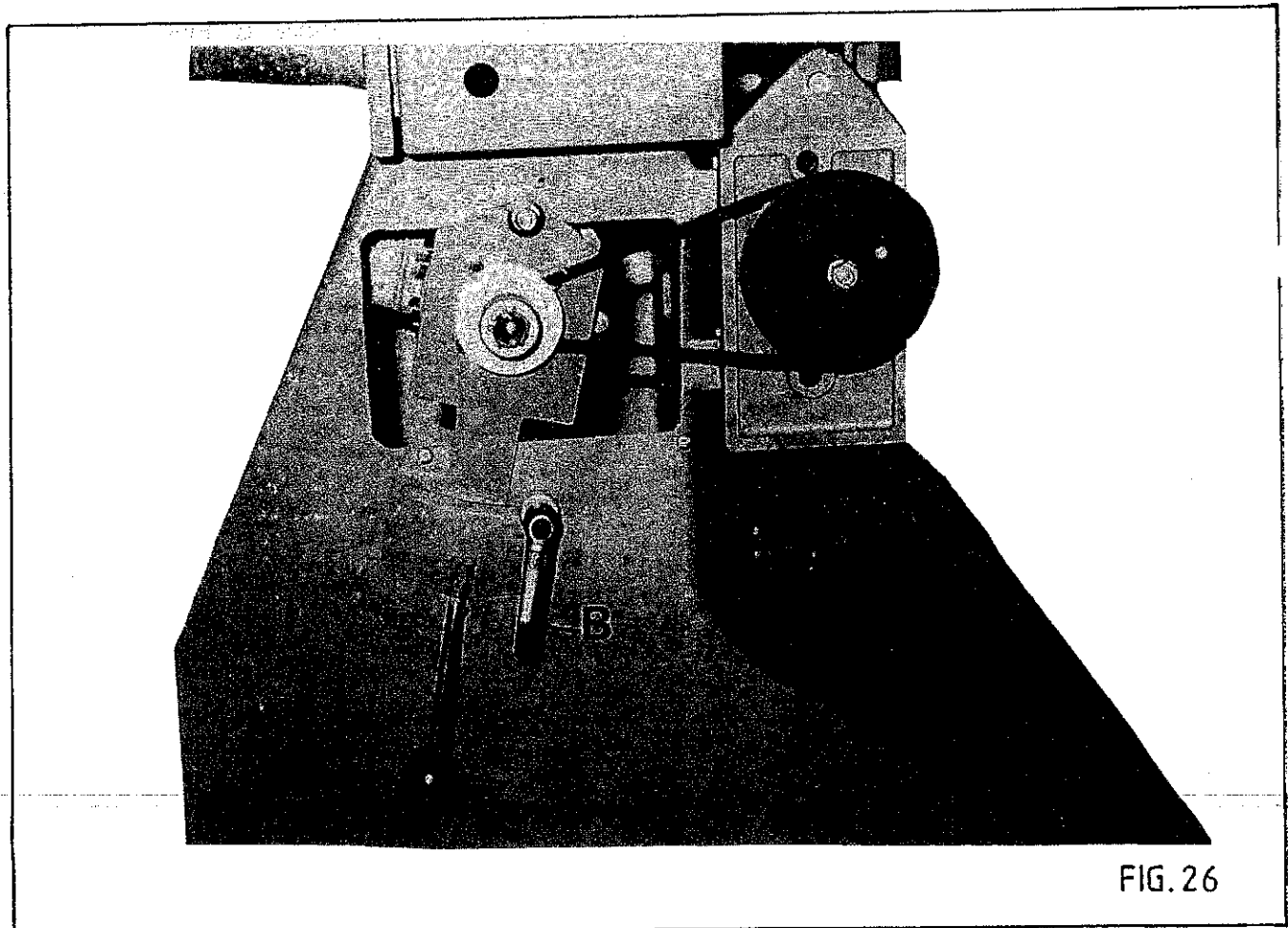
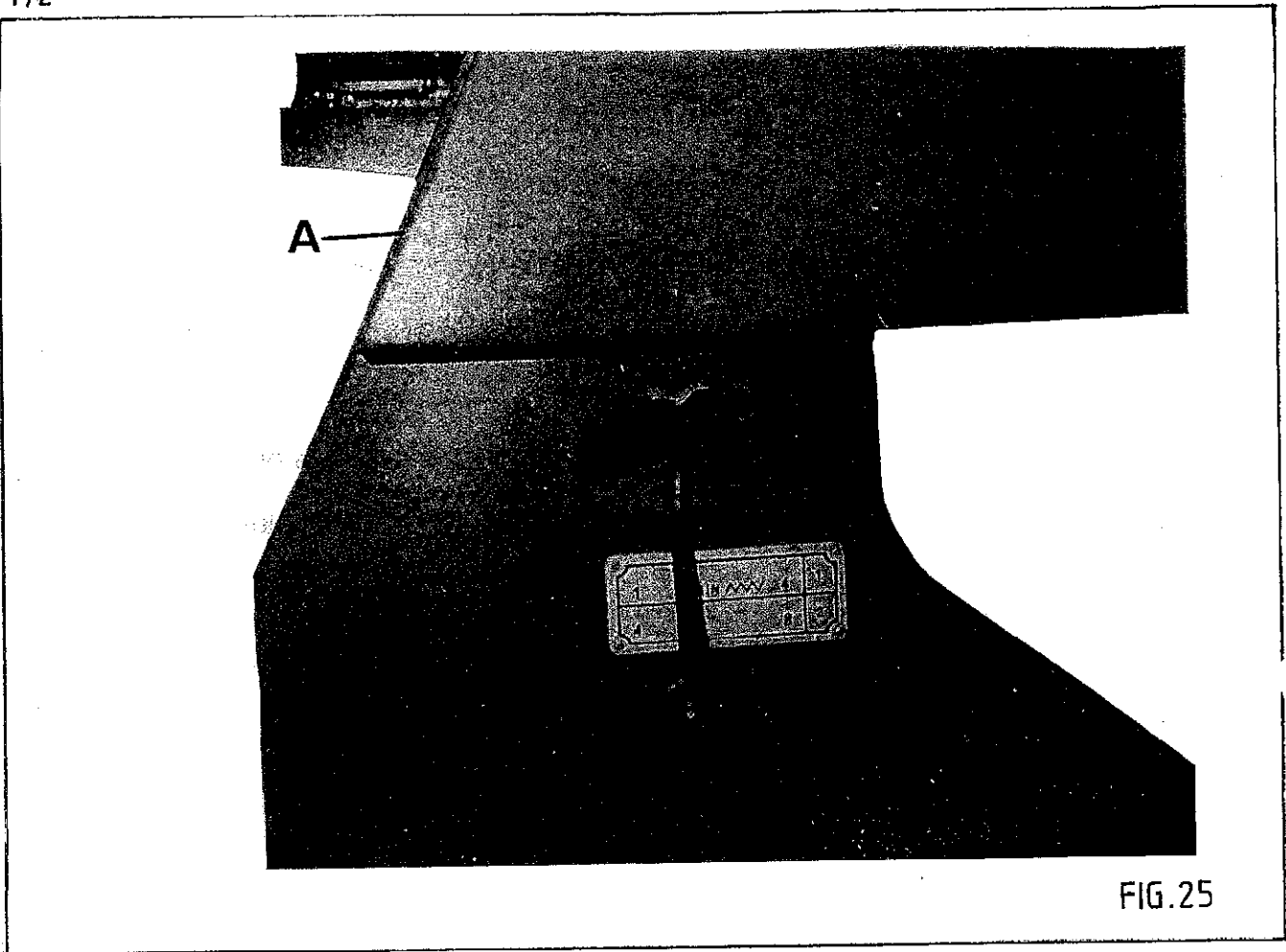
- a) Oil slideways, vertical and horizontal screw on table.
- b) 2 shots of grease to ball screw through 2 grease nipples on carriage.
- c) 2 shots of grease to carriage bearings through grease nipples in top face of carriage.

See page 7/3 for list of approved lubricants.

7.2 Belt Change on Variable Speed Traverse

To change belt, proceed as follows:-

- a) Traverse head to forward position.
- b) Isolate machine electrically.
- c) Remove drive belt cover 'A' FIG.25 at rear of machine.
- d) Release tension on pulleys by loosening locking handle 'B' FIG.26 and moving handle 'C'.
- e) Position new belt over pulleys and tension belt by moving handle 'C' and lock in position by locking handle 'B'.
- f) Replace drive belt cover.



APPROVED LUBRICANTS						
Application	Castrol	B.P.	Shell	Esso	Texaco	Century
Worm Boxes	Alpha SP220	Energol XP220	Omala 220	Spartan EP220	Meropa 220	F76
General Lubrication	Magna 68	Maccurat 68	Tonna T68	Febis K68	Way Lube 68	WLC
Pneumatic Lubricators	Hyspin AWS32	Energol HL32	Tellus 37	Nuto H32	Rando Oil HD32	AF32
Grease	Spheerol AP3	Energrease L53	Alvania R3	Beacon 3	Multifak EP3	Lupas A3
Brake Cables	Brake Cable Grease	Energrease L21M	Alvania R3	Multi-Purpose Grease		Molycent MP

8.0 SPARES

8.1 Instructions When Ordering Spare/Replacement Parts

The undermentioned information should be given with all orders requesting spare/replacement parts.

- a) Machine type.
- b) Machine serial number.
- c) If no manual available, give as full a description as possible of the required part, including location within the machine.
- d) Order number and full company name and address.
- e) Company account number, with **Wadkin**, if known.
- f) All telephone orders must be followed by an official order, clearly marked "Confirmation Order".

NOTE: The company operate a 'Minimum Order Charge' on all spare/replacement part orders.

9.0 TOOLING

9.1 Instructions for Square and Scribing Cartridges

- a) Assemble cutterknife as showing in FIG.27.

NOTE: Stop washer "A" when fixed to base of cartridge assembly is for bottom head. When fixed to top of cartridge assembly, is for top head.

- b) Locate cutter cartridge assembly in setting stand (noting that top head cartridge locates in lower section of setting stand and bottom head cartridge into top section of setting stand). See FIG.28.
- c) Ensure that cartridge locates against magnet face on left hand side of setting stand and that washer "A" locates against the countersunk screw "C" at end of setting stand.

9.2 Instruction for Square Cutters

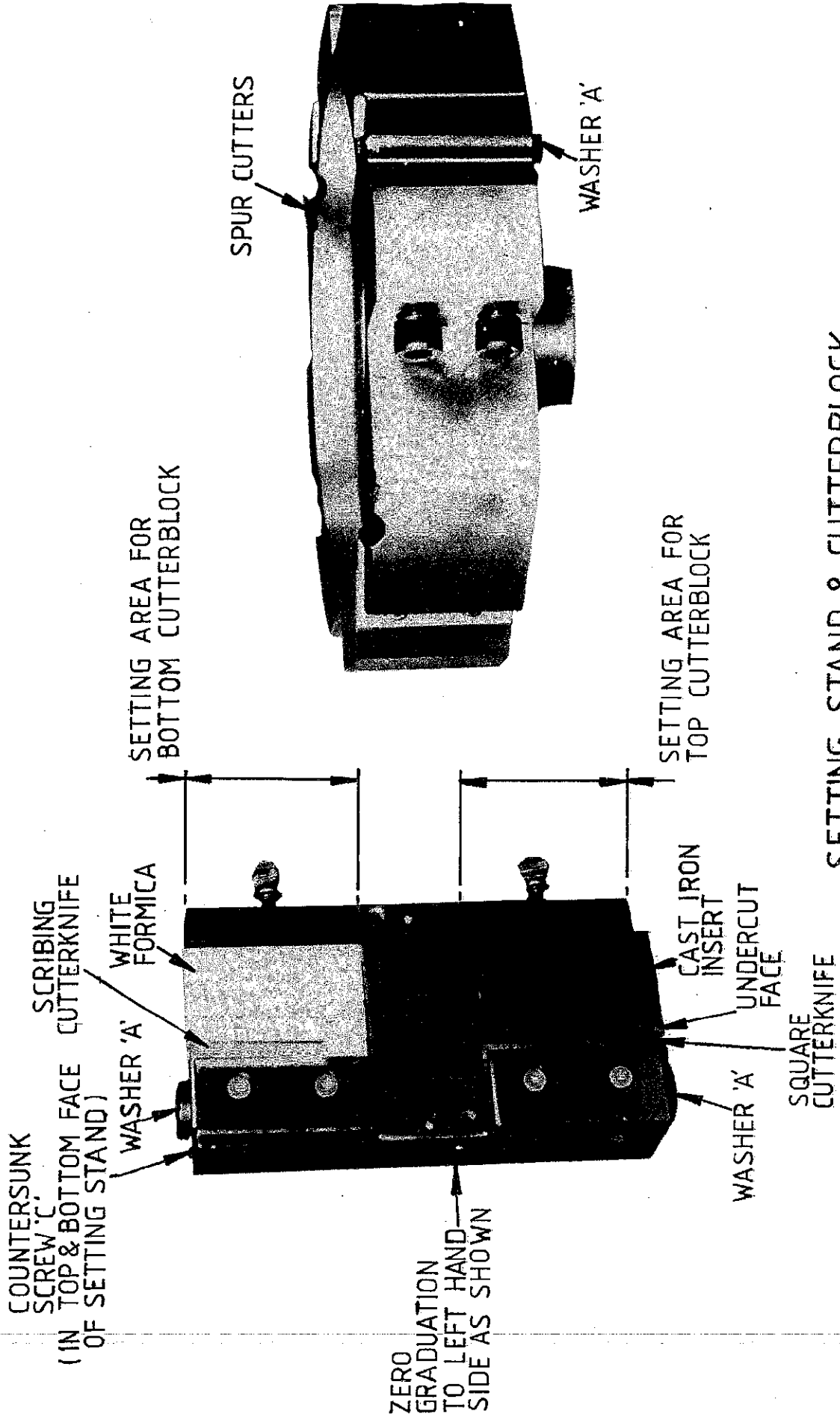
- a) Locate cast iron insert into setting stand ensuring that undercut lip is facing zero graduation. Position cutter knife against undercut face FIG.28 for correct projection.
- b) Securely lock cutter, wedge and backing piece.
- c) Locate remaining cartridges into setting stand and position cutter knives correctly. Securely lock the assembly.

9.3 Instructions for Scribing Cutters

- a) Locate white formica insert into setting stand.
- b) Zero graduation on the brass scale represents the cutting circle diameter. Adjust cutter to give the correct projection keeping cutter knife against brass scale.
- c) Securely lock wedge and back piece. Draw around profile on cutter on white formica board in cutterstand.
- d) Locate remaining cartridges into setting stand and position cutterknife against the drawn profile. Securely lock the assembly.



9.4 Instructions for Square and Scribing Cartridges

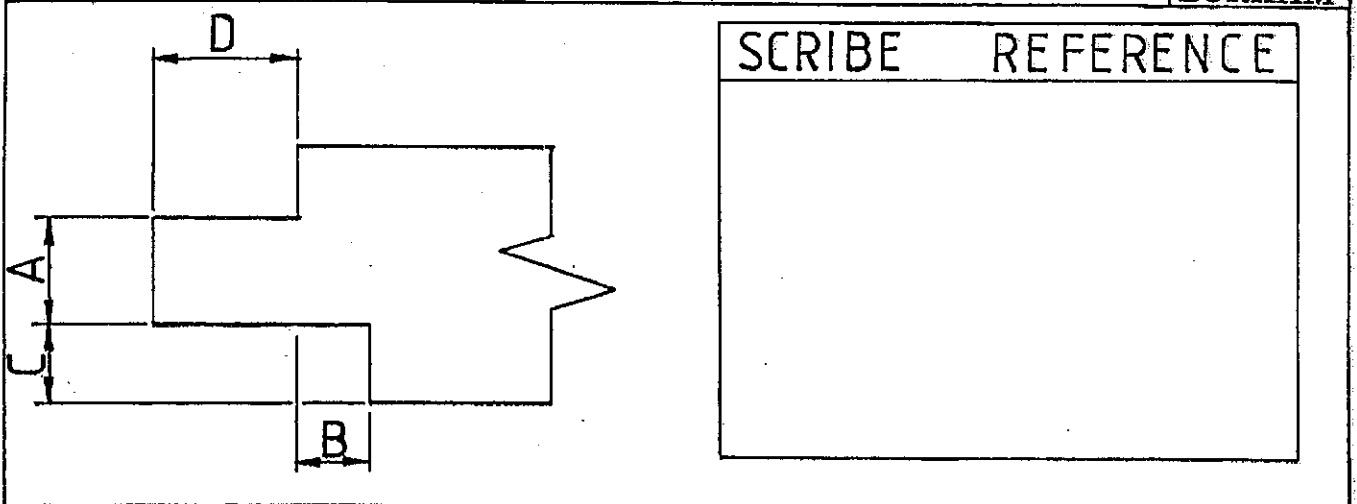
- a) Fit cartridges to cutterblock, ensuring that stop washer "A" locates against edge of cutterblock.
- b) When cartridges are correctly fitted in cutterblock, then the edge of the cutter knife should be the same height as the spur cutters. Should adjustment be required, then turn countersunk screw "C" as necessary and reset cutter knife.



SETTING STAND & CUTTERBLOCK



FIG. 28

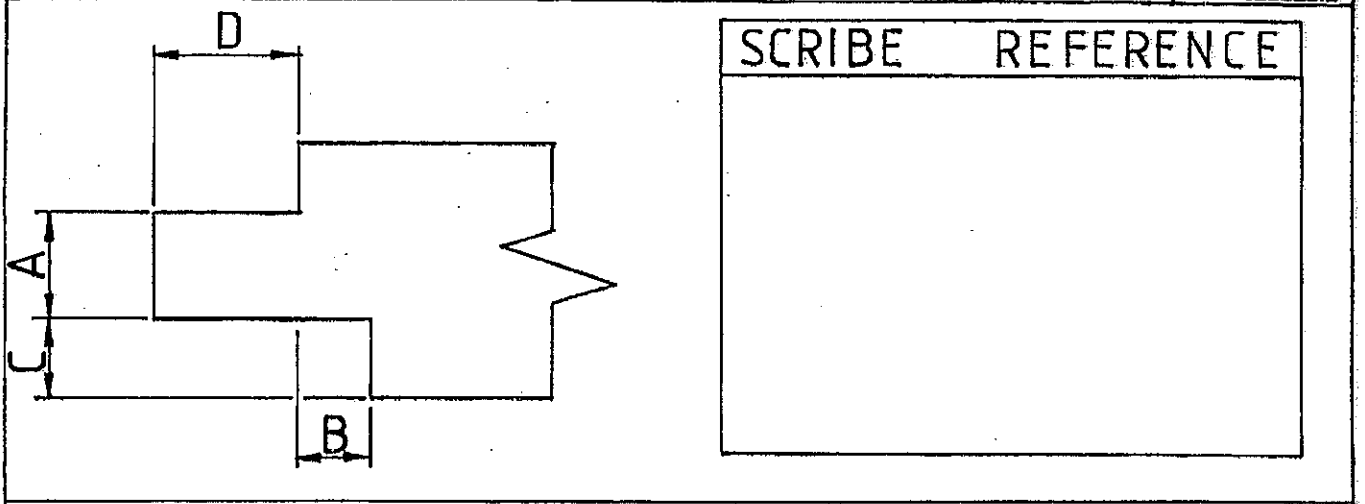
JOB No	SET RECORD CARD	 Wadkin  DURHAM



SCRIBE REFERENCE



SETTING			DIMENSIONS		
READOUT A	READOUT B	READOUT C	READOUT D	FRONT -END STOP	BACKING PIECE

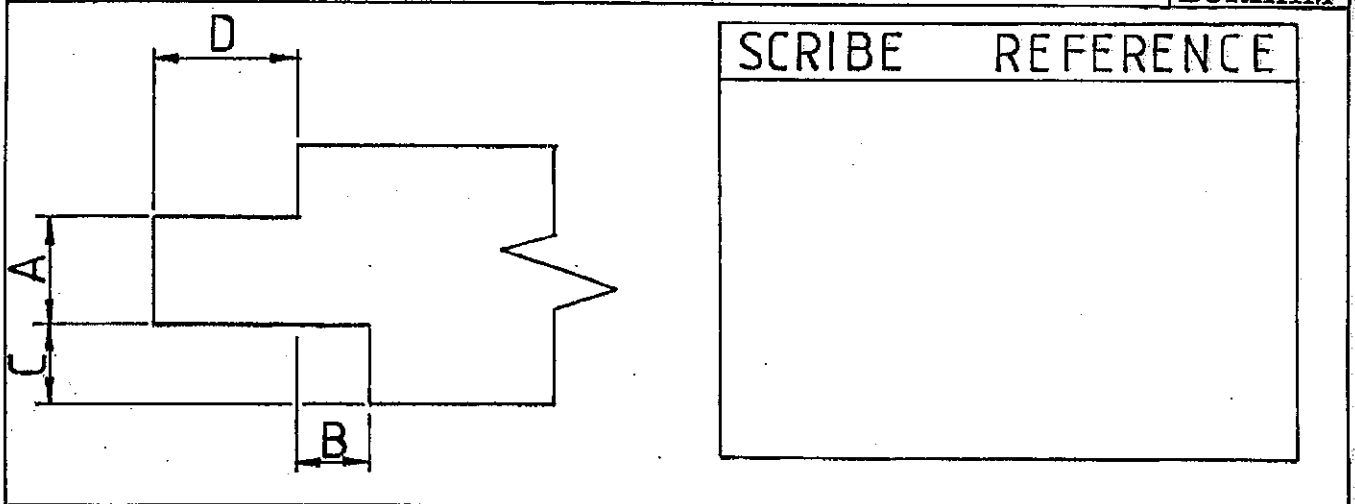
JOB No	SET RECORD CARD	 Wadkin  DURHAM



SCRIBE REFERENCE



SETTING			DIMENSIONS		
READOUT A	READOUT B	READOUT C	READOUT D	FRONT -END STOP	BACKING PIECE

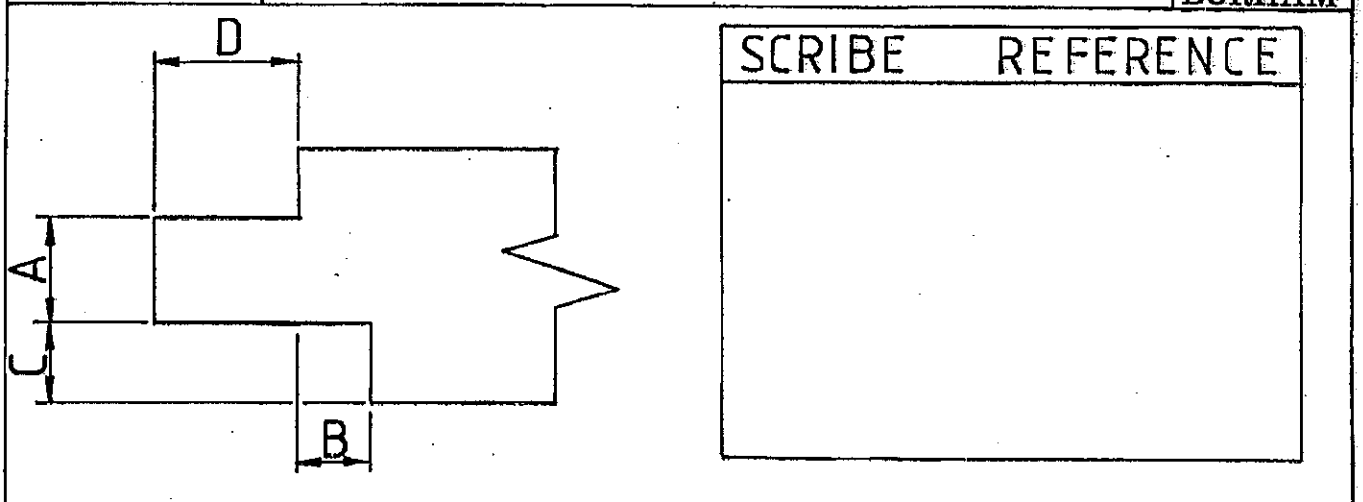
JOB No	SET RECORD CARD	 Wadkin  DURHAM



SCRIBE REFERENCE

SETTING			DIMENSIONS		
READOUT A	READOUT B	READOUT C	READOUT D	FRONT -END STOP	BACKING PIECE

JOB No	SET RECORD CARD	 Wadkin  DURHAM

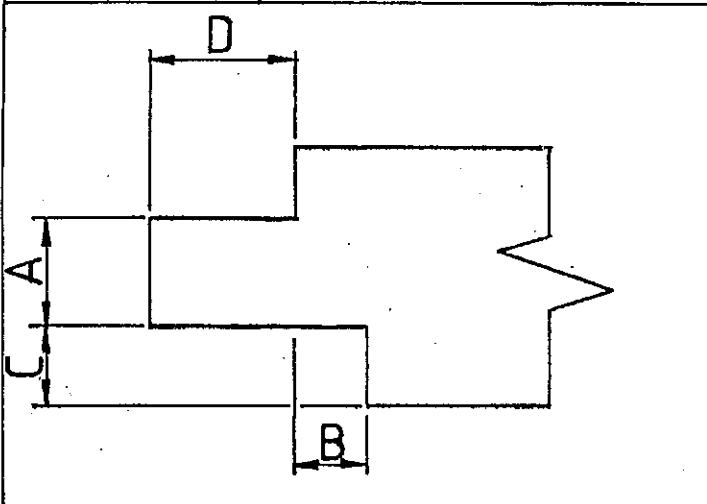


SCRIBE REFERENCE

SETTING			DIMENSIONS		
READOUT A	READOUT B	READOUT C	READOUT D	FRONT -END STOP	BACKING PIECE

JOB No

SET RECORD CARD

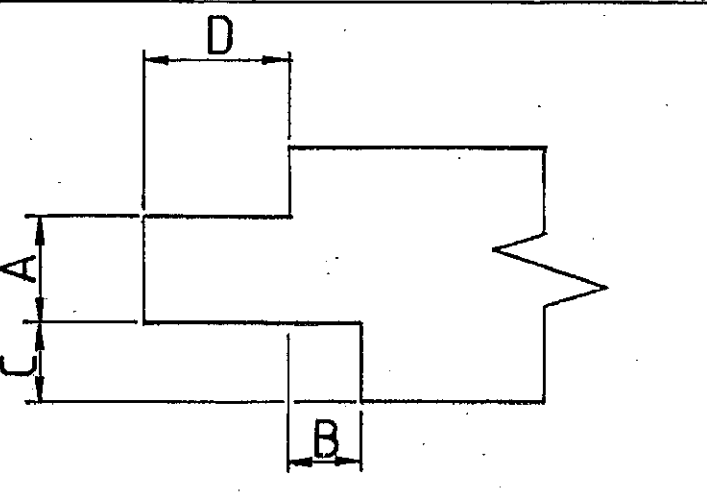


SCRIBE	REFERENCE

SETTING			DIMENSIONS		
READOUT A	READOUT B	READOUT C	READOUT D	FRONT -END STOP	BACKING PIECE

JOB No

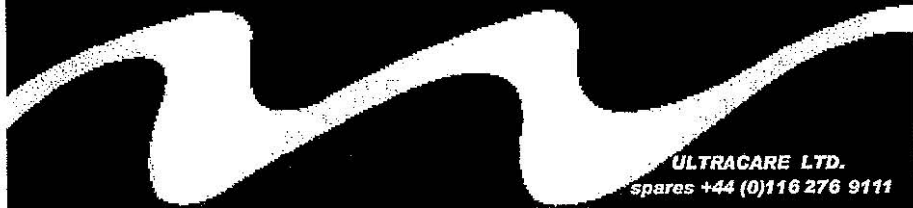
SET RECORD CARD



SCRIBE	REFERENCE

SETTING			DIMENSIONS		
READOUT A	READOUT B	READOUT C	READOUT D	FRONT -END STOP	BACKING PIECE

Wadkin



ULTRACARE LTD.
spares +44 (0)116 276 9111