

***OPERATING AND INSTRUCTION***

***MANUAL FOR***

***MEDIUM DUTY SPINDLE MOULDER***

***TYPE***

***BER 2***



T: 0116 2769111  
F: 0116 2598138

# MEDIUM DUTY SPINDLE MOULDER TYPE BER.2.

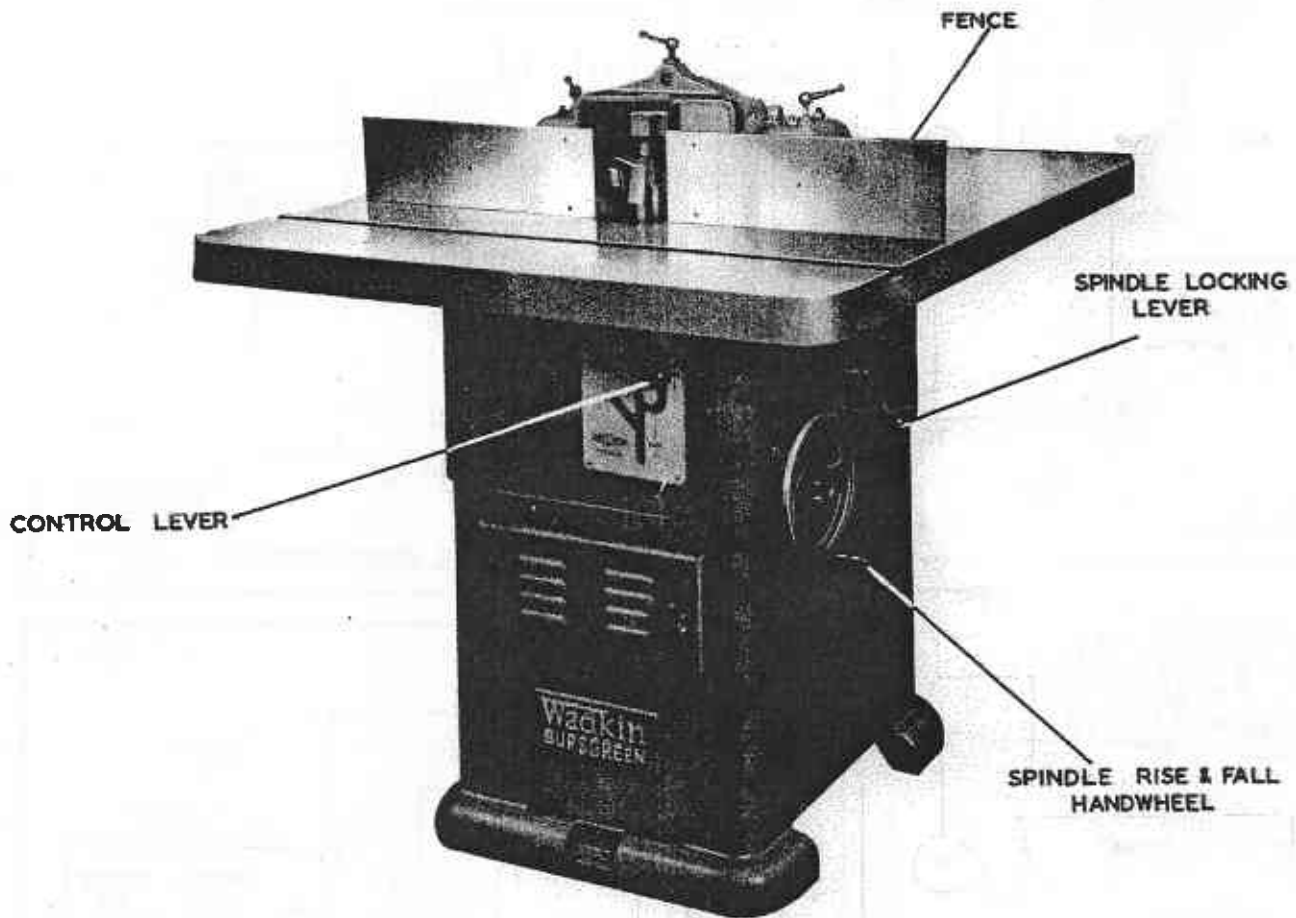

**FIG. 1.**

### SPECIFICATION

Diameter of top piece (Standard)	$1\frac{1}{4}$ "	30mm
Optional diameter of top piece	$\frac{3}{4}$ ", 1"	20mm, 25mm
Size of table	30" x 36"	760 x 915mm
Speed of spindle		4, 500 and 7, 000 rpm
Rise and fall of spindle	3"	75mm
Table height	$33\frac{1}{2}$ "	850mm
Two circular table plates give openings of	$6.5/8$ ", $3\frac{1}{2}$ ", $2\frac{3}{4}$ "	170, 90, 70mm
Size of fence plates	$14$ " x $4\frac{1}{2}$ "	355 x 115mm
H. P. of motor (3 phase)		3 (Standard)
		4 (Optional extra)
H. P. of motor (1 phase)		3
Speed of motor		3, 000 rpm
Floor space	30" x 36"	760 x 915mm
Approx. nett weight	510 lb	230 kg
Approx. gross weight	672 lb	305 kg
Approx. shipping dimensions	30.8 cu. ft.	.87m <sup>3</sup>

## INSTALLATION

Remove protective coating from bright parts by applying a cloth soaked in paraffin, turpentine or other solvent.

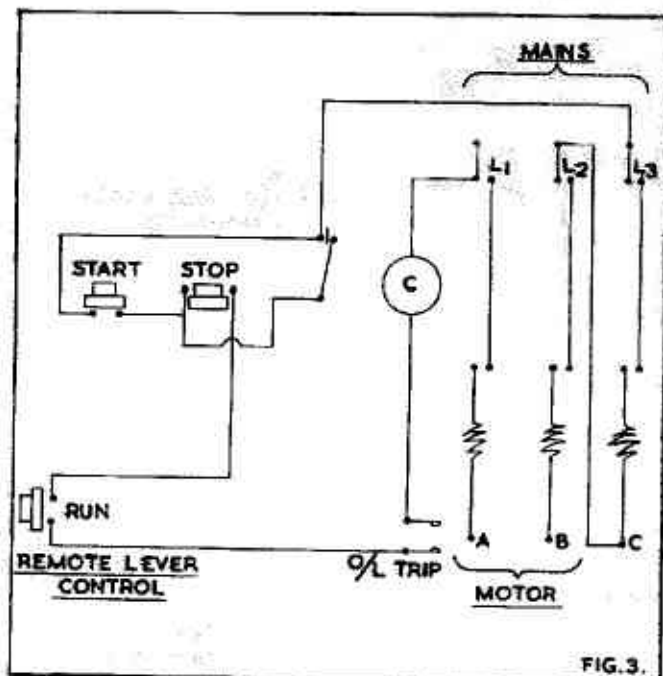
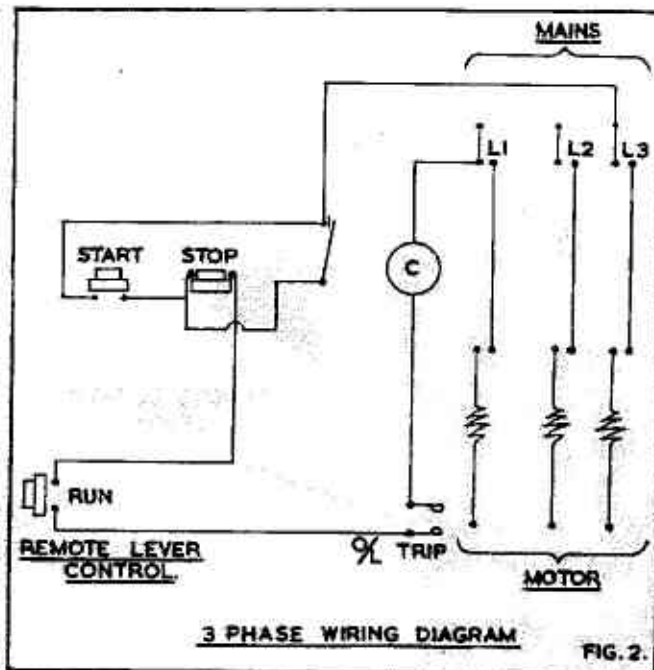

### WIRING DETAILS

The motor and control gear have been wired in before despatch, all that is required is to connect the power supply to the starter or isolator when fitted.

Points to note when connecting to power supply :-

1. Check that the voltage, phase and frequency correspond to those on the motor plate, also the correct coils and heaters are fitted to the starter.
2. It is important that the correct size of cable is used to give the correct voltage at the starter. Too light a cable will give a voltage drop at the starter and may damage the motor.
3. Check the main line fuses are of the correct capacity. See list below. When an isolator is fitted, the fuses are of the correct capacity as received.

4. Connect the line leads to the appropriate terminals. See fig. 2 for 3 phase supply and fig. 3 for 1 phase supply.

5. Check all connections are sound.

6. Check the rotation of the motor for the correct direction. If this is incorrect, reverse any two of the line lead connections for 3 phase supply.

Voltage	Phase	H. P.	S. W. G. Tinned Copper Wire	Amps
220	3	3	21	29
380/420	3	3	23	20
550	3	3	24	17
200/220	1	3	15	78
230/250	1	3	17	65
220	3	4	19	38
380/420	3	4	22	24
550	3	4	23	20

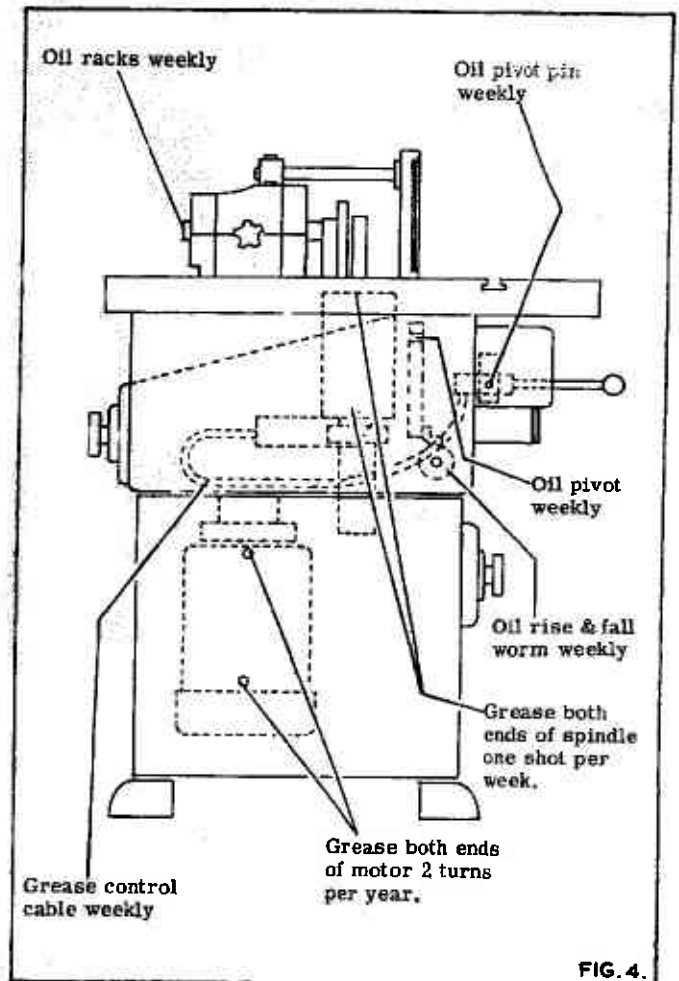

### LUBRICATION

It is advisable to keep all bright parts covered with a thin film of oil to prevent rusting.

TYPE OF OIL RECOMMENDED  
TYPE OF GREASE RECOMMENDED  
TYPE OF GREASE RECOMMENDED  
FOR BRAKE CABLE

POWER EM125  
SHELL ALVANIA 3  
CASTROLEASE  
BRAKE CABLE  
LUBRICANT

### FOUNDATION

See fig. 5 for bolt positions and clearances required. When installing the machine level the table by packing under the feet.

Foundation bolts are not supplied with the machine except by special order.

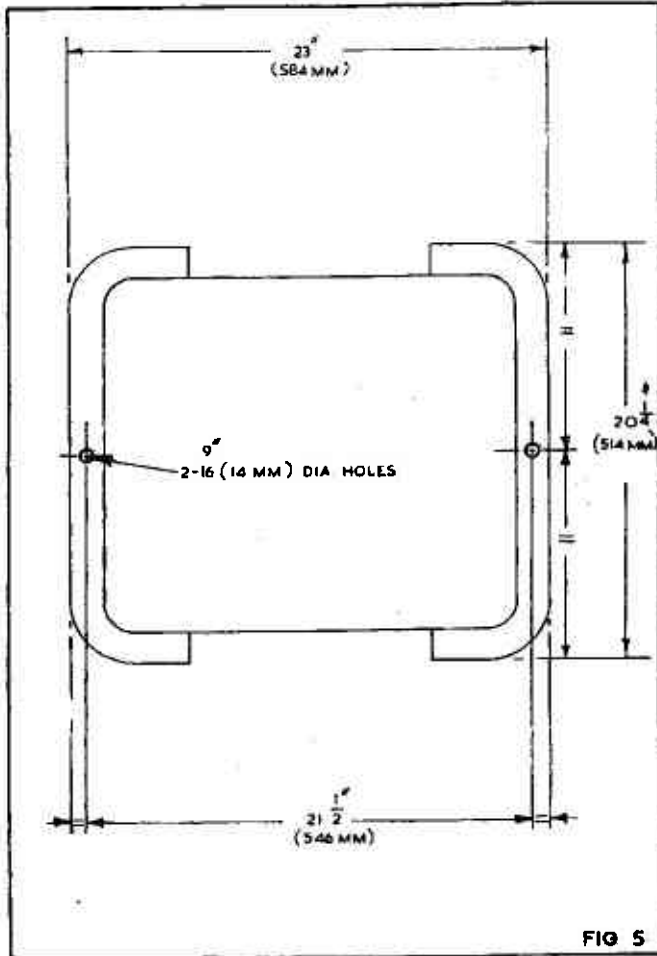

FIG 5

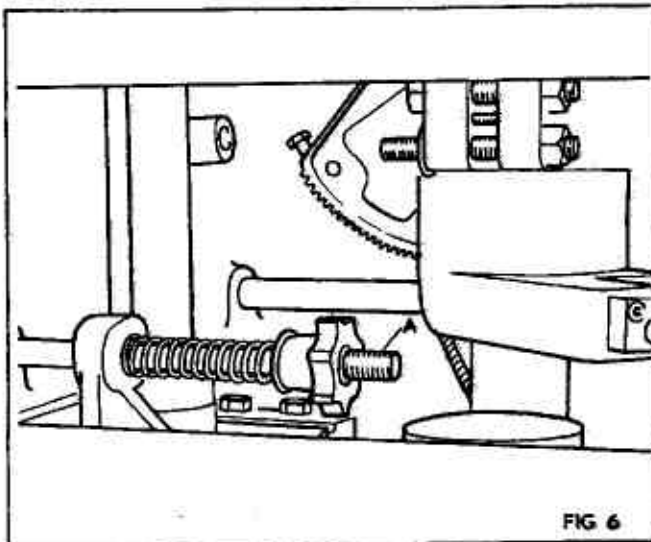

FIG 6

#### BELT TENSION

The machine is driven by an endless flat belt from a 3 H. P. motor mounted on a hinged bracket inside the base of the machine. A handwheel removes the tension on the belt for changing the speed of the machine spindle.

To change the speed the undermentioned procedure should be followed:-

1. Check the control handle is in the "free" position as described in the following section.
2. Open the door at the rear of the machine for access to the pulleys.
3. Remove the tension on the belt by unscrewing the handwheel "A" in fig. 6.
4. Select the required speed and re-tension the belt by screwing the handwheel "A".

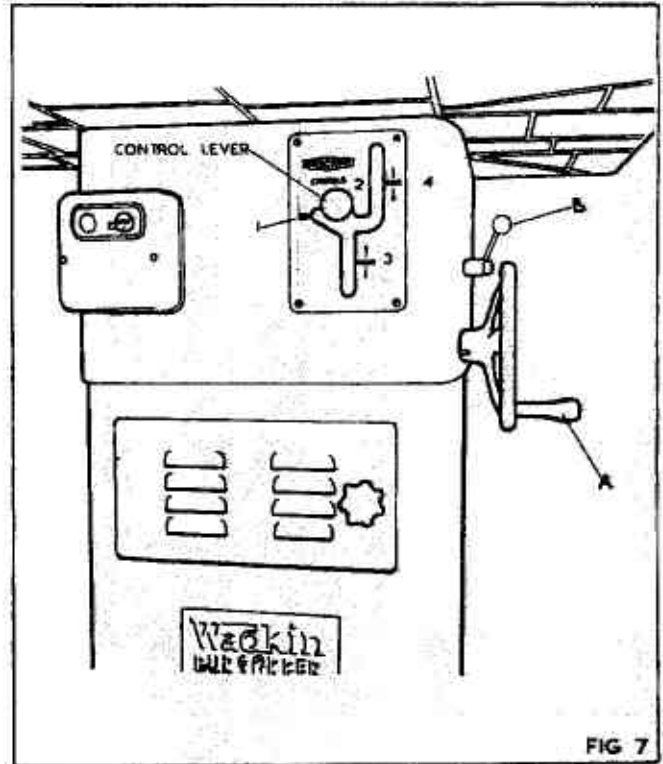

FIG 7

#### RISE AND FALL OF SPINDLE

The spindle rise and fall is by means of the handwheel "A" in fig.

The rise and fall of the spindle is obtained through a worm-wheel on a racked quadrant and has a maximum travel of 3" (76mm).

The height of the spindle can be efficiently locked in any position of its travel by means of the locking lever "B".

Whilst the rise and fall movement of the spindle provides an immediate adjustment to the cutter height, further adjustment outside the range of this can be effected by re-positioning the collars on the work spindle.

The spindle should be rotated by hand whilst raising or lowering the spindle in order to prevent excessive stretch on the belt.

#### 4. POSITION CONTROL BOX

The control box is shown in fig.

##### Position 1

This is marked "run" and is the only control lever position where the machine can be operated.

##### Position 2

This position is marked "free" when the control lever is in this position the motor is isolated and the work spindle can be rotated by hand. The control lever should be in this position at all times when the machine is not required for operation to ensure the machine cannot be started up accidentally.

This position should also be used when setting cutter equipment.

##### Position 3.

This position is marked "brake". Movement of the control lever from the "run" to this brake position automatically switches off the motor and light pressure on the lever operates a very efficient brake to the spindle.

##### Position 4.

This position is marked "lock". When the control lever is in this position the motor is isolated and the main spindle is locked to facilitate the removal of the work spindle or cutter equipment as required. The spindle may require rotating by hand to ensure the lock is fully engaged before attempting to change cutter equipment or the work spindle.

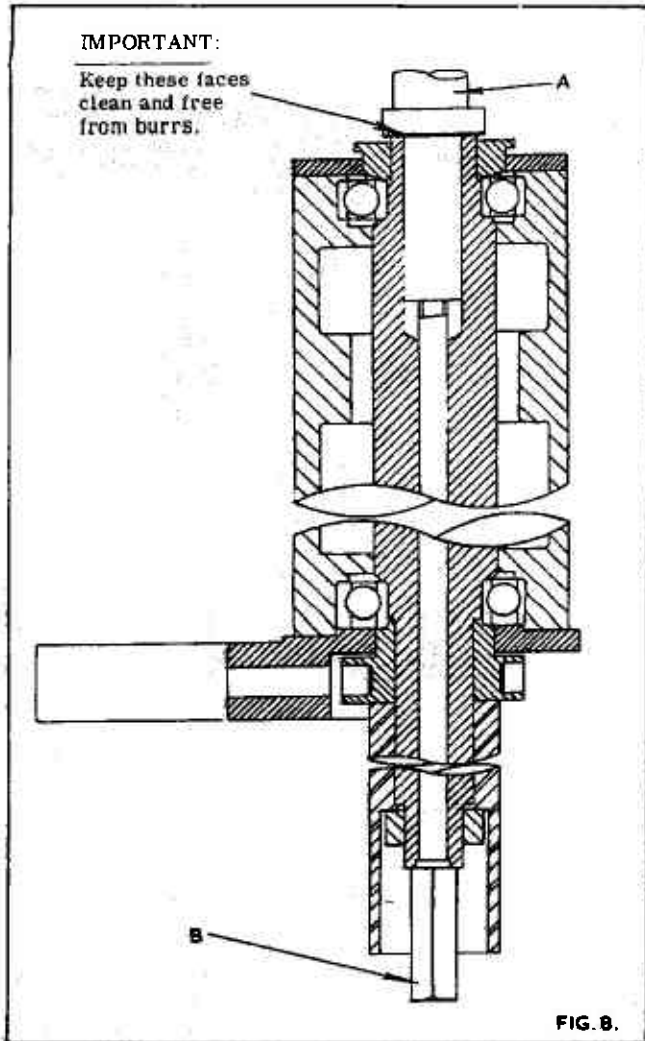

#### WORK SPINDLE INSTALLATION

Before inserting the work spindle, select which of the three table ring openings you require. The two removable rings give hole sizes of 6, 5/8", 3 1/2" and 2 1/4" dia. (170, 90 and 70mm).

To insert the work spindle the undermentioned procedure should be followed:-

1. Insert the work spindle "A" in fig. 8 into the main spindle through the hole in the table top. Great care should be taken to ensure that the work spindle and main spindle seatings are completely free from all burrs, dirt and rust. A thin film of oil should be put on the work spindle seatings before inserting. Line the peg in the work spindle with the slot in the main spindle and press spindle onto seating.

2. Open access door at the front of the machine.

3. Move control Box Lever to "lock" position as previously described.

4. Insert the spindle drawbolt "B" up the centre of the main spindle and screw into the end of the work spindle and lock with spanner provided.

Note :- Drawbolt thread is right hand.

The spindle is now ready to receive the cutter equipment as required.

To remove the work spindle the undermentioned procedure should be followed:-

1. Lock main spindle as previously described.
2. Open access door at the front of the machine.
3. Unscrew the drawbolt "B" and withdraw from the main spindle
4. The work spindle "A" can now be removed by lifting clear through the hole in the table

#### Important

Always ensure at all times that work spindle is secured, held by drawbolt before starting the machine.

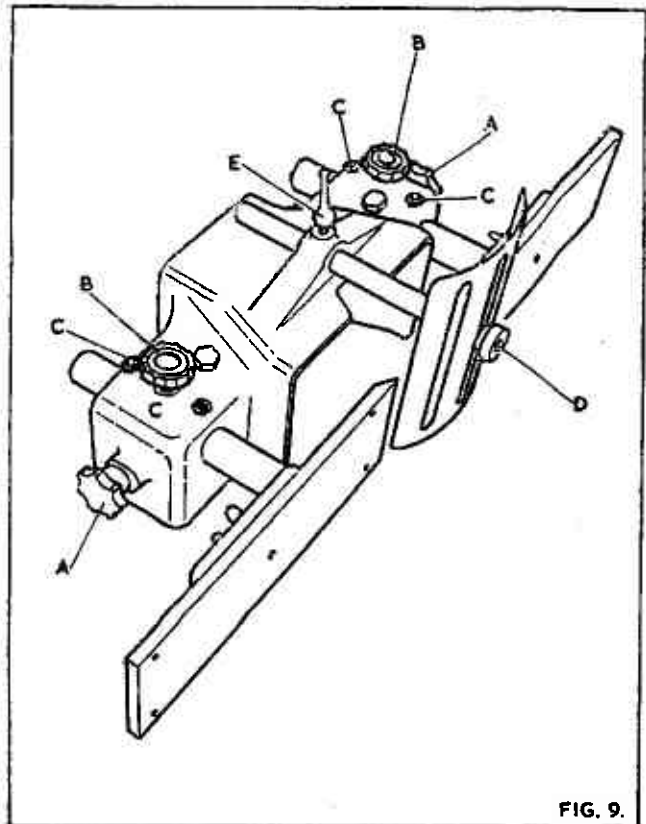

#### FENCE ADJUSTMENTS

Each fence plate can be independently adjusted by means of the plastic handwheels "A", in fig. 9. The fence plates can be set to the desired position and locked by the plastic handwheels "B". The front fence plates can be made either of metal or wood and are adjustable endwise.

The fence slide bars rest in accurately machined vee grooves and are held in position by the two brass grub screws on each bar. If the slide bars become slack adjust the grub screws "C" by the required amount and relock in position with the 3/8" whit. locknuts. The fence plates should be locked both ways at all times when the machine is in use.

The fence is fitted with a safety guard and a "Shaw" guard can also be fitted if required.

The safety guard is adjustable depending on the section of timber being worked. This guard is shown in position, in fig. 9. To adjust the guard for various sections of timber unscrew the knurled knob "D", set to required position and relock the knurled knob "D".

To adjust the safety guard in relation to the fence plates unscrew the two ball lever screw "E", position the safety guard and relock.

#### GENERAL HINTS

1. Use sharp cutters, reasonably balanced.
2. Make good robust jigs and ensure the parts are located securely on the jig.
3. NEVER run the cutter equipment at higher than the recommended speed.
4. Always use the guards available to ensure maximum protection.
5. Ensure the cutters are tight on the blocks before starting up. Use the spanners provided and never fit a piece of piping to get greater leverage. This will strain the nuts and bolts and ultimately make them unsafe.
6. NEVER pack the cutters with sandpaper. This is most dangerous as the grit collapses, when the cutter is working and the cutter works loose. For packing use one thickness only of thin brown paper
7. Keep nuts and bolts clean and use oil on the threads.
8. When changing cutter equipment always ensure the machine control lever is in the free or lock position. If in doubt isolate the machine electrically.

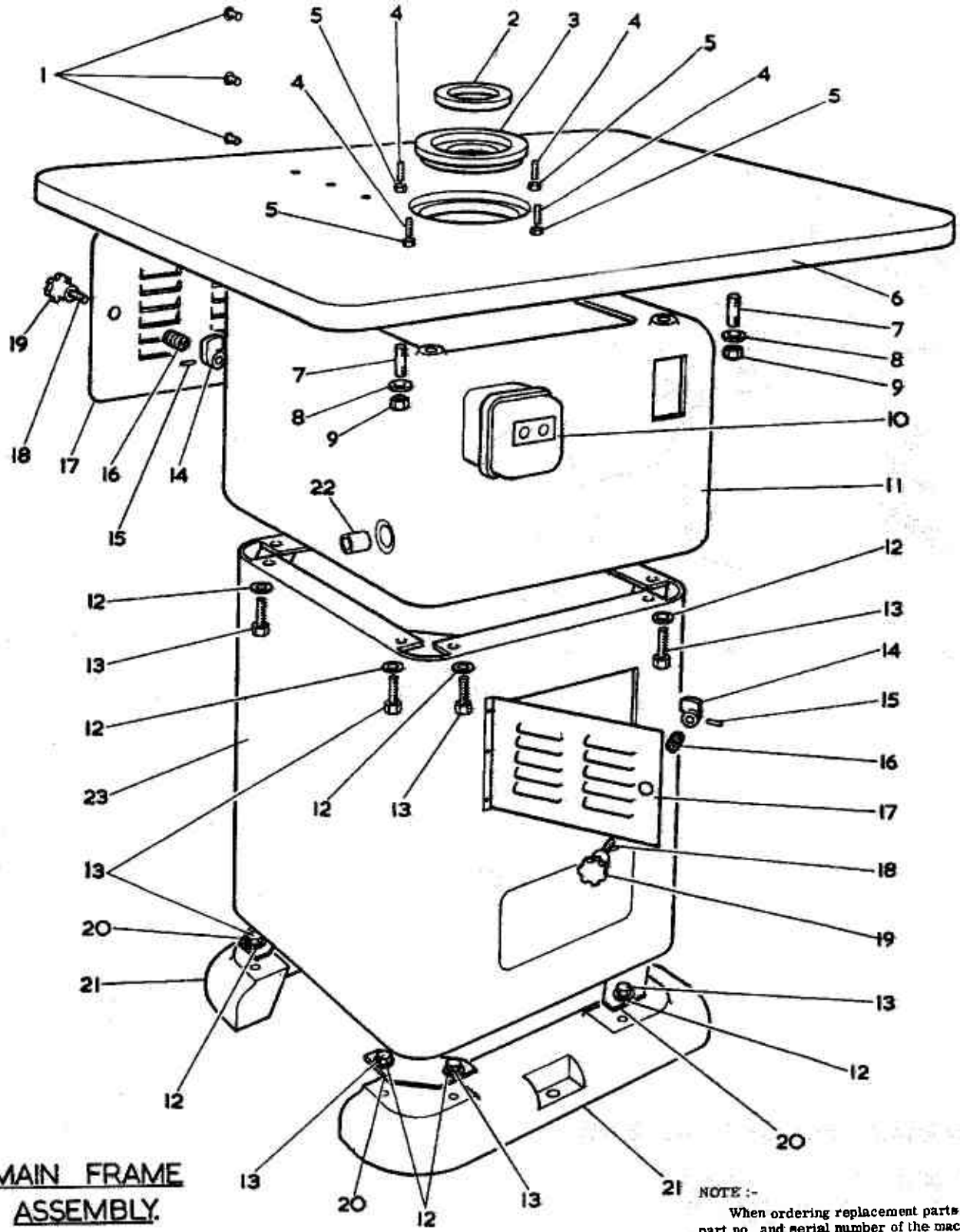

**MAIN FRAME ASSEMBLY.**

NOTE :-  
When ordering replacement parts quote part no. and serial number of the machine.

Ref No.	Part No.	No. Off	Description	Ref No.	Part No.	No. Off	Description
1		3	1/4" whit x 1/2" long round head screw	12		16	3/8" cadmium washer
2	B-1046/8	1	Small table ring	13		16	3/8" whit x 3/4" long cadmium hexagon head bolt
3	B-1046/7	1	Large table ring	14	A-1037/15	2	Door cam
4		4	3/16" whit x 3/4" long socket head grub screw	15		2	1/2" whit x 3/8" long socket head grubscrew
5		4	3/16" whit lock nut	16	A-1024/57	2	Spring for door lock
6	D-1046/2	1	Main table	17	C-1046/17	2	Door for base
7		4	3/8" whit x 1, 3/8" long stud	18	A-1039/31	2	Spindle for door cam
8		4	3/8" washer	19	Pat No. 14	3	2" dia. plastic handwheel, 1/2" whit
9		4	3/8" whit nut	20		4	Corner fillet for base
10	84 ADS	1	MEM Starter (3 phase, 3H. P. & 4H. P. 50 cycles)	21	C-1046/5	2	Foot for base
10	AT3	1	Brook Starter (3phase, 3 H. P. 60 cycles)	22		2	3/4" bore x 7/8" o/d x 1/4" long oilite bush
10	ZT3	1	Brook Starter (1 phase, 50 & 60 cycles)	23	D-1046/16	1	Sheet Steel Base
11	D-1046/1	1	Main frame				

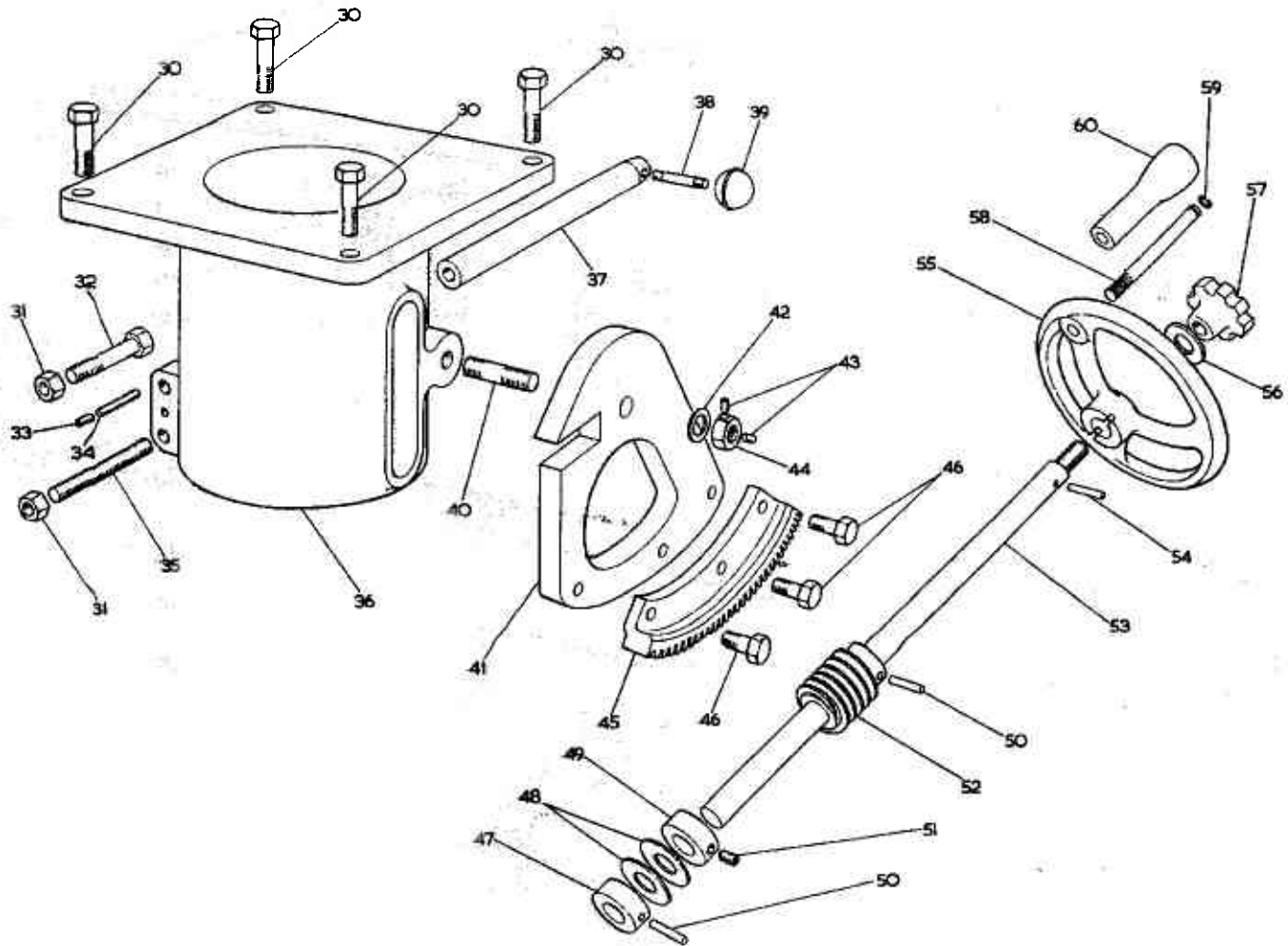

## SPINDLE HOUSING ASSEMBLY

NOTE :-

When ordering replacement parts quote part no. and serial number of the machine.

Ref No.	Part No.	No. Off	Description
30		4	3/8" whit x 1" long hexagon head bolt
31		2	1/2" whit nut
32		1	1/2" whit x 3" long hexagon head bolt
33		1	1/4" whit x 3/8" long socket head grubscrew
34		1	1/2" whit x 1" long socket head grubscrew
35	A-1046/47	1	Rise and fall locking stud
36	D-1046/3	1	Spindle housing bracket
37	A-1046/45	1	Quill Rise and fall locking shaft
38	A-1038/33	1	Quill locking handle
39	Patt No. 28	1	1 1/2" dia plastic ball 3/8" whit
40		1	5/8" whit x 2" long stud
41	C-1046/9	1	Rise and fall bracket
42		1	5/8" whit washer
43		2	1/2" whit x 1/4" long socket head grubscrew
44		1	5/8" whit locknut
45	3-1039/42A	1	Racked quadrant for rise and fall
46		3	3/8" whit x 1" long cadmium hexagon head bolt

Ref No.	Part No.	No. Off	Description
47	A-1026/29	1	Collar for rise and fall shaft (without 3/8" whit hole)
48	A-1026/65	2	Fibre washer for rise and fall shaft
49	A-1026/29	1	Collar for rise and fall shaft (with 3/8" whit hole)
50		2	3/16" dia x 1 1/2" long groverlok spring dowel
51		1	3/8" whit x 3/8" long socket head grubscrew
52	A-1026/32	1	Worm for rise and fall shaft
53	B-1046/44	1	Rise and fall shaft
54		1	3/16" whit x 1 1/4" long groverlok spring dowel
55	B-1026/8	1	Handwheel
56	A-1026/22	1	Washer for handwheel
57	Patt No. 14	1	2" dia plastic handwheel 1/2" whit T.R.T.
58	A-S-101	1	Spindle for 3" plastic handle
59	No. 5555-37	1	3/8" Grip ring circlip "Truearc"
60	Patt. No. 4	1	3" long plastic handle



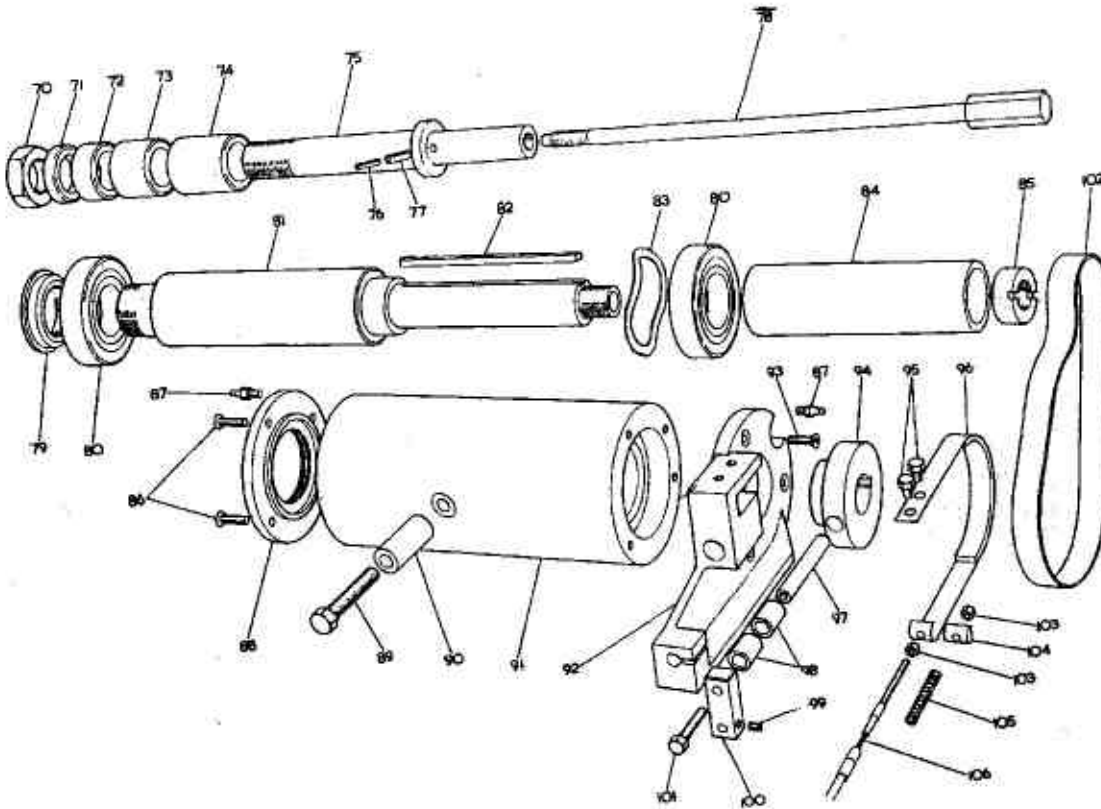

### SPINDLE ASSEMBLY

Ref No.	Part No.	No. Off	Description	Ref No.	Part No.	No. Off	Description
70	A-1046/32	1	Spindle nut (1 1/4" spindle)	88	B-1046/6	1	Dustcap for Quill
	A-1046/63	1	Spindle nut (30mm spindle)	89		1	1/2" whit x 3" long hexagon head bolt
71	A-1046/31	1	1/2" Spindle collar (1 1/4" bore)	90	A-1046/28	1	Rise and fall peg
	A-1792/152	1	6mm Spindle collar (30mm bore)	91	C-1046/4	1	Spindle Quill
72	A-1046/31	1	1/2" Spindle collar (1 1/4" bore)	92	C-1046/10	1	Brake housing for Quill
	A-1792/152	1	12mm Spindle collar (30mm bore)	93		3	1/4" whit x 2 1/2" long countersunk screw
73	A-1046/31	1	1" Spindle collar (1 1/4" bore)	94	B-1046/24	1	Brake drum
	A-1792/152	1	25mm Spindle collar (30mm bore)	95		2	5/16" whit x 1/2" long hexagon head bolt
74	A-1046/31	1	1 1/2" Spindle collar (1 1/4" bore)	96	B-1046/21	1	Band brake
	A-1792/152	1	38mm Spindle collar (30mm bore)	97	A-1046/37	1	Pin for spindle lock
75	B-1046/30	1	1 1/2" dia. work spindle	98		2	1/2" bore x 5/8" o/d x 1 1/2" long oilite bush
	B-1046/95	1	30mm dia. work spindle	99		1	1/4" whit x 3/4" long socket head grub screw
76		1	5/32" dia x 5/8" long groverlok spring dowel	100	A-1046/38	1	Link for spindle lock
77		1	1/4" dia x 5/8" long groverlok spring dowel	101		1	1/2" whit x 1" long bolt
78	B-1046/80	1	Spindle drawbolt	102		1	Meteor flat belt 22 1/2" long x 1" wide (3 phase, 50 cycles) <b>KS104429</b> <b>KS104427</b>
79	A-1046/23	1	Spindle top locknut			1 each	Meteor flat belt 24 1/2" long x 1" wide and 22" long x 1" wide (1 phase, 50 cycles)
80	6208. C50	2	S. K. F. Bearing			1	Meteor flat belt 21 1/2" long x 1" wide (3 phase, 4 H. P. 50 cycles) <b>KS104426</b>
81	C-1046/22	1	Main Spindle			2	1/2" B. S. F. nut
82		1	5/16" wide x 1/4" thick x 4.3/8" long key			1	Nipple for brake
83	EPL. 58	1	EMO. Pre-load waved washer	103	A-1046/85	1	Spring for brake cable
84	B-1046/25	1	50 cycle spindle pulley	104	A-1044/69	1	Cable assembly
85	B-1046/79	1	60 cycle spindle pulley	105		1	
86	A-1046/29	1	Spindle pulley locknut	106	B-1046/75	1	
		3	1/4" whit x 3/4" long socket head countersunk screw				
87	H. O. I. 1/4" B. S. F	2	Grease nipple straight type				

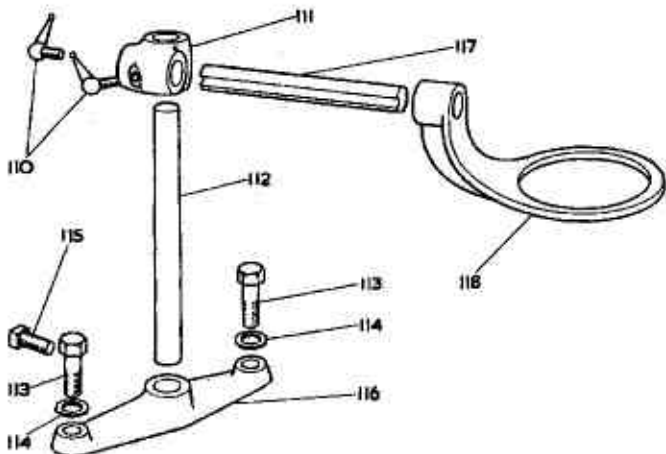

### RING FENCE ASSEMBLY EXTRA

Ref No.	Part No.	No. Off	Description
110	B-S-1-B	2	3/8" whit ball lever screw
111	B-1792/132	1	1" x 1/2" Filboe
112	D-1792/60	1	Ring fence column
113		2	1/2" whit x 1 1/2" long hexagon head bolt
114		2	1/2" whit washer
115		1	3/8" whit x 1/4" long square head bolt
116	C-1046/59	1	Bracket for ring fence column
117	A-1039/54	1	Ring fence arm
118	D-1792/56	1	Ring fence

NOTE:-

When ordering replacement parts quote part no. and serial number of the machine.



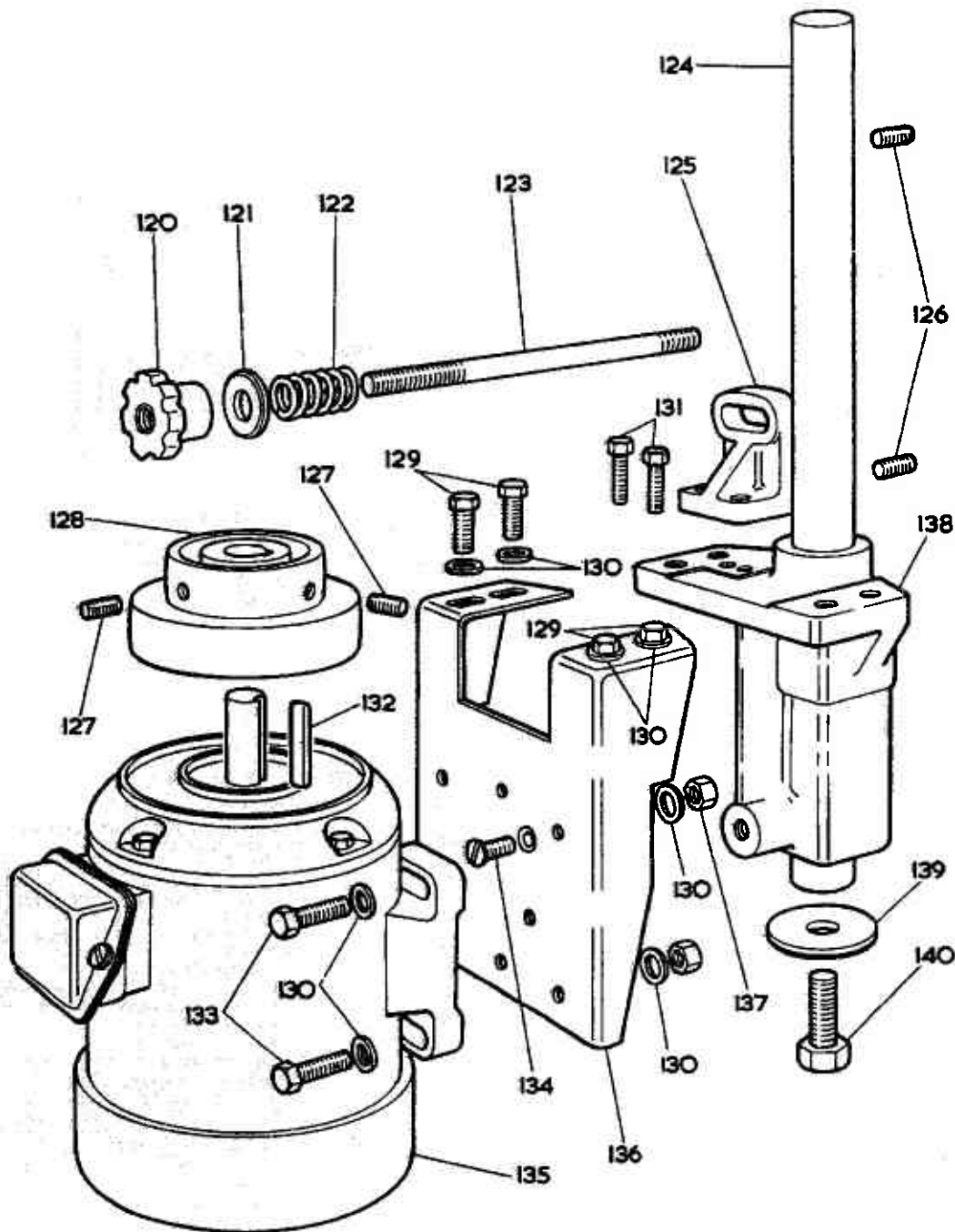

## MOTOR MOUNTING ASSEMBLY

NOTE :-

When ordering replacement parts quote part no. and serial number of the machine.

Ref No.	Part No.	No. Off	Description
120	Part No. 14	1	2" dia plastic handwheel $\frac{1}{2}$ " whit T. R. T.
121		1	$\frac{1}{2}$ " washer
122	A-1046/83	1	Spring for belt tension
123	A-1046/87	1	Stud for motor tension
124	A-1046/46	1	Motor pivot shaft
125	B-1046/14	1	Bracket for belt tensioning
126		2	$\frac{3}{8}$ " whit x 1" long socket head grubscrew
127		2	$\frac{1}{8}$ " gas x $\frac{1}{2}$ " long socket head grubscrew
128	B-1046/13	1	Motor pulley
129		4	$\frac{3}{8}$ " whit x $\frac{1}{2}$ " long cadmium hexagon head bolt
130		12	$\frac{3}{8}$ " cadmium washer
131		2	$\frac{5}{16}$ " whit x $\frac{3}{4}$ " long hexagon head bolt
132		1	$\frac{3}{16}$ " wide x 2" long key
133		4	$\frac{3}{8}$ " whit x $1\frac{1}{2}$ " long cadmium hexagon head bolt
134		1	$\frac{3}{8}$ " whit x $\frac{3}{4}$ " long countersunk screw

Ref No.	Part No.	No. Off	Description
135		1	Brook motor, M66, 3,000 R.P.M., 3 H.P. T. E. F. C. foot mounted (3 phase 50 cycles)
		1	Brook motor, M66, 3,600 R.P.M., 3 H.P. T. E. F. C. foot mounted (3 phase 60 cycles)
		1	Brook motor, D 184, 3,000 R.P.M., 3 H.P. T. E. F. C. foot mounted (1 phase 50 cycles)
		1	Brook motor, 90L, 3,000 R.P.M., 4 H.P. T. E. F. C. foot mounted (4 H.P., 3 phase, 50 cycles)
136	C-1046/88	1	Motor platform for M66 motor
	C-1046/78	1	Motor platform for 184 motor
	C-1026/12	1	Motor platform for 90L, motor
		4	$\frac{3}{8}$ " whit cadmium nut
137	D-1046/80	1	Motor pivot bracket
138	A-1002/52	1	Retaining washer
139		1	$\frac{1}{2}$ " whit x 1" long hexagon head bolt
140		1	

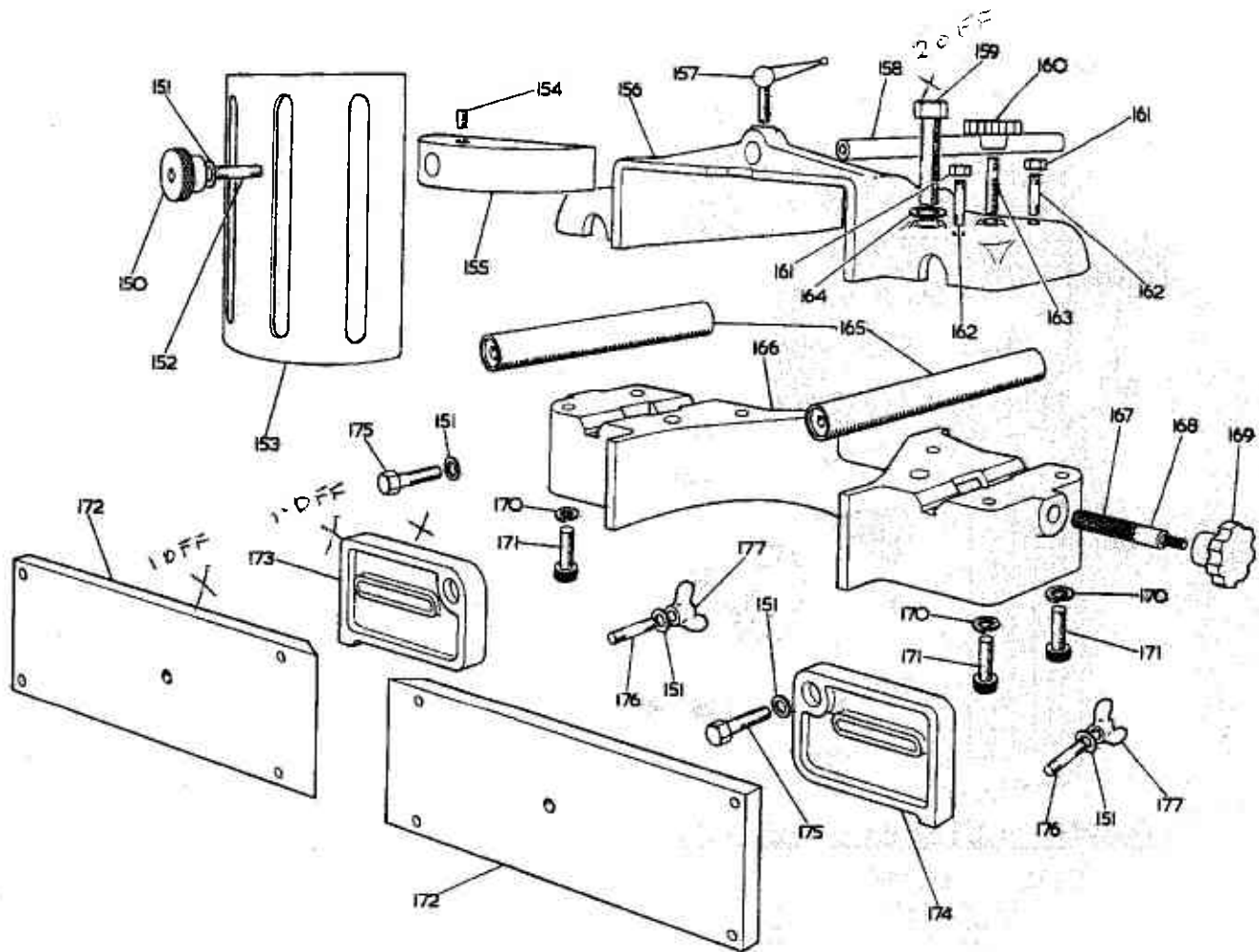

## FENCE ASSEMBLY

Ref No.	Part No.	No. Off	Description
150	A-1029/59	1	Knurled knob for guard
151		5	3/8" washer
152		1	3/8" whit x 1" long stud
153	B-1046/56	1	Shield for guard casting
154		1	3/8" whit x 3/8" long socket head grub screw
155	B-1046/52	1	Guard casting for adjusting fence
156	D-1046/50	1	Cover for adjusting fence frame
157	B-S-1-B	1	3/8" whit ball lever screw
158	A-1046/55	1	Arm for guard casting
159		2	1/2" whit x 5 1/2" long hexagon head bolt
160	Patt No. 32	2	1 1/4" dia. plastic handwheel 3/8" whit
161		4	3/8" whit locknut
162		4	3/8" whit x 1 1/4" long brass grub screw
163		2	3/8" whit x 1 1/4" long brass stud
164		2	1/2" washer

Ref No.	Part No.	No. Off	Description
165	A-1046/53	2	Fence rack bar
166	D-1046/49	1	Adjusting fence frame
167	A-1029/41	2	Fence adjusting pinion
168		2	5/16" bore x 1/2" o/d x 3/4" long oilite bush
169	Patt. No. 14	2	2" dia plastic handwheel 5/16" plain bore
170		6	3/8" whit spring washer
171		6	3/8" whit x 1" long socket head cap screw
172	B-1046/54	2	Fence front plate
173	B-1046/51	1	Right hand fence front adjusting bracket
174	B-1046/51	1	Left hand fence front adjusting bracket
175		2	3/8" whit x 1" long hexagon head bolt
176		2	3/8" whit x 1 1/2" long stud
177		2	3/8" whit wingnut

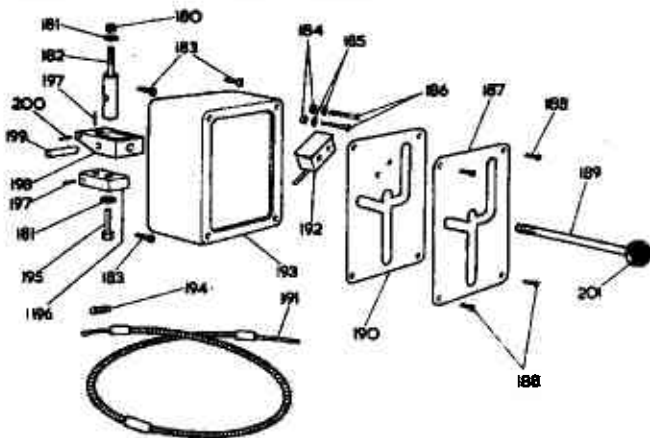

## CONTROL BOX ASSEMBLY

Ref No.	Part No.	No. Off	Description
180		1	1/2" whit aerotight nut
181		2	1/2" washer
182	A-1046/33	1	Brake swivel pin
183		4	1/2" whit x 3/4" long hexagon head bolt
184		2	3/16" whit nut
185		2	3/16" washer
186		2	3/16" whit x 1 1/2" long countersunk head screw
187	B-1046/20	1	Instruction plate for control box
188		4	1/2" whit x 1/2" long round head screw
189	A-1046/40	1	Control handle
190	B-1046/19	1	Cover for control box
191	B-1046/75	1	Cable assembly
192	C. Y. W. 2	1	Burgess micro switch
193	C-1046/18	1	Control box
194	A-1046/84	1	Spring for handle
195		1	1/2" whit x 1 1/2" long hexagon head bolt
196	A-1046/34	1	Brake top anchor plate
197		2	1/2" whit x 3/8" long socket head grub screw
198	B-1046/15	1	Yoke for brake
199	A-1046/35	1	Brake pivot pin
200		1	1/2" whit x 1/2" long socket head grub screw
201	Patt No. 28	1	1 1/4" dia plastic ball, 3/8" whit

NOTE :-

When ordering replacement parts quote part no. and serial number of the machine.

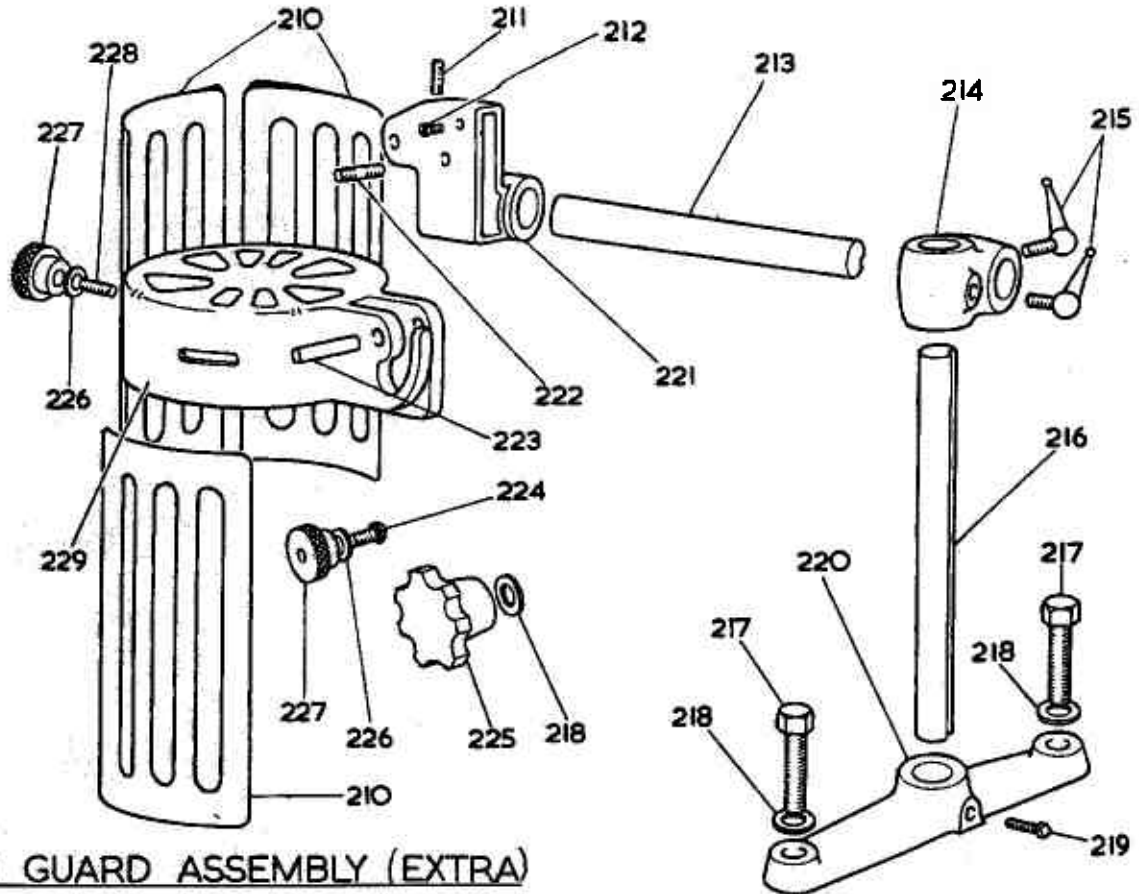

**RING GUARD ASSEMBLY (EXTRA)**

Ref No.	Part No.	No. Off	Description
210	D-1792/109	3	Shield for canting ring guard
211		1	1/2" whit x 3/8" long socket head grubscrew
212		1	1/4" whit x 1/2" long cheese head screw
213	D-1792/113	1	Arm for canting ring guard
214	D-1792/114	1	1" x 1" filboe for canting ring guard
215	B-S-1-B	2	3/8" whit ball lever screw
216	D-1792/60	1	Ring guard column
217		2	1/2" whit x 1 1/2" long hexagon head bolt
218		3	3/8" washer
219		1	3/8" whit x 2" long square head bolt

Ref. No.	Part No.	No. Off	Description
220	C-1046/59	1	Foot for ring guard
221	D-1792/111	1	Pivot bracket for canting ring guard
222		1	1/2" whit x 1 1/4" long stud
223	D-1792/112	1	Pivot pin for canting ring guard
224		2	3/8" whit x 1" long coachbolt
225	Pat. No. 14	1	3" dia. plastic handwheel, 1/2" whit blind
226		3	3/8" washer
227	A-1029/59	3	Knurled knob for guard
228		1	3/8" whit x 1" long stud
229	D-1792/110	1	Top piece for canting ring guard

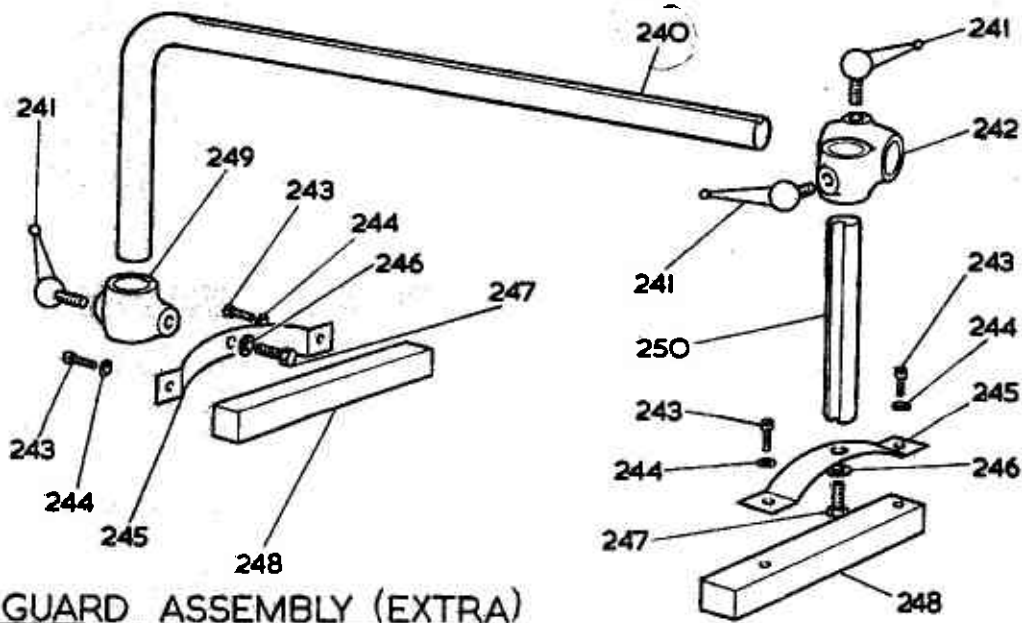

**SHAW GUARD ASSEMBLY (EXTRA)**

Ref No.	Part No.	No. Off	Description
240	A-1046/57	1	Shaw guard cantilever arm
241	B-S-1-B	3	3/8" whit ball lever screw
242	D-1792/65	1	5/16" x 1" filboe
243	No. 8	4	1" long black japanned round head screw
244		4	3/16" washer
245	D-1792/45	2	Shaw guard pressure spring

Ref. No.	Part No.	No. Off	Description
246		2	5/16" spring washer
247		2	5/16" whit x 1/2" long hexagon head bolt
248	D-1792/44	2	Wood shoes for shaw guard
249	A-1039/14	1	Front pressure bracket for shaw guard
250	A-1046/58	1	Shaw guard top pressure bar

## EXTRA EQUIPMENT

11.

### GUARDS & FENCES.

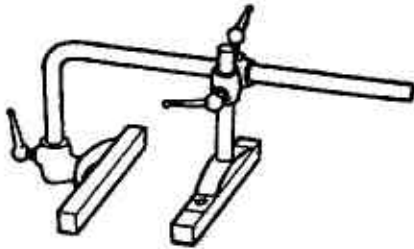

**SHAW GUARD** :- This guard provides top and side pressures and ensures safety in operation for use with the standard fence or as effectively with the ring fence for curved work.

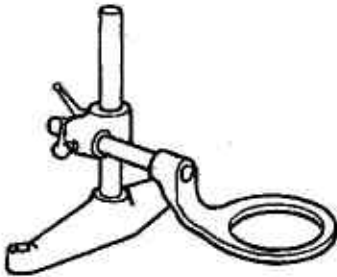

**RING FENCE** :- This fence is for use on all types of curved work.

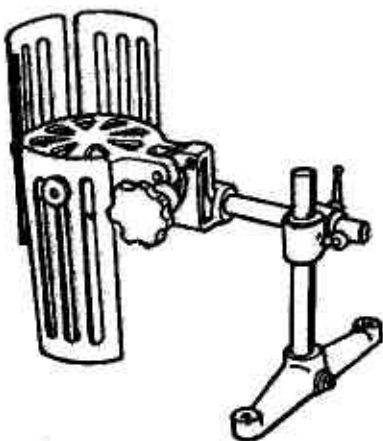

**SAFETY GUARD** :- This guard has adjustable flaps and is for use with the ring fence and completely covers the work spindle and cutter equipment. The guard swings away for ease of access when setting the cutters.

### ATTACHMENTS.

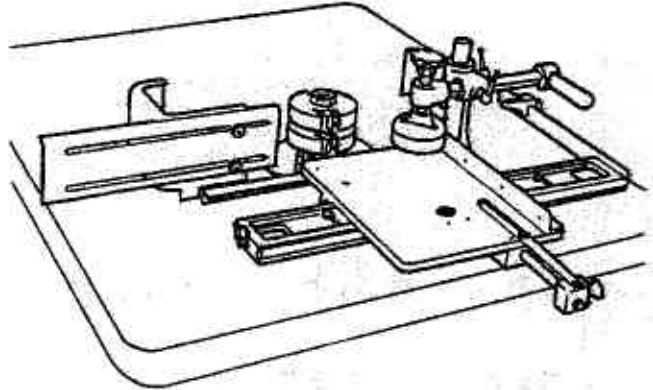

**SLIDING TABLE TENONING ATTACHMENT** :- This can be quickly adapted for a variety of tenoning operations. The maximum size of timber which can be admitted is 10" wide x 3" deep (254mm x 76mm). Using two 5" dia. (127mm) cutterblocks tenons up to 2" long (50mm) can be cut in one pass. This attachment can also be used for other operations such as halflapping, corner locking and for short panels and caps which are difficult to hold by hand. Using a 4" dia. (101mm) flush mounted cutterhead tenons up to 4½" long (113mm) can be cut at two passes by turning the timber over.

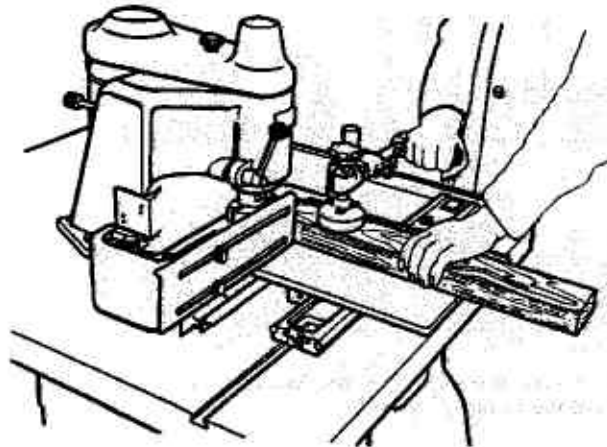

**OVERHEAD TYPE TENONING ATTACHMENT** :- When used in conjunction with the sliding table attachment and 4" dia. (101 mm) flush mounted cutterheads, tenons up to 4½" (113 mm) long can be cut in one pass and 6" (152 mm) long in two passes. This attachment is a self contained unit with a 2 H.P. motor and flat belt drive to the spindle. It can be quickly offset in relation to the machine spindle for unequal tenons.

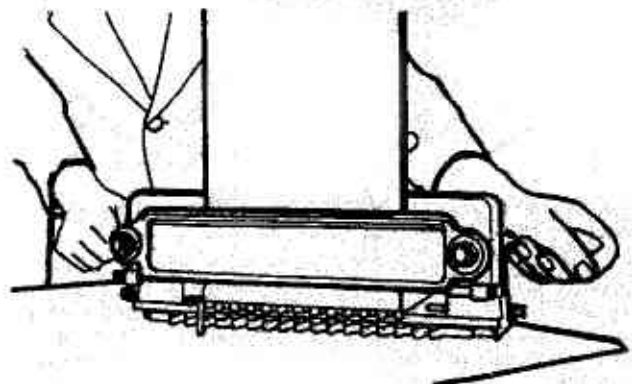

**DOVETAIL ATTACHMENT TYPE EE:-** For board up to 12" (305 mm) wide supplied complete with comb plate, collet adaptor and 3/8" dia. (9 mm) H, type collet.

This attachment is a very simple efficient device for dovetailing two boards at right angles to each other. They are clamped in position and suitable stops are provided for setting. Both the dovetail and the pin are produced at the same operation, and the pin is rounded so that no hand work is necessary.

Guide plates and bits are available for the following pitches 1/2", 5/8", 3/4", 1", 1 1/4" and 1 1/2". (13 mm, 16mm, 19mm, 25mm, 32 mm and 38 mm).

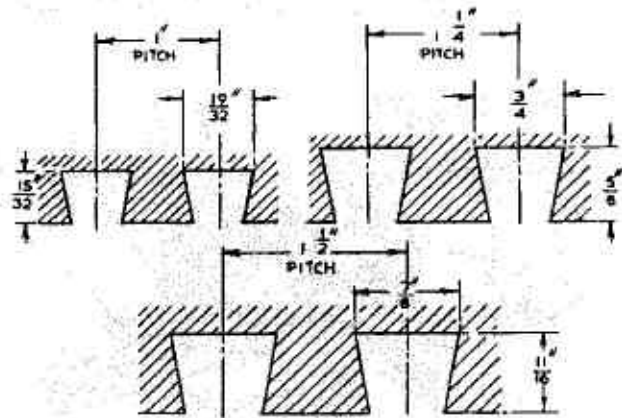
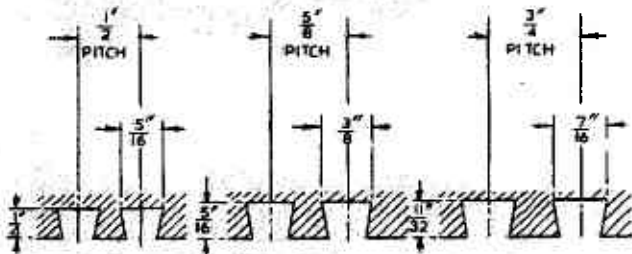

Note:- When ordering spare dovetail bits, please specify pitch size not the diameter of the bit.

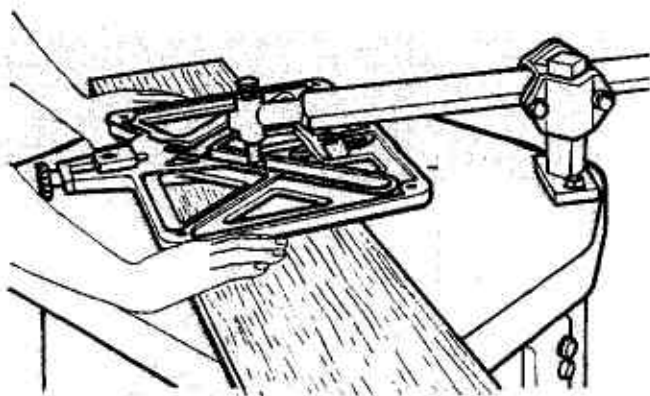

**STAIR HOUSING ATTACHMENT:-** This attachment consists of template guide roller, arm and pillar.

This attachment can be fitted in a few minutes. The roller guide which controls the cut, is rigidly carried on a solid steel arm from a pillar and centred with the spindle. The template is secured to stair string by means of a hand nut. The template is reversible to produce a pair of strings right and left hand without resetting. Marking out is practically eliminated and a complete pair of strings can be cut in less time than is normally taken in marking out.

## SPINDLES AND ADAPTORS.

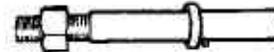

**STANDARD LOOSE SPINDLES :-** 3/4", 1" or 1 1/4" dia (20mm, 25mm and 30mm) available. These are for carrying standard bore cutter blocks, slotted collars, grooving saws, etc. The spindle threads are right hand, and all spindles are supplied with locknut and a set of making up collars.



**SLOTTED FRENCH SPINDLE :-** For carrying one 1/4" (6mm) thick cutter only, which is secured by a hardened steel set screw. Maximum recommended speed :- 4,500 rpm

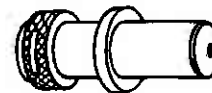

**COLLET TYPE ROUTER ADAPTOR :-** This adaptor is supplied complete with 3/8", 1/2" and 9/16" (9mm, 13mm, and 14mm) "H" type collets. It enables standard router cutters to be used.

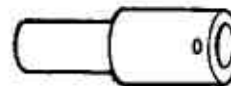

**ADAPTOR FOR STAIR HOUSING ATTACHMENT :-** Special adaptor having a 5/8" bore (16mm) to accept both "Z" type of clothes peg type cutter



**ADAPTOR SPINDLE FOR TENONING ATTACHMENTS :-** This spindle is specially screwed for a flush mounted cutterhead and is available for both the standard machine and the overhead tenoning attachment. These spindles with a flush mounted cutterhead are particularly suitable for working drip grooves in sills and other large sections as well as for use with the tenoning attachment.

## CUTTER EQUIPMENT

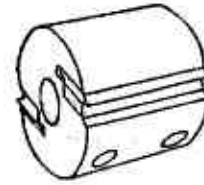
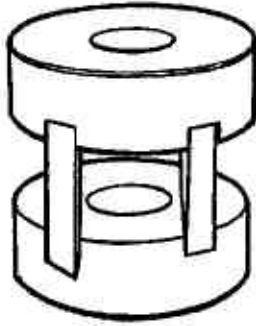

### PLAIN SLOTTED COLLARS :-

For  $\frac{3}{4}$ " (20mm) dia. work spindle :-  $2\frac{1}{4}$ " (57mm) dia. with  $\frac{1}{4}$ " (6mm) wide slots.

Minimum cutting circle :-  $2\frac{1}{4}$ " (70mm)

For 1" (25mm) dia. work spindle :-  $2\frac{1}{2}$ " (64mm) dia. with  $\frac{1}{4}$ " (6mm) wide slots

Minimum cutting circle :- 3" (76mm)

For  $1\frac{1}{4}$ " (30mm) dia. work spindle :- 3" (76mm) dia. with  $\frac{1}{4}$ " (6mm) wide slots

Minimum cutting circle :-  $3.5\frac{5}{8}$ " (92mm)

Slotted collar cutters have many advantages, they have a good cutting angle, a comparatively small cutting circle and are easy to shape, maintain and re-grind and also inexpensive. The maximum cutter projection should not exceed  $\frac{5}{8}$ " (16mm) to ensure maximum strength and support.

$2\frac{1}{2}$ " (64mm) dia x 1" bore or  $\frac{3}{4}$ " (25mm or 20mm) bore ball bearing type slotted collars also available.

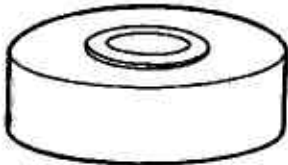

**BALL BEARING GUIDES :-** Available in two sizes for  $3\frac{1}{2}$ " and 4" cutterblocks (89mm and 101mm)

$3\frac{1}{2}$ " (89mm) dia x  $\frac{3}{4}$ " (20mm) or 1" (25mm) bore.

4.  $1\frac{1}{8}$ " (104mm) dia x  $\frac{3}{4}$ " (20mm) or 1" (25mm) bore.

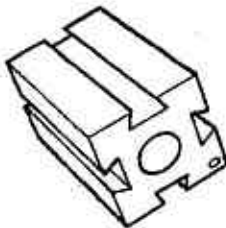

**SQUARE CUTTERBLOCKS :-** These cutterblocks are used for long runs, cutters working in pairs. Two or more pairs may be mounted on a single block to build up a mould.

For 1" dia. (25mm) work spindle :-

$2\frac{1}{2}$ " (64mm) square x 3" (76mm) long complete with 4 -  $\frac{1}{2}$ " whit (13mm) dovetails cutter bolts, nuts and washers.

Maximum recommended speed :- 4,500 rpm.

For  $1\frac{1}{4}$ " dia work spindle

$3\frac{1}{2}$ " (89mm) square x 3" (76mm) long complete with 4 -  $5\frac{1}{8}$ " whit dovetail cutter bolts, nuts and washers.

Maximum recommended speed :- 4,500 rpm.

**CIRCULAR CUTTERBLOCKS :-** These cutterblocks have wedge type clamping for safety. They are smooth running and used for facing or shallow rebates etc.

For 1" dia. work spindle :-

$3\frac{1}{2}$ " (89mm) diameter circular cutterblock, 3" (76mm) long or 2" (50mm) long.

Maximum recommended speed :- 7,000 rpm

For  $1\frac{1}{4}$ " dia. work spindle :-

$4\frac{1}{4}$ " (102mm) diameter circular cutterblock, 3" (76mm) long.

Maximum recommended speed :- 7,000 rpm

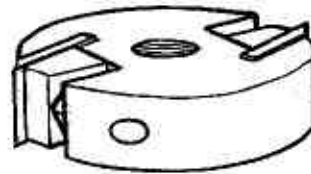

### FLUSH MOUNTED CUTTERHEAD :-

4" (102mm) diameter with screwed bore, for use with special 4" adaptor spindle.

For standard machine right hand thread.

For overhead tenoning attachment left hand thread.

Maximum recommended speed :- 7,000 rpm.

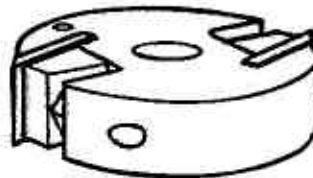

### TWO KNIFE WEDGE TYPE MOULDING CUTTERBLOCK

These cutterblocks are designed to take from  $\frac{5}{32}$ " (4mm) to  $\frac{1}{4}$ " (6mm) thick cutters this permits tungsten carbide tipped cutters to be used when necessary.

The cutters can be used for mouldings requiring up to  $\frac{1}{2}$ " (13mm) cutter projection when using  $\frac{1}{4}$ " thick cutters 4" (102mm) dia x  $15\frac{1}{16}$ " (24mm) thick x 1" (25mm) bore Part No. QR60.

This block uses  $\frac{5}{32}$ " (4mm) thick cutters only.

4.  $7\frac{7}{8}$ " (124mm) dia. x  $15\frac{1}{16}$ " (8mm) thick x 1" (25mm) bore. Part No. QR 11/B

4.  $7\frac{7}{8}$ " (124mm) dia. x  $15\frac{1}{16}$ " (8mm) thick x  $1\frac{1}{4}$ " (30mm) bore. Part No. QR 1/B

4.  $7\frac{7}{8}$ " (124mm) dia. x  $1\frac{1}{4}$ " (32mm) thick x  $1\frac{1}{4}$ " (30mm) bore. Part No. QR 2

4.  $7\frac{7}{8}$ " (124mm) dia. x  $1\frac{1}{4}$ " (38mm) thick x  $1\frac{1}{4}$ " (30mm) bore. Part No. QR 10.

4.  $7\frac{7}{8}$ " (124mm) dia x 2" (50mm) thick x  $1\frac{1}{4}$ " (30mm) bore. Part No. QR 3

4.  $7\frac{7}{8}$ " (124mm) dia. x 2" (50mm) thick x  $1\frac{1}{4}$ " (30mm) bore. 4 Knife Part No. QR 66

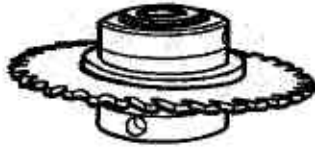

**WOBBLE SAW :-**

These saws are used where varied widths of grooving are called for, and where quantities are small. They are not recommended for quantity production or where precision accuracy or the highest standard of finish is required.

- 6" (151mm) diameter for grooves 1/8" to 3/4" (3mm to 19mm)  
For use on 1" and 1 1/4" dia (25mm and 30mm) spindles.
  - 4" (102mm) diameter for grooves 1/8" to 1/2" (3mm to 13mm)  
For use on 3/4" (20mm) dia spindles.
- Maximum recommended speed. 4,500 r.p.m.

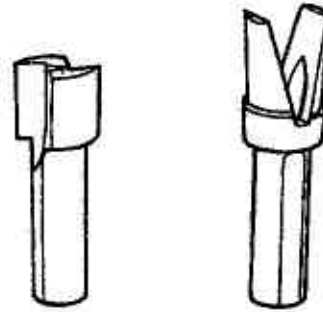

**CUTTERS FOR STAIR HOUSING ATTACHMENT:-**

Z Type and Clothes peg type 5/8" dia shank.

These cutters are designed to give a slightly undercut trench and perfectly uniform wedge space. All have 5/8" dia shank.

**CUTTERS.**

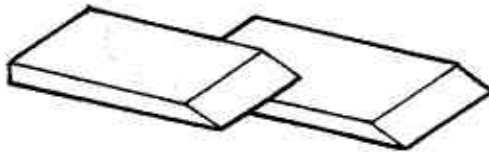

**CUTTERS FOR SQUARE CUTTERBLOCKS & SLOTTED COLLARS**

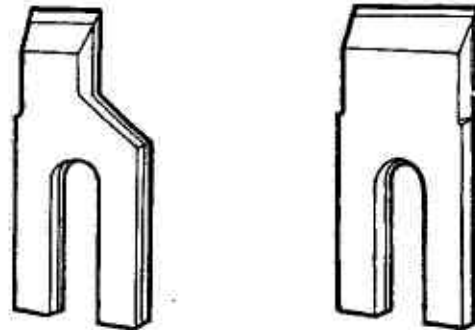

**CUTTERS FOR QR BLOCKS**

**VZ Cutters 5/32" thick**

3/4"	on cut	VZ
1"	on cut	VZ1
1 1/4"	on cut	VZ2
1 1/2"	on cut	VZ3
1 3/4"	on cut	VZ4
2"	on cut	VZ5
2 1/2"	on cut	VZ6

**T.C. Tipped**

VZ/T
VZ1/T
VZ2/T
VZ3/T
VZ5/7

**1/4" Thick**

3/4"	on cut	VZ20
1"	on cut	VZ21
1 1/4"	on cut	VZ22
1 1/2"	on cut	VZ23
1 3/4"	on cut	VZ24
2"	on cut	VZ25
2 1/4"	on cut	VZ26
2 1/2"	on cut	VZ27

**T.C. Tipped**

VZ21/T
VZ22/T
VZ23/T

**Rebate & Square Irons**

For 2 1/2" square cutterblock :-

**Rebate Irons**

**Part Nos.**

On Cut	R. H.	L. H.
1/2"	VQ1	VQ2
5/8"	VQ3	VQ4
3/4"	VQ5	VQ6
7/8"	VQ7	VQ8
1"	VQ9	VQ10
1 1/4"	VQ11	VQ12

**Square Irons**

On Cut	Part Nos.
1 1/2"	VQ13
1 3/4"	VQ14
2"	VQ15
2 1/8"	VQ16
2 1/2"	VQ17
3"	VQ18

**Router Cutters:**

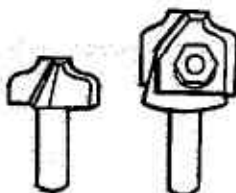

For 3 1/2" square cutterblock :-

**Rebate Irons**

**Part Nos.**

On Cut	R. H.	L. H.
1/2"	TB1	TB2
5/8"	TB3	TB4
3/4"	TB5	TB6
7/8"	TB7	TB8
1"	TB9	TB10
1 1/4"	TB11	TB12
1 1/2"	TB13	TB13a

**Square Irons**

On Cut	Part Nos.
1 3/4"	TB14
2"	TB15
2 1/8"	TB16
2 1/2"	TB17
2 3/4"	TB18
3"	TB19



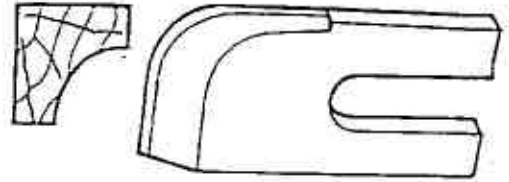
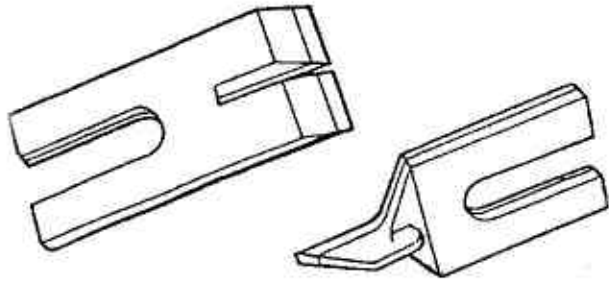

**Tonguing and Grooving Irons**

For 2 1/2" square cutterblock :-  
Part No.

For 3 1/2" square cutterblock :-  
Part No.

Size	Tonguing Cutter	Grooving Cutter	Tonguing Cutter	Grooving Cutter
1/8"	VS1	VR1	TV	TX
3/16"	VS2	VR2	TV1	TX1
1/4"	VS3	VR3	TV2	TX2
5/16"	VS4	VR4	TV3	TX3
3/8"	VS5	VR5	TV4	TX4

**Scotia Cutters**

For 2 1/2" sq. cutterblock

For 3 1/2" sq. cutterblock

For 2 1/2" dia Slotted Collars

For 3" dia Slotted Collars

Dim A.	Part No.	Part No.	Part No.	Part No.
1/4"	BTJ1	TJ1	BTL1	TL1
3/8"	BTJ2	TJ2	BTL2	TL2
1/2"	BTJ3	TJ3	BTL3	TL3
5/8"	BTJ4	TJ4	BTL4	TL4
3/4"	BTJ5	TJ5	BTL5	TL5
7/8"	BTJ6	TJ6	BTL6	TL6
1"	BTJ7	TJ7	BTL7	TL7

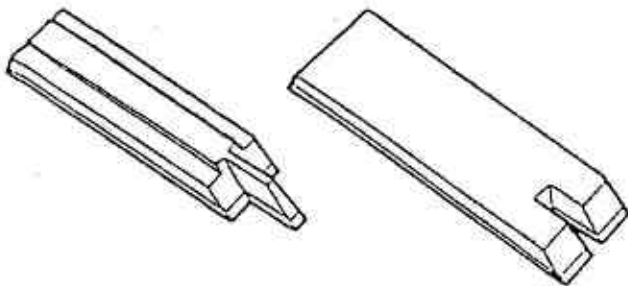

For 2 1/2" dia slotted collars :-  
Part No.

For 3" dia slotted collars :-  
Part No.

**Beading Cutters**

For 2 1/2" sq. cutterblock

For 3 1/2" sq. cutterblock

For 2 1/2" dia Slotted Collars

For 3" dia Slotted Collars

Size	Tonguing Cutter	Grooving Cutter	Tonguing Cutter	Grooving Cutter	Dim. A	Part No.	Part No.	Part No.	Part No.
3/16"	BVL1	BVJ1	VL1	VJ1	1/4"	BTN1	TN1	BTP1	TP1
1/4"	BVL2	BVJ2	VL2	VJ2	3/8"	BTN2	TN2	BTP2	TP2
5/16"	BVL3	BVJ3	VL3	VJ3	1/2"	BTN3	TN3	BTP3	TP3
3/8"	BVL4	BVJ4	VL4	VJ4	5/8"	BTN4	TN4	BTP4	TP4
					3/4"	BTN5	TN5	BTP5	TP5
					7/8"	BTN6	TN6	BTP6	TP6
					1"	BTN7	TN7	BTP7	TP7
					1.1/8"	BTN8	TN8	BTP8	TP8
					1 1/4"	BTN9	TN9	BTP9	TP9
					1.3/8"	BTN10	TN10	BTP10	TP10
					1 1/2"	BTN11	TN11	BTP11	TP11

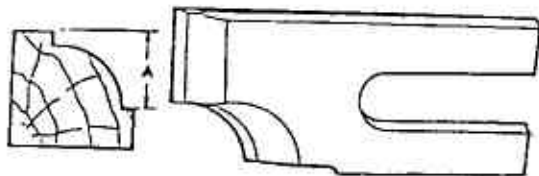

**Ovolo Cutters**

For 2 1/2" Square Cutterblock

For 3 1/2" Square Cutterblock

Dim A.	Part No.	Part No.
1/4"	BTF1	TF1
3/8"	BTF2	TF2
1/2"	BTF3	TF3
5/8"	BTF4	TF4
3/4"	BTF5	TF5
7/8"	BTF6	TF6
1"	BTF7	TF7

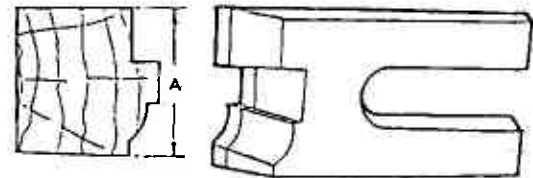

For 2 1/2" dia. Slotted Cutterblock

For 2 1/2" dia. Slotted Collars

For 3" dia. Slotted Collars

Dim A.	Part No.	Part No.
1/4"	BTH1	TH1
3/8"	BTH2	TH2
1/2"	BTH3	TH3
5/8"	BTH4	TH4
3/4"	BTH5	TH5
7/8"	BTH6	TH6
1"	BTH7	TH7

**Sash Cutters**

For 2 1/2" sq. cutterblock

For 3 1/2" sq. cutterblock

For 2 1/2" dia Slotted Collars

For 3" dia Slotted Collars

Dim A	Part No.	Part No.	Part No.	Part No.
1.1/8"	BTR1	BTR1	BTT1	TT1
1.5/8"	BTR2	TR2	BTT2	TT2
1.7/8"	BTR3	TR3	BTT3	TT3

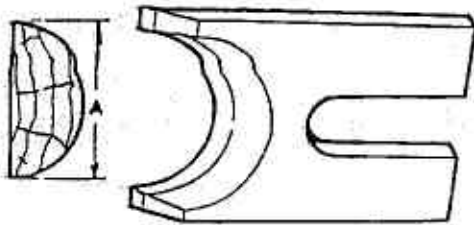

**Full Nosing Cutters**

diam A	For 2 1/2" sq. cutterblock		For 3 1/2" sq. cutterblock		For 2 1/2" dia Slotted Collars		For 3" dia Slotted Collars	
	Part No.	Part No.	Part No.	Part No.	Part No.	Part No.	Part No.	
1/2"	BVF1	VF1	BVH1	VH1				
5/8"	BVF2	VF2	BVH2	VH2				
3/4"	BVF3	VF3	BVH3	VH3				
7/8"	BVF4	VF4	BVH4	VH4				
1"	BVF5	VF5	BVH5	VH5				
1.1/8"	BVF6a	VF6a	BVH6a	VH6a				
1 1/2"	DVF6	VF6	BVH6	VH6				
1 3/4"	BVF7	VF7	BVH7	VH7				
1 7/8"	DVF8	VF8	BVH8	VH8				
2"	BVF9	VF9	BVH9	VH9				

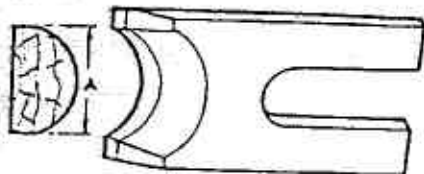

**Shallow Nosing Cutters**

diam A	For 3 1/2" sq. cutterblock		For 3" dia Slotted Collars	
	Part No.	Part No.	Part No.	Part No.
1/2"	VB1	VD1		
5/8"	VD2	VD2		
3/4"	VB3	VD3		
7/8"	VB4	VD4		
1"	VB5	VD5		
1 1/8"	VB6	VD6		
1 1/4"	VB7	VD7		
1 3/4"	VB8	VD8		
2"	VB9	VD9		

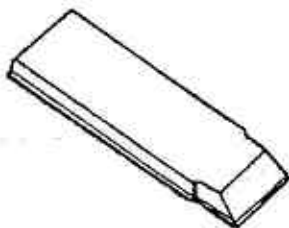

**Edge Cutters**

Cut	For 2 1/2" dia Slotted Collars		For 3" dia Slotted Collars	
	Part No.	Part No.	Part No.	Part No.
	BVN1	VN1		
	BVN2	VN2		
	BVN3	VN3		
	BVN4	VN4		
	BVN5	VN5		
	BVN6	VN6		
	BVN7	VN7		
	BVN8	VN8		
	BVN9	VN9		
	BVN10	VN10		

**CUTTERS AND CUTTER STEELS FOR SPINDLE MOULDERS**

Special grades of steel are used for making cutters for different duties and applications on the spindle moulder. The following is a rough guide.

High speed steel on iron :- is used for long life and for cutting hard woods. High speed steel is brittle and is usually welded to a softer steel back for all types of unsupported irons. These are used on square cutterblocks, slotted collars and some thin knife moulding cutterblocks. A large range of irons for the square cutterblock and slotted collars are readily available in this steel.

Solid high speed steel :- is more brittle and is only used where the cutters are supported very close up to the cutting edge e.g. a thin knife on the circular cutterblock, or where a strong section can be used such as a milled to pattern slotted collar cutter.

Alloy steel on iron :- is less expensive than high speed steel on iron, and is more ductile. Alloy steel is not as hard and will not stand up to heavy cutting or hard woods as well as high speed steel. A large range of irons for the square cutterblock and slotted collars are readily available in this steel.

Solid alloy steel :- is normally supplied in bar form in the soft condition for cutting up by the customer. It is easily hardened and tempered and is normally used for french spindle work up to 6,000 rpm where cutters are held by a locking screw in spindle, locking direct on to the side of the cutter.

All the above types can be supplied in bar form, micrometer ground to precision limits. The alloy and iron on iron 3/16" (5mm) x 1/2" (20mm) up to 1/2" (6mm) x 3" (76mm) in the soft condition and the solid high speed steel 5/32" (4mm) x 1 1/2" (38mm) and 5/32" (4mm) x 2" (50mm) and high speed steel on iron 1/2" (6mm) x 1 1/2" (32mm) and 1/2" (6mm) x 1 1/2" (38mm) in the head treated condition. These latter bars cannot be cut with a tool and the blanks should be ordered to correct grinding lengths unless the user has suitable grinding wheel equipment for cutting to length himself.

All the above cutters can be ground on the usual standard grinding equipment.

Tungsten carbide tips :- These are specially made for use on hardwoods, woods with high silica content also plywoods and hardboards where High Speed Steel will not stand up to the abrasive action. It is much more expensive but gives very much longer life. A limited range of these cutters for slotted collars and square cutterblocks are available. Special shapes can be supplied to order.

N.B. Special diamond impregnated grinding wheels and diamond hand caps are essential for shaping and servicing Tungsten Carbide Tipped Tools. These are available but expensive for the small user for whom we can offer a cutter grinding service if required.

**SHAPING CUTTERS**

When shaping cutters for any mould on any type of cutterhead or slotted collars it is important that the correct allowance is made to the depth of form cutter.

Fig. 10 shows the projections of the cutter to produce a simple rebate. For example using the 3 1/2" square cutterblock, to produce a 1" (25mm) deep rebate the cutter must have a depth of form of 1.3/16" (30mm) this being due to the angle at which the cutter strikes the work on the line "AA". When a shaped mould is required to be cut it is necessary to plot out the form of the cutter; this is shown in fig. 11.

It is important when selecting blanks from which to make the cutter that they have the minimum necessary overhang. Also a blank as near the shape and width as possible should be selected so that there will be less waste and less change of overheating cutters when grinding.

The minimum cutting circle is fixed to give the necessary clearance for the bolt head when working with straight irons only.

The cutting angle which is normally 35° is shown at "B", in fig. 10 and the cutting and the cutting angle at "C" this angle varies with the size of the cutterblock and the depth of the mould.

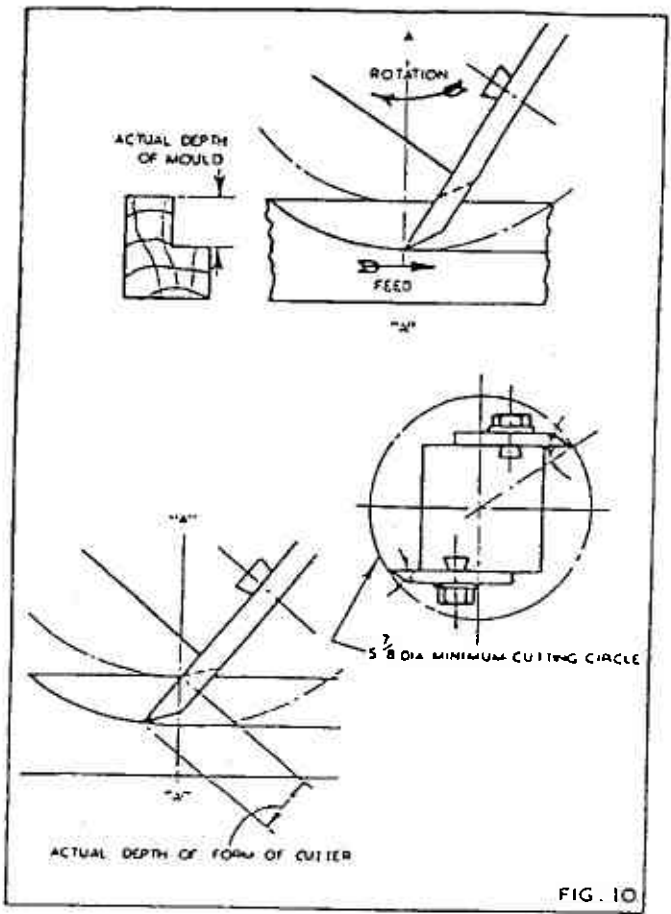

FIG. 10

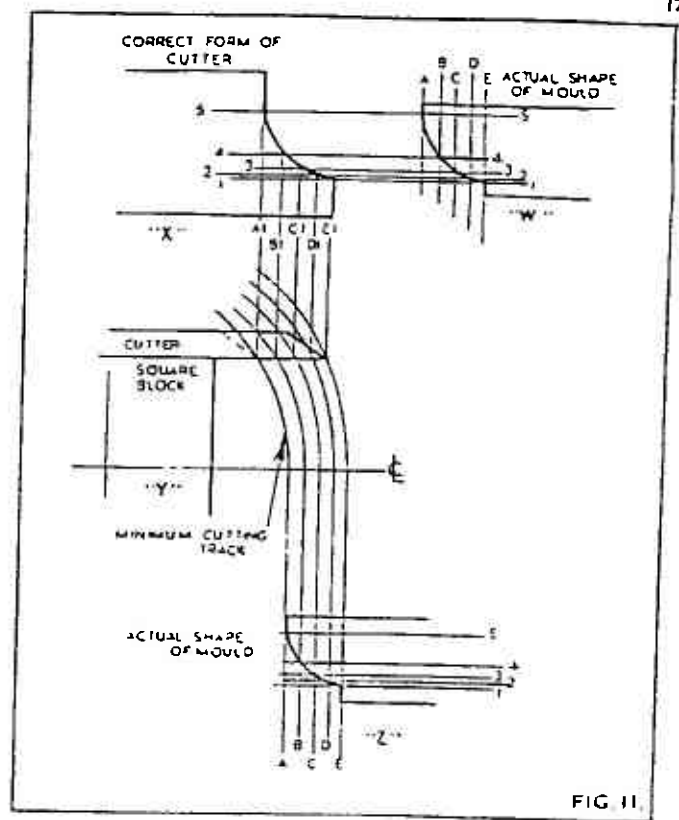

FIG. 11

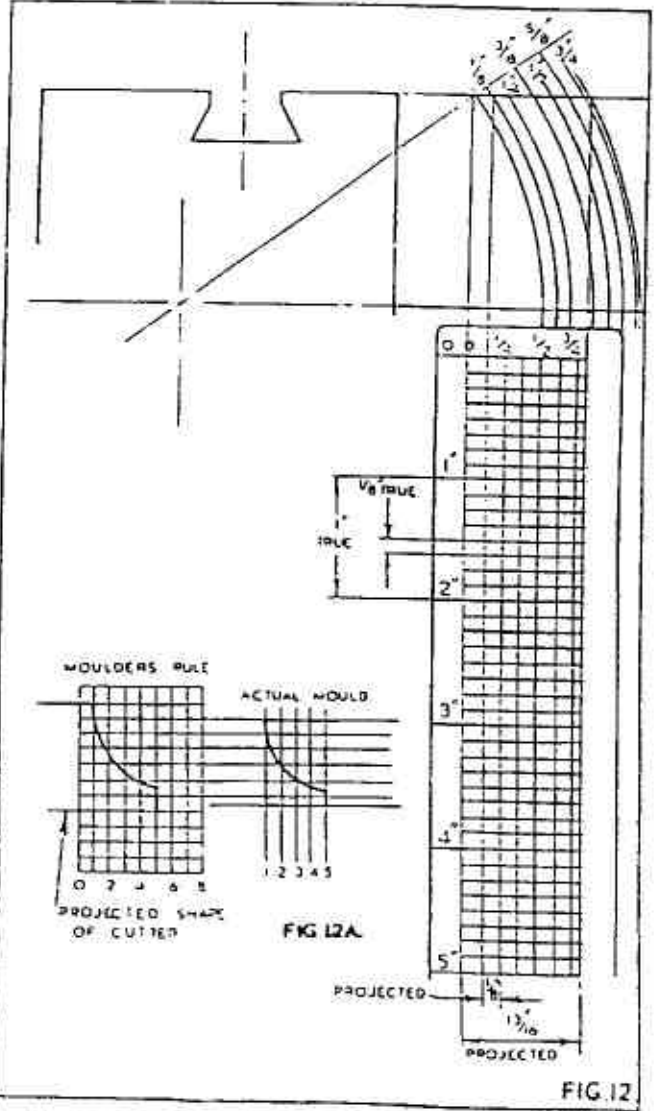

FIG. 12

To obtain the correct cutter form for a shaped mould, without using the moulders rule, it is necessary to plot this out as shown.

First the square block and cutter at minimum cutting circle are drawn out at "Y" in fig. 11. The radius of the minimum cutting circle is drawn around to the centre line and divided up by the lines A, B, C, D and E, into either 1/16" (2mm) or 1/8" (3mm) according to the size and intricacy of the shape, these lines are then struck round from the centre line radially to the face of the cutter.

At "X" the lines A1, B1, C1, D1, and E1 are carried across as shown, also at "W" the mould is produced exactly as at "Z" and divided up the same, the lines 1, 2, 3, 4 and 5 which are from the points where lines A, B, C, etc. intersect the edge of the mould, are then drawn across to "X" thus E1 is cut by 1; D1 by 2, etc. The points of intersection are joined as shown thus giving the correct projected form of the cutter.

This takes up considerable time to do for each shape of cutters required, and can be very much reduced by using the moulder's rule as shown in fig. 12. This is a graph on which the form can be plotted and automatically gives the necessary allowance on the depth of form.

When the mould is to be a standard, a template should be made to the projected form to which the cutters can be shaped when the job repeats. This will ensure uniformity on all future runs.

**MOULDERS RULE**

A permanent moulder's rule can be made by the customer in sheet brass and aluminium and will then be handy for use in the workshop.

To plot the form of a cutter by use of the moulder's rule it is necessary to draw the full size shape of the mould on tracing paper and rule 1/8" (3mm) squares as shown in fig. 12a. This is then placed alongside the moulder's rule and projected across, this will give a series of dots which must be joined to give the form of the cutter. The cutter blank chosen must be wide enough to give at least 1/8" (3mm) overlap beyond the edge of the mould. The depth of form of the cutter for the same mould varies slightly when used on a 3 1/2" (89mm) or 2 1/2" (64mm) square cutterblock due to the different cutting diameters. Moulder's rules are required for each size of square block. The cutters are not interchangeable from one size of square block to another if a really accurate mould is required.