

20" B.S.W

Wadkin AGENCIES



T: 0116 2769111
F: 0116 2598138

CIRCULAR SAWBENCH TYPE 20"BSW

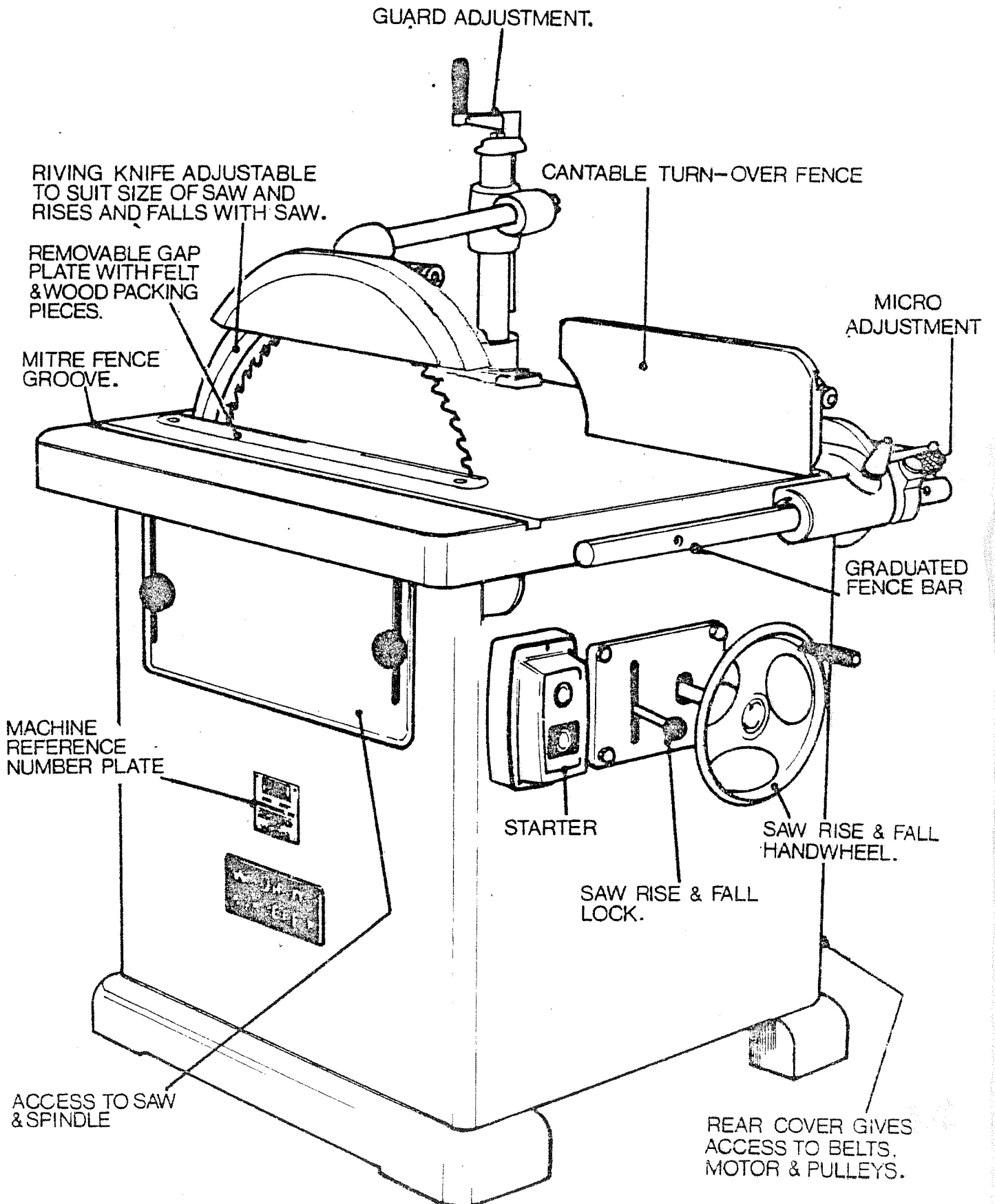

SECTIONS

SECTION A	SPECIFICATION
SECTION B	INSTALLATION
SECTION C	DESCRIPTION & OPERATION
SECTION D	MAINTENANCE
SECTION E	SPARE PARTS LIST

ILLUSTRATIONS

SECTION A	FIG A1	500mm BSW CIRCULAR SAWBENCH
SECTION B	FIG B1	WIRING DIAGRAM (3 PHASE)
	FIG B2	FOUNDATION PLAN
SECTION C	FIG C1	CANTING FENCE CONTROLS
	FIG C2	FENCE ALIGNMENT POINTS
	FIG C3	RIVING KNIFE DETAIL
	FIG C4	RISE AND FALL CONTROLS
	FIG C4A	RIVING KNIFE DETAIL
	FIG C5	MITRE FENCE
	FIG C6	MITRE FENCE STOP ROD POSITIONS
	FIG C7	SAW PACKINGS
	FIG C8-C11	OPERATION OF OPTIONAL FEATURES
	SECTION D	FIG D1
FIG D2-D3		BELT TENSIONING
FIG D4-D12		SAW MAINTENANCE
FIG D13		LUBRICATION

SECTION ASPECIFICATION

Maximum diameter of saw	20" 500 mm
Maximum saw projection	7" 175 mm
Size of table	36" x 38" 915 x 965 mm
Table height	34" 865 mm
Max. distance saw to fence	600 mm
Fence dimensions	17" x 6" 430 x 150 mm
Fence cants up to	45°
Rise and fall of saw spindle	100 mm
Speed of saw spindle	2200 rpm
Horse power of motor	7½
Diameter of saw bore	30 mm
Diameter of driving pin	12 mm
Net weight	924 lb 420 kg
Gross weight	1230 lb 560 kg
Shipping dimensions	46 cu.ft. 1.3 m ³

SECTION BInstallation:-

Remove protective anti-rust coating from bright parts by applying a cloth soaked in paraffin or other solvent.

Wiring:-

The motor and control gear have been wired in before despatch, therefore all that is required to be done is to connect the mains supply to the starter, or isolator where fitted.

POINTS TO NOTE WHEN CONNECTING TO POWER SUPPLY.

- 1 - Check voltage, phase and frequency
- 2 - It is important that the correct cable is used to deliver the correct voltage to the starter. RUNNING ON LOW VOLTAGE WILL DAMAGE MOTOR. (SEE LIST).
- 3 - Check main line fuses are of correct capacity.
- 4 - Connect line leads to correct terminals (SEE WIRING DIAGRAM).
- 5 - Check all connections are sound.
- 6 - Check spindle rotates in correct direction. If not reverse any two of the line lead connections.

FAILURE TO START:-

- 1 - Fuses have blown or have not been fitted.
- 2 - Isolator switch has not been closed.
- 3 - Lock off or stop button (when fitted) has not been released.
- 4 - Supply not available at machine.

STOPPAGE DURING OPERATION & FAILURE TO RESTART:-

- 1 - Overloads have tripped. If hand re-set, set by pressing button. If automatic they will re-set after a short period.
- 2 - Fuses have blown.

<u>VOLTAGE.</u>	<u>PHASE.</u>	<u>CYCLES</u>	<u>HP</u>	<u>S.W.G. TINNED COPPER WIRE.</u>	<u>AMPS</u>
220	3	50	5.5	17	55
340/420	3	50	"	20	32
200/250	1	50	"	14	102
220	3	60	"	17	55
400/550	3	60	"	21	29

Foundation:-

The machine should be levelled and bolted down firmly. For mounting into concrete, 150 to 250 square holes should be cut in the floor and rag bolts fitted, after which the holes should be run with cement. For mounting on wood floors coach bolts will be found adequate. (see Fig. B2.)

BROOK RT3 STARTER (THREE PHASE DIAGRAM)

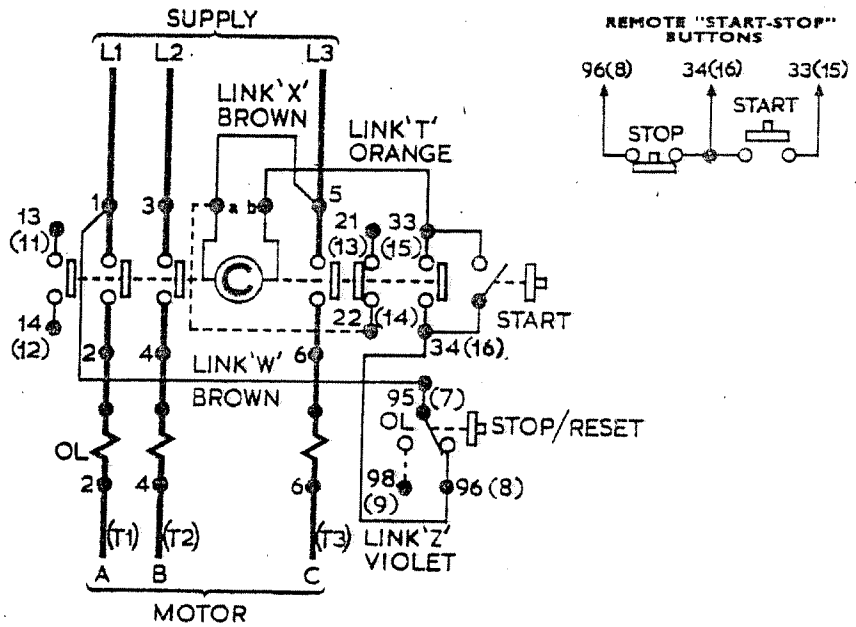

FOR ANY OTHER TYPE OF STARTING SEE SEPARATE WIRING DIAGRAM ENCLOSED INSIDE STARTER BOX.

FIG B1

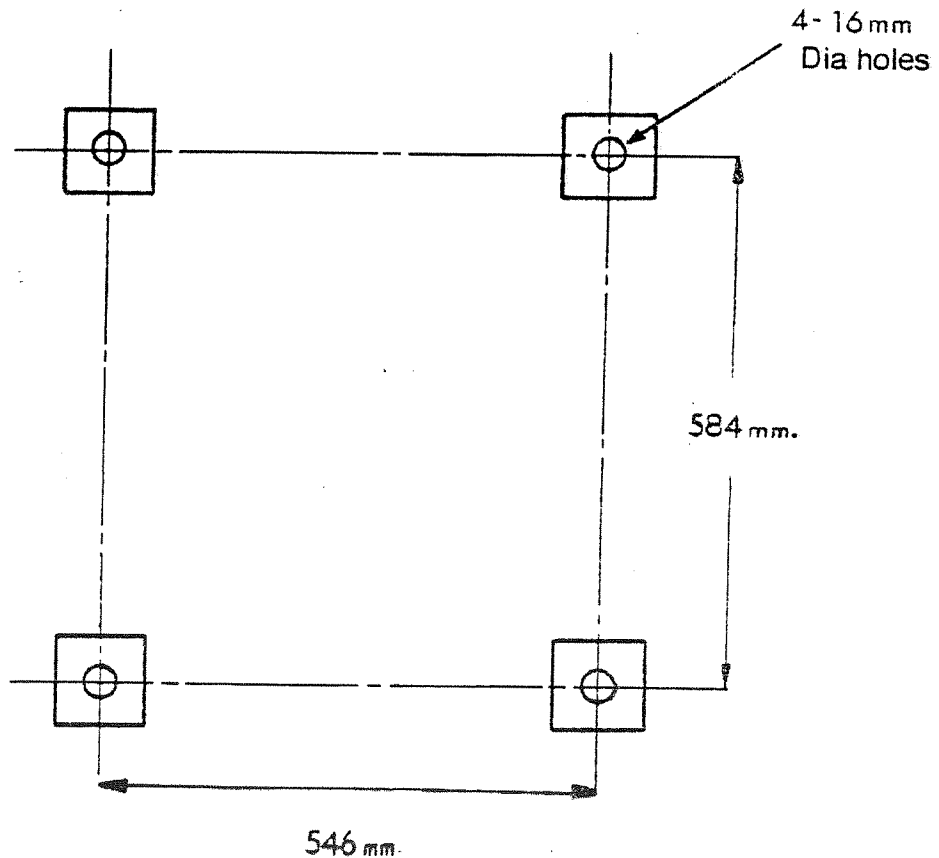

FIG B2

SECTION CCANTING & RIP FENCE CONTROLSQUICK ADJUSTMENT:-

The fence slides on a round bar with a rule incorporated into it. To adjust the fence follow the under mentioned procedure:-

1. Unlock lever 'A' and screw 'B' (Fig.C.1.)
2. Slide the fence along the bar until the required dimension is indicated against the pointer on the fence bracket.
3. Lock lever 'A' firmly to secure in position.

FINE ADJUSTMENT:-

After adjusting the fence by the above method provision is made for precise setting by operating the fine adjustment feature. To operate follow under mentioned procedure.

1. Ensure lever 'A' is UNLOCKED and screw 'B' is LOCKED firmly. (Fig.C.1.)
2. Turn knurled hand screw 'C' in direction required in order to draw the fence along the rule bar to or away from the saw and to the required setting.
3. Lock lever 'A' firmly.

CANTING:-

To cant fence follow under mentioned procedure (Fig.C.1.)

1. Unlock lever 'D' and allow fence to pivot over to required angle.
2. Unlock lever 'E' allowing fence plate to drop down until the lower edge of the plate lies flat on the table surface.
3. Lock levers 'D' and 'E' firmly.

FENCE POSITIONING:-

The fence plate is designed to slide along the table in order to compensate for different sizes of saws which may be used. By unlocking lever 'E' the plate may be slid along dovetail slot in the back of the fence to the required position, after which locking lever 'E' will fix the fence firmly in place.

NOTE:- For crosscutting swing fence over the rule bar to clear the table

FENCE SETTING AND ALIGNING:-

On despatch from the works the movements of the fence have been finely adjusted for accurate cutting by the provision of the setting screws at points F.G.H.I. (FIG C2). These adjustments have separate uses, and should only be re-set to compensate for wear which may take place from constant use. The separate uses of these points are as outlined underneath:-

POINT F:- is an eccentrically turned centre which allows the fence to be set parallel to the saw, or to be set in or out as required.

POINT G:- is a true centre which allows slackness to be removed between centres F and G.

POINT H:- is a jacking point which provides a positive stop which will not allow the fence to be pulled up further than 90 degrees to the table when set correctly.

POINT I:- is also a jacking point which brings centres F and G parallel to the table for true canting action of the fence.

NOTE:- SET ALIGNMENT ONLY WITH CENTRE F. DO NOT PACK BETWEEN BACK PLATE AND FENCE AS THIS CAN CRACK THE CASTINGS.

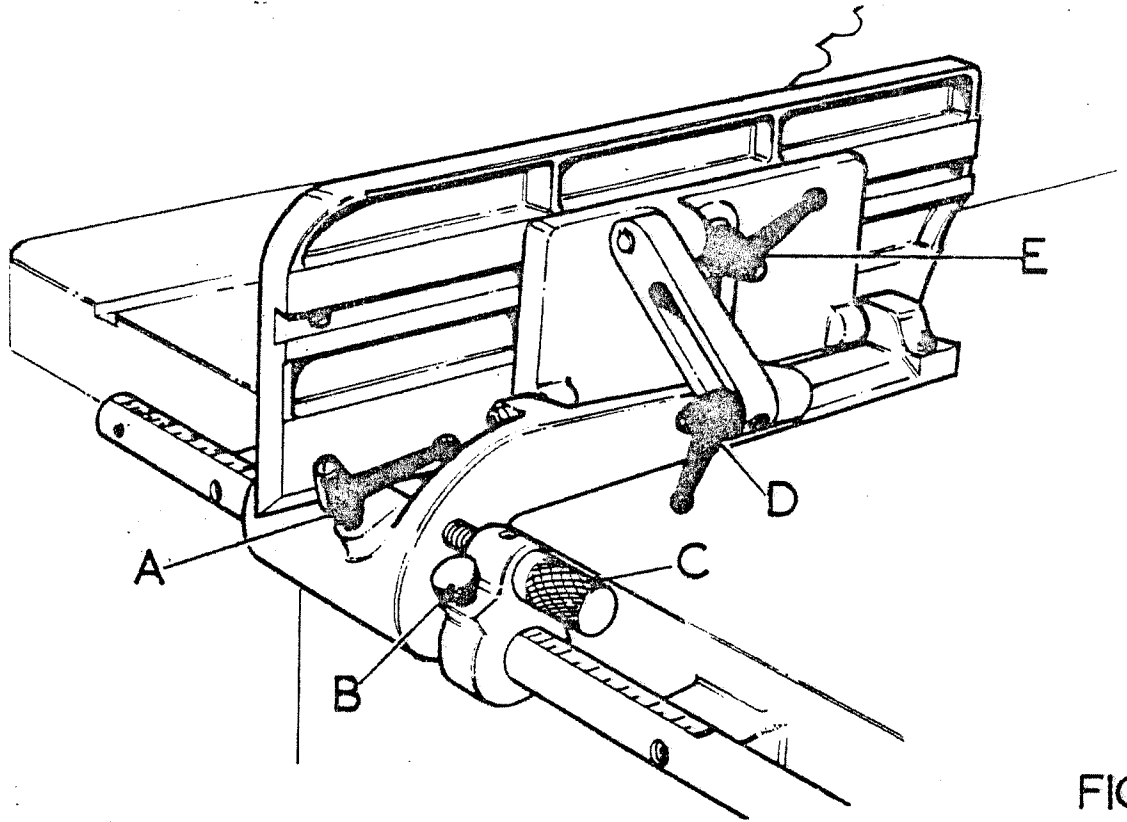
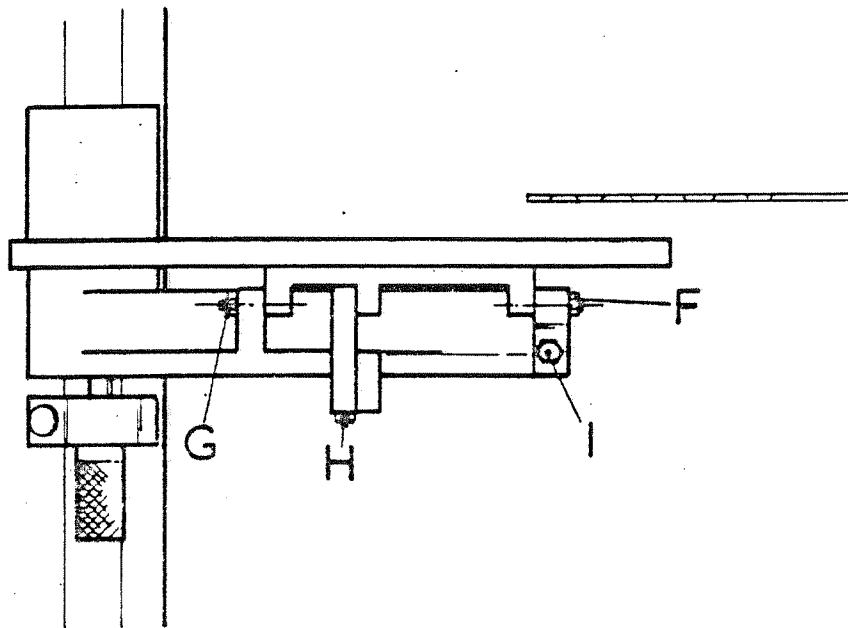

FIG.C1



FIGC2

RISE AND FALL CONTROLS:-

By turning handwheel 'J' (fig. C4) the saw may be raised or lowered between the maximum and minimum position as given in section 'A' specification. Under no circumstances should this dimension be varied. It is important after operating the rise and fall that lever handle 'K' is locked firmly before running the saw.

The rise and fall handwheel is connected through pivoted yolks at points A. & B. (FIG C4.) At the handwheel end of the screw a thrust race C is fitted to give free rotation when in use. It is therefore important that the pivots and screw are cleaned and lubricated regularly and that the thrust race is oiled according to the maintenance schedule.

RIVING KNIFE PLATE:-

The riving knife plate is situated behind the saw in the saw compartment 'D' (fig. C4A) and allows the riving knife to rise and fall with the saw at a set clearance to the saw teeth. It is important that the area surrounding the radial slot cut in the plate be kept clean and well lubricated to give free movement.

RIVING KNIFE HOLDER DETAIL

The riving knife is supplied in the inverted position. Remove and fit upright adopting the following procedure:- (fig C3)

1. Fit knife into grooved packing piece 'E' and bolt up to solid packing piece 'F' with the 10mm nuts 'G' provided.
2. With saw in place set knife to clear around saw teeth approximately $\frac{1}{4}$ " (6mm) and lock firmly in place with nuts 'G'.
3. If the knife is not in line with the saw, partially slacken nuts 'G' and jack packing piece 'F' out with grub screws 'H' until the knife has equal overhand either side of the saw blade. Lock nuts 'G' firmly.

NOTE:- BEFORE RUNNING, ADJUST SAW GUARD TO GIVE MAXIMUM PROTECTION AND TO CLEAR SAW BLADE. DO NOT RUN MACHINE WITHOUT GUARD IN POSITION.

IMPORTANT:- ENSURE THAT RIVING KNIFE BLADE IS CORRECT THICKNESS FOR SAW USED

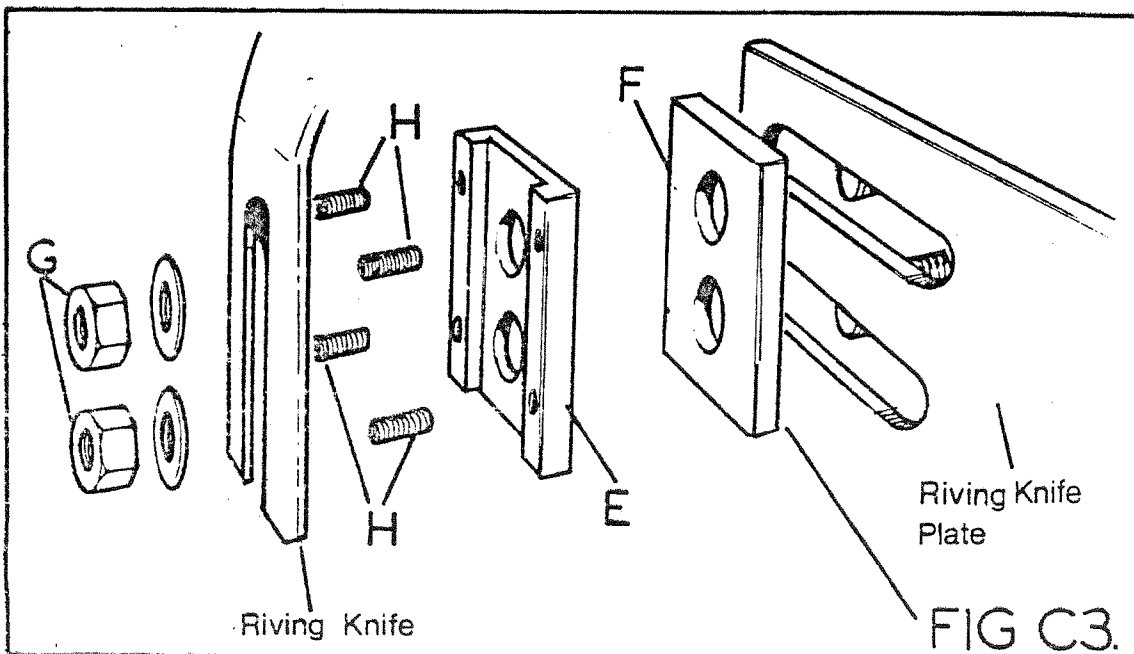

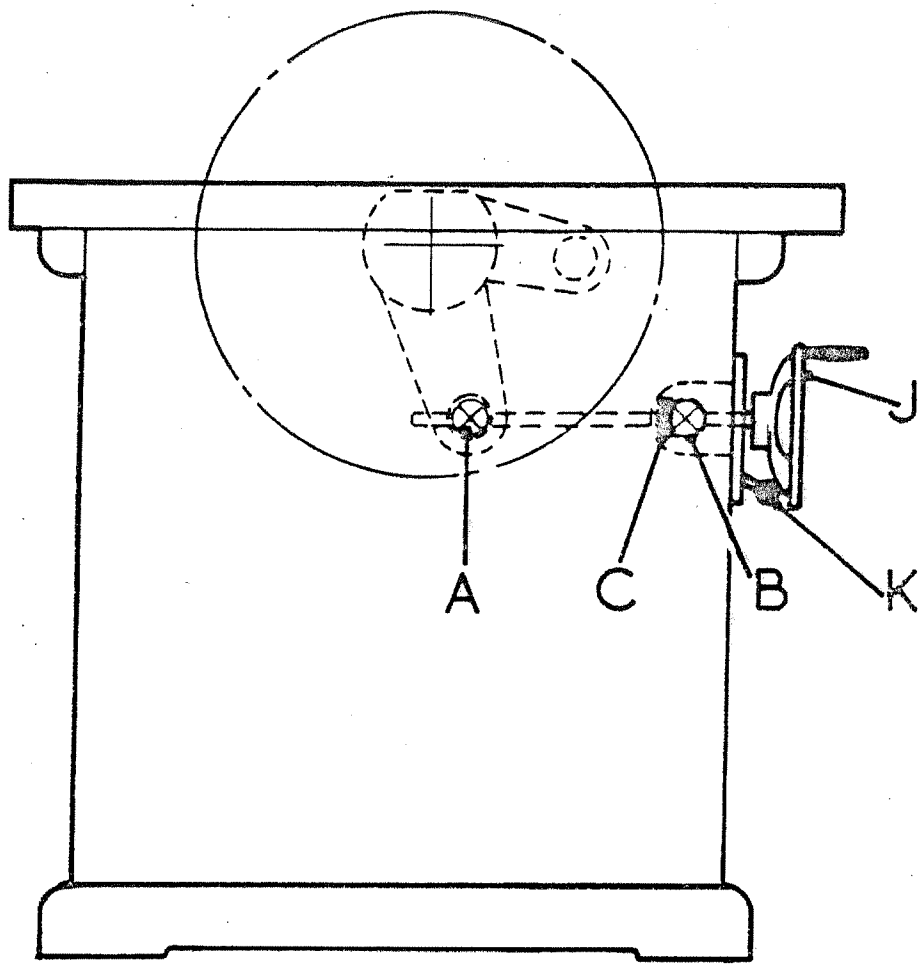
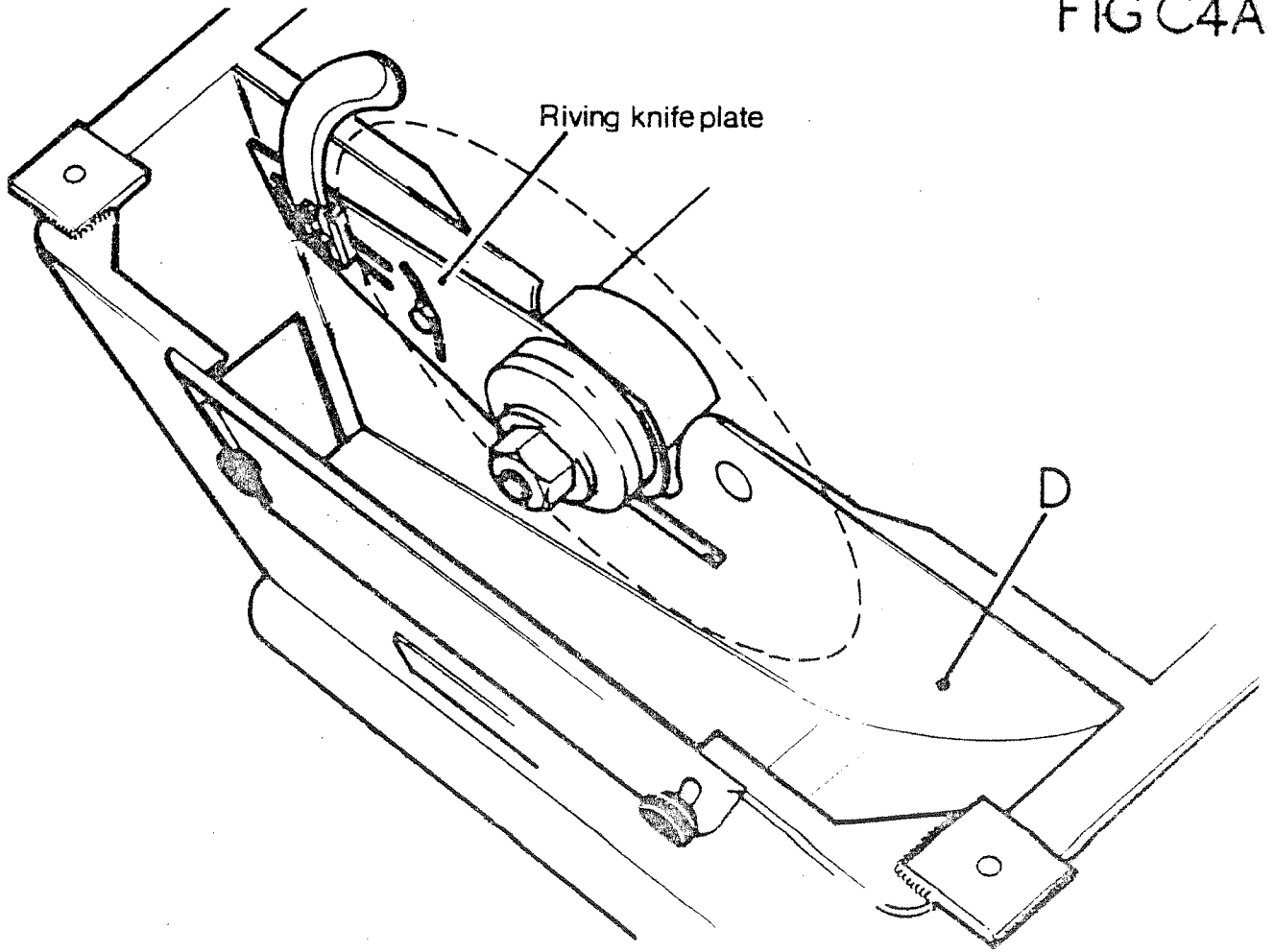

FIG C4

FIG C4A



MOUNTING SAWBLADES:-

When mounting saws the undermentioned procedure should be followed:-

1. Isolate machine
2. Remove table insert and raise the saw spindle housing into the top position.
3. Remove spindle nut (left hand thread) and front saw flange from spindle.
4. Select blade required depending on type of work which is to be done. Check the blade is in good condition and free from dirt, sawdust and gum, especially where it will be gripped by the saw flange. Mount saw on the spindle checking that the face of the back saw flange is clean and that the saw bore and pin hole centres fit correctly onto those on the flange.
5. Check that the saw teeth point towards the front of the machine before replacing the flange and locking up firmly with the spindle nut.

IMPORTANT:- ENSURE SPINDLE RUNS IN CORRECT DIRECTION, REFER TO SECTION B (ELECTRICS)

NOTE:- IF THE FLANGE OR SAW FACES ARE NOT CLEAN THIS CAN CAUSE VIBRATION DUE TO THE SAW RUNNING OUT-OF-TRUE,

MITRE FENCE (fig. C5) (EXTRA.)

The mitre fence is fitted into the groove provided on the saw table, which should be kept clean. A scale is provided to indicate accurate setting, and a positive stop 'A' is incorporated in the scale to give quick setting at 90° and 45° to the saw. The plastic handwheel 'B' locks the mitre fence firmly in any position.

Accurate repetitive cutting can be obtained by use of the stop rods (fig. C5.)

The rods are held in the fence with the thumbscrews 'C' and the stop rods by the two clamps 'D'. To adjust the stop rods slacken clamps 'C' and 'D' and slide the rods into the position required as illustrated in (fig. C6.)

FIGC5

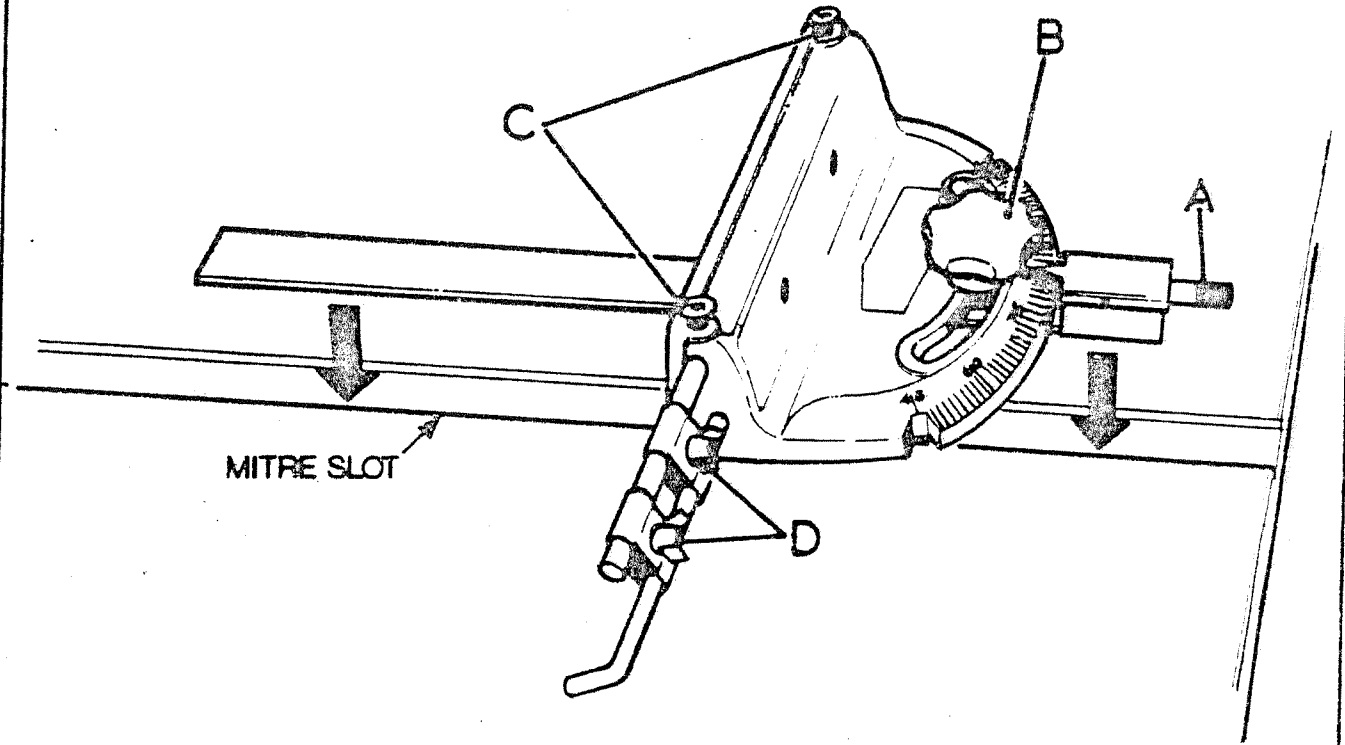

FIGC6

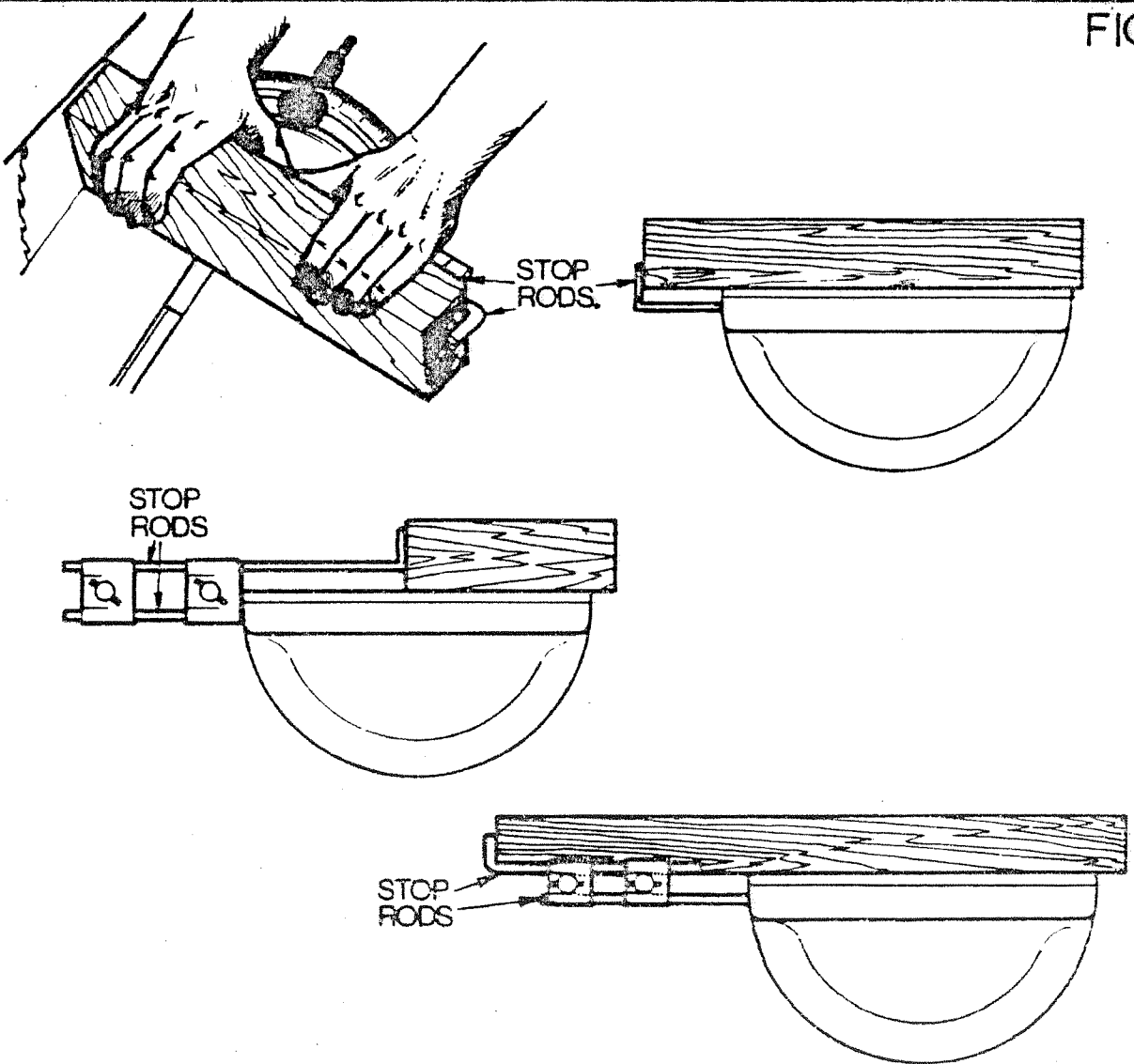

SAW PACKING.

It is usual to provide a saw blade with some form of packing, but it is not intended that this packing be used as a guide for buckled or out-of-true saws. The idea of fitting packing pieces into the table and gap plate is to steady the saw, but it should be noted that the packing must not be tight as this will generate heat, resulting in a consequent loss of tension in the blade.

The arrangement of the saw packings are in such a way that a hardwood mouthpiece of a length extending beyond the depth of the saw teeth retains the felt packing pieces in place. Also wood strips secured to the underside of the table and to the front of the gap plate support the felt in position. At the rear of the gap plate and table similar wood strips close the saw gap and provide a guide for the saw. (SEE DIAGRAMS OPPOSITE.)

It should be noted that after some time, the packings will need to be renewed, and should not be allowed to fall into bad condition.

The provision of the felt inserts allow application of a small amount of lubricating oil, which not only cleans the saw, but also reduces heat and burning whilst running. It is therefore important that, at every opportunity, the felt pieces are lubricated.

NOTE:- REPLACEMENT LENGTHS OF FELT 12 x 11 x 100 mm

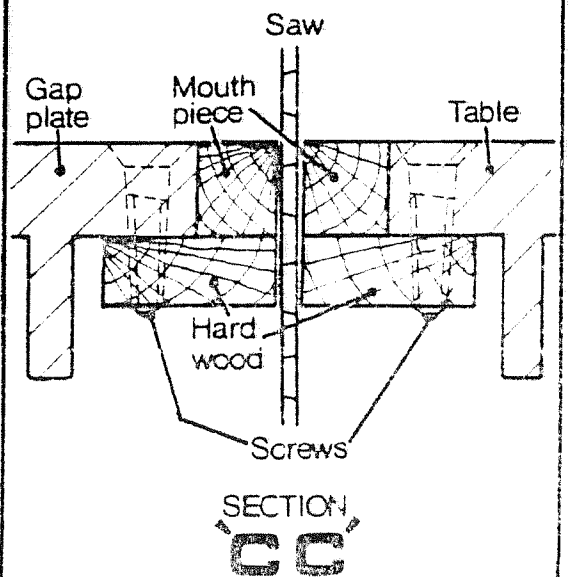
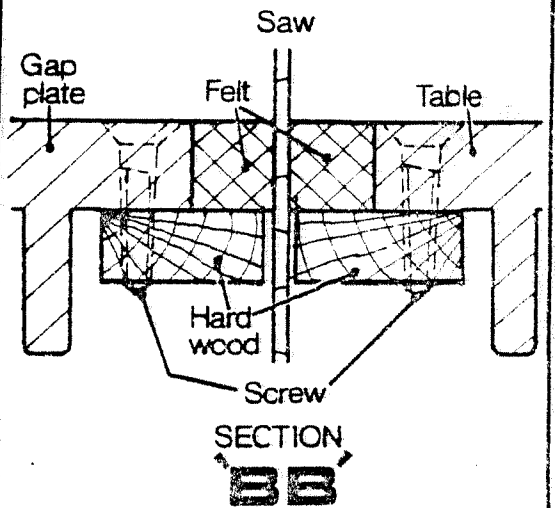
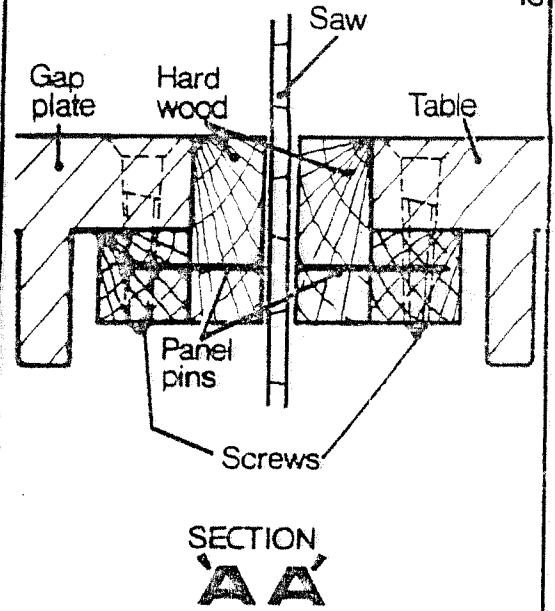
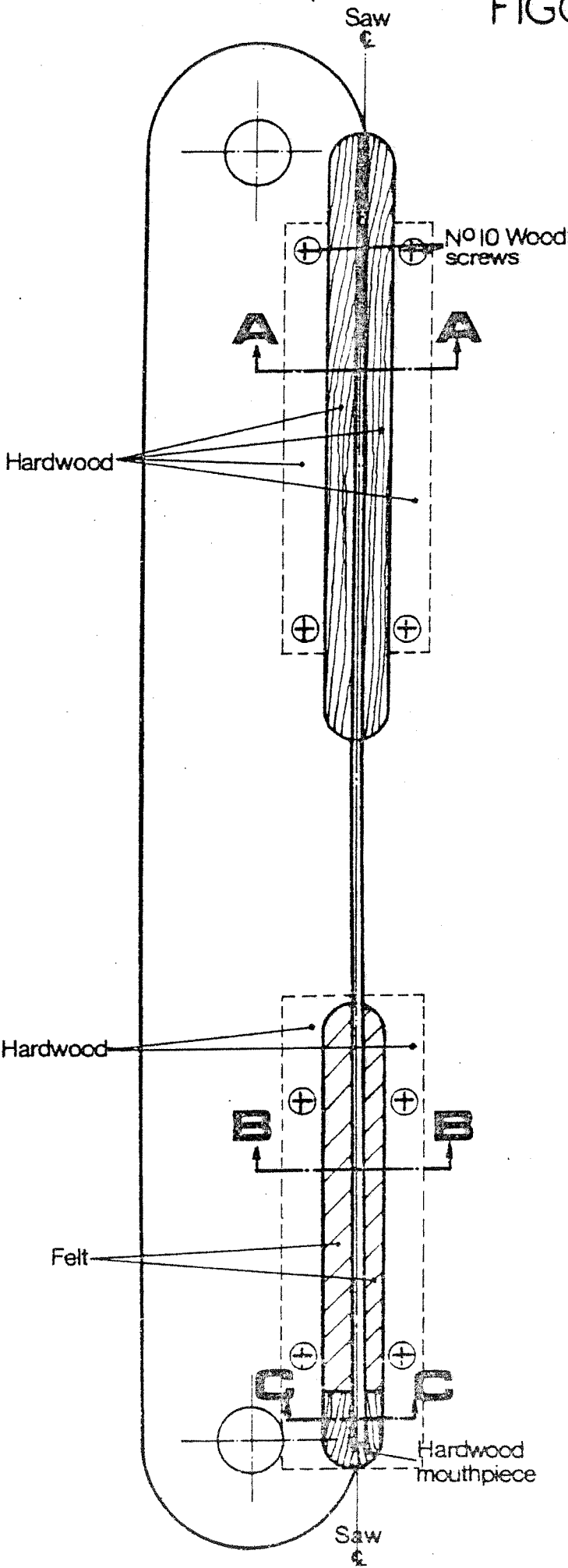

PILLAR SAW GUARD

To raise and lower the guard, unlock lever 'A' and turn handle 'B' (FIG C8). To position the guard on centre with the saw, unlock lever 'C' and slide the guard pillar 'D' until the guard is in the correct position. To centralize the guard to clear saw and riving knife, unlock lever 'E' and slide guard back or forward along bar 'F' until correctly positioned.

To gain access to saw, the guard cover will hinge up and over to reveal blade.

EXTRA EQUIPMENT:-

SPINDLE BRAKE:- This device is operated from the brake lever 'A' situated next to the rise and fall handwheel. It is connected to the brake pad by means of a cable 'B' leading from the operating lever, and is spring-loaded to relieve tension when hand pressure is relieved. To tension the cable, turn the knurled nut 'C' on the lever. Where excessive slackness is to be removed, unlock the grub screw 'D' on the pillar at the spindle end and pull cable through, re-lock grub screw and tension cable as mentioned above with knurled screw. When replacing brake pad it is important that new rivets are used and that the rivet heads are below the surface of the pad material. Do not allow brake pad to wear down to rivets as this will score the surface of the special pulley.(FIG C11)

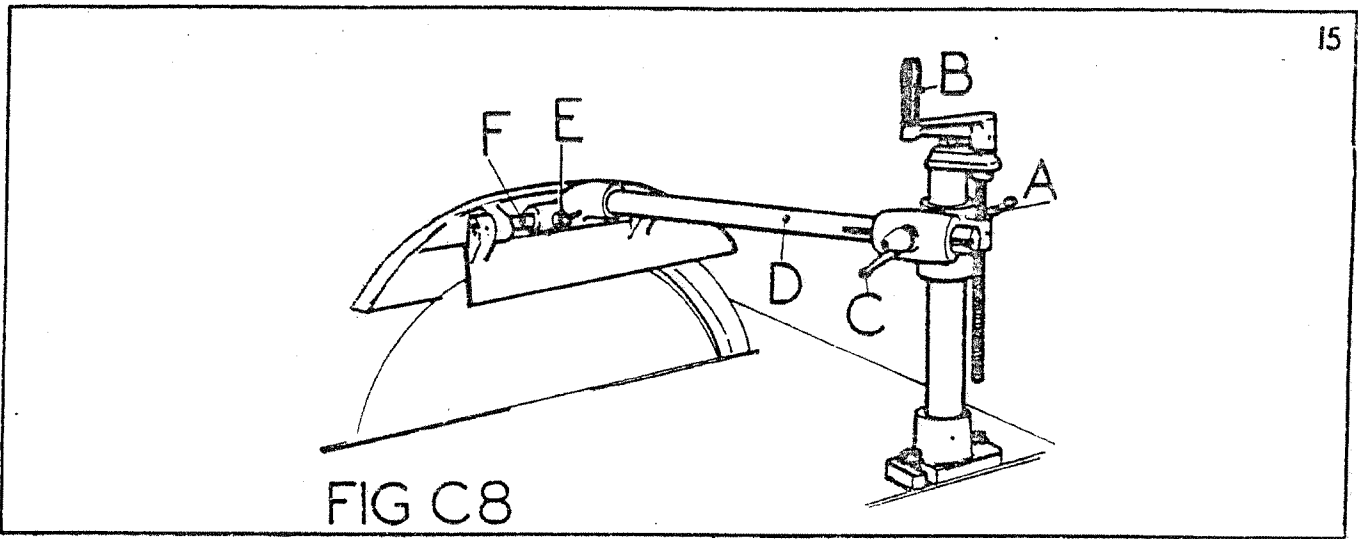

FIG C8

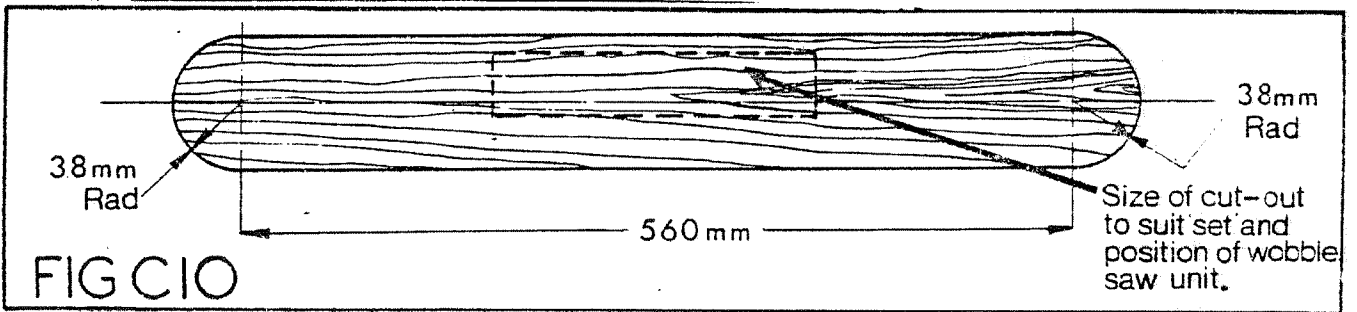

FIG C10

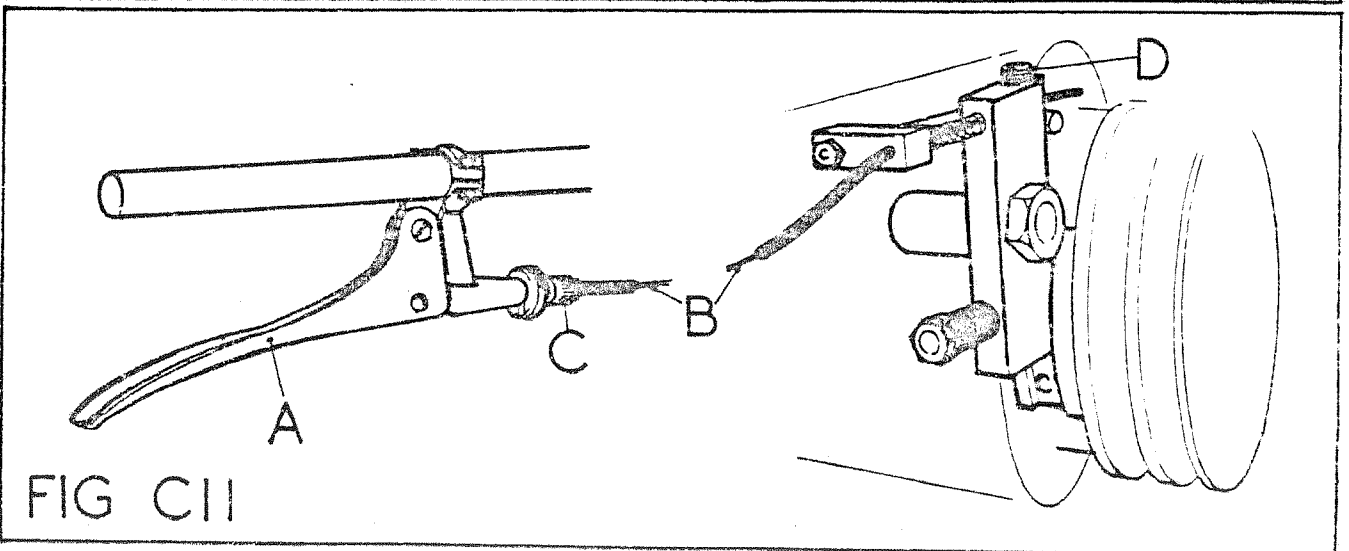

FIG C11

SECTION D. - MAINTENANCE:-

During the operating life of the sawbench it may be found necessary to replace worn or damaged parts (i.e. ball races.) To undertake this procedure follow the undermentioned instructions. (SEE FIG D 1.)

1. ISOLATE MACHINE ELECTRICALLY BEFORE ATTEMPTING ANY WORK.
2. REMOVE GAP PLATE, SAW AND SAW SPINDLE FRONT AND REAR COVERS FROM THE MACHINE.
3. SLACKEN AND REMOVE V-ROPES FROM PULLEYS AND REMOVE TURNBUCKLE AND TENSION STUDS AFTER PACKING MOTOR UP AS SHOWN IN (FIG D.2.)
4. WIND SAW CARRIAGE INTO MIDWAY POSITION.
5. REMOVE COUNTERSUNK SCREW AND WASHER 'A' AND SLACKEN GRUB SCREWS 'B' IN PULLEY 'C' AND REMOVE.
6. REMOVE KEY 'D' AND DISTANCE PIECE 'E'.
7. REMOVE CIRCLIP 'F' AND MOTOR TENSION BRACKET 'G' AND UNSCREW AND REMOVE DUSTCAP 'H'.
8. WORKING AT THE FRONT OF THE SAW SPINDLE, REMOVE NUT 'I' (L.H.THREAD) AND SAW FLANGE 'J'.
9. UNSCREW SAW FLANGE 'K' (L.H.THREAD.)
10. REMOVE RIVING KNIFE PLATE* AND LINK, AND UNSCREW AND REMOVE DUST CAP 'L'.
11. PLACE A WOODEN DRIFT ON THE PULLEY END OF THE SPINDLE AND DRIVE THE SHAFT THROUGH THE HOUSING. BY DOING THIS THE SPINDLE WILL EMERGE FROM THE HOUSING WITH THE SAW END BEARING ON IT. DRIVE THIS BEARING FROM THE SHAFT AND RE-INSERT SHAFT INTO HOUSING KNOCKING SPINDLE THROUGH WITH HAMMER AND DRIFT TO REMOVE THE PULLEY END BEARING.

To re-assemble, reverse above procedure ensuring all original parts are thoroughly cleaned out.

* It should also be noted that the two locknuts on the radial slot in the riving knife plate should only be tightened enough to provide a guide for the motion of the plate and not to clamp or lock the plate in position.

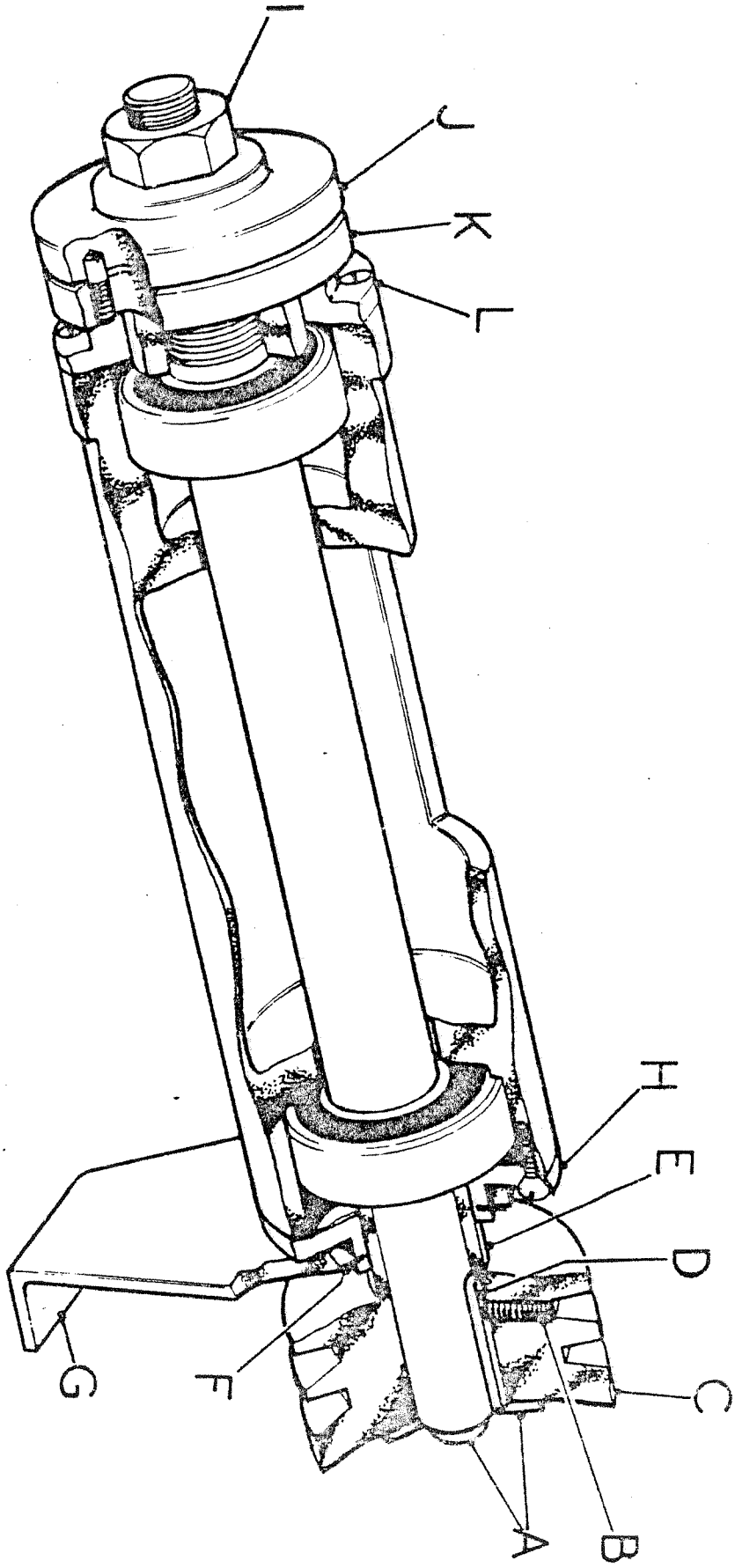

FIG D1

BELT TENSION:-

On the standard machine the drive from the 5.5HP motor (4KW) to the saw spindle is by means of three ALPHA 500 type "V" Belts. To ensure maximum efficiency and life of these belts, it is important that the correct belt tension is maintained at all times from new, especially in the "running in" period. To tension the belts follow the undermentioned procedure. (SEE FIG. D.2.)

By turning turnbuckle 'A' linking the tension studs, the centre distance of the pulleys can be increased to provide greater tension on the belts. To achieve the correct tension, measure the centre distance of the pulleys (FIG D3.) and adjust with the turnbuckle until, whilst applying a force at right angles and central along the belt, the deflection is not greater than 0.5mm per 25mm of span - (e.g. 584 span = 11.5mm deflection.)

REPLACING BELTS:-

To replace belts, decrease pulley centre distance by screwing turnbuckle and thus relieving tension on the belts for their removal. Afterwards retension as given above.

POINTS TO NOTE WHEN MAINTAINING BELT DRIVES:-

1. ALWAYS MAINTAIN CORRECT BELT TENSION.
2. REPLACE WORN BELTS WITH SAME TYPE AS SPECIFIED.
3. ALWAYS REPLACE WORN OR DAMAGED BELTS IMMEDIATELY.
4. ENSURE PULLEYS ARE CORRECTLY ALIGNED.
5. DO NOT PRISE BELTS OVER PULLEYS WITH SCREW DRIVERS OR OTHER SHARP IMPLEMENTS AS THIS CAN DAMAGE BELTS.
6. ENSURE PULLEY GROOVES AND BELTS ARE CLEAN AND REMOVE ANY OIL, GREASE RUST OR BURRS WHICH ARE PRESENT.

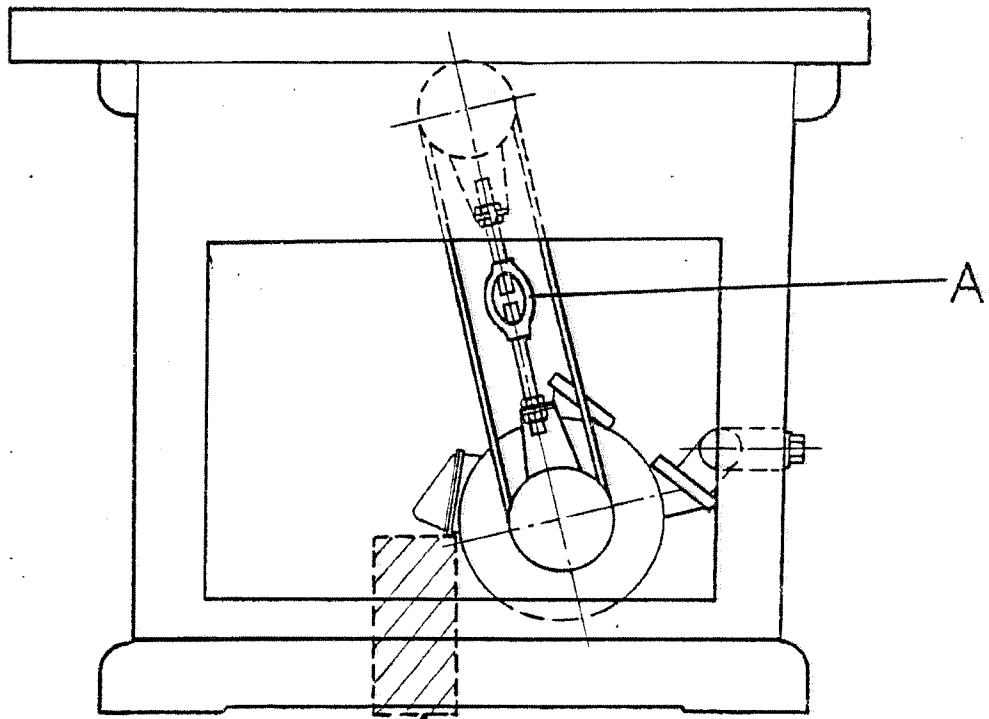

Method of packing up motor for removal of tension screws as outlined in section D1

FIG D2

FIG D3

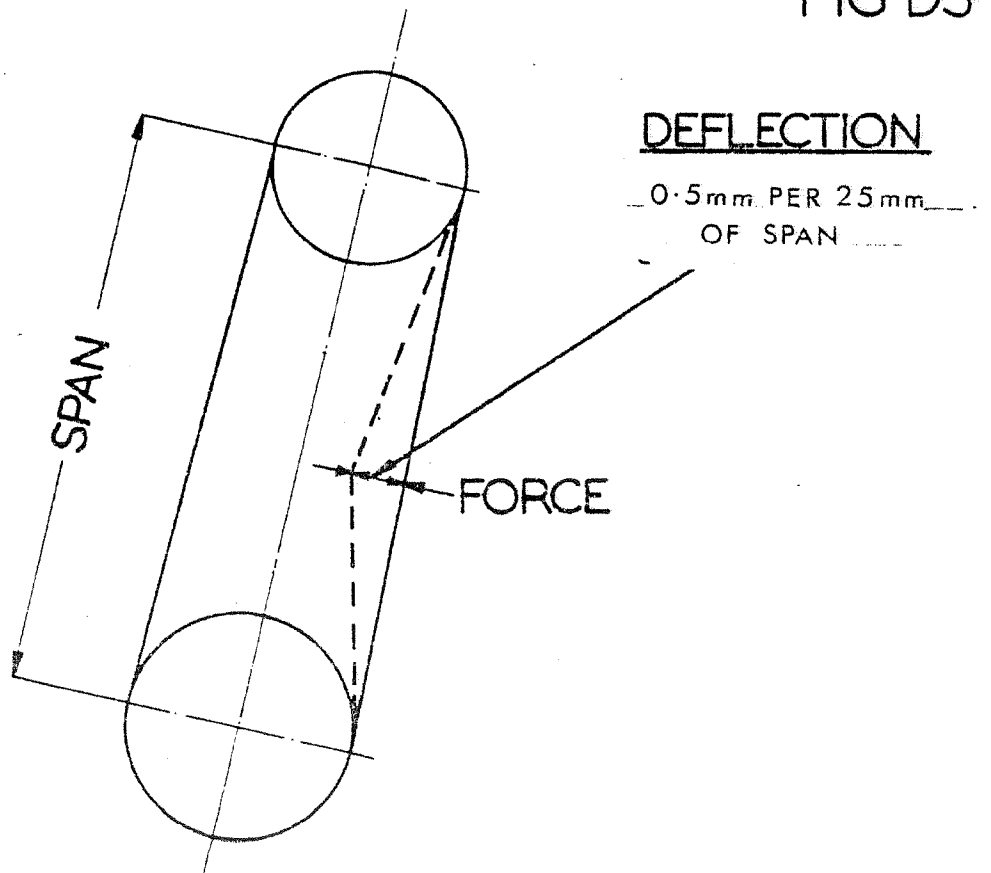

SAW MAINTENANCE:-

Efficient operation of a circular saw depends on true running of the saw spindle, and the saw flanges being perfectly square to the axis of the spindle. The saw must also run at the correct peripheral speed to ensure straight cutting.

RANGING:-

'Ranging down' should be done on a new saw or any saw after the fourth or fifth sharpening. To range down, feed a square-edged abrasive block in a wooden holder (FIG D4.) lightly against the saw teeth whilst running. The saw should then be removed and the tops of the teeth filed lightly to remove the ranging marks.

SAW SHARPENING:-

Do not run a saw when blunt. To re-sharpen by hand, hold the saw in a vice as shown in (FIG D5.) With rip saw teeth, chisel edges and square faces are required (FIG D6.) Sharpen by giving each tooth an equal number of strokes with a flat file. At the same time, file the gullet of the saw in the same manner, taking care to keep the gullet well rounded. With cross cut saws points are needed with back and front bevels as in (FIG. D7.) In the course of repeated filing, saws lose their original shape and the gullets become shallow. To restore the original profile, it is necessary to grind the saw on a saw-sharpening machine.

SETTING:-

The amount of set should be sufficient to give clearance to the saw body so there is freedom from friction. Saw teeth are generally 'spring set' (i.e.) the teeth are bent alternately to the right or left as shown in (FIG D8) For good sawing, this amount of set should be equal at each side or else the saw will run to one side. To check the set, cut into a piece of timber where the result should be a small, even triangle, as seen in (FIG. D9) The amount of set varies according to the timber being cut, but is usually, .3mm - .4mm.

We can supply a small machine for precisely setting saws as shown in (FIG D10) This device will accept saws up to 36" in diameter, and indicates the amount of set by micrometer dial.

For hand setting, small devices can be supplied where it is felt that the number of saws used does not warrant a machine (SEE FIGS.D11 & D12.)

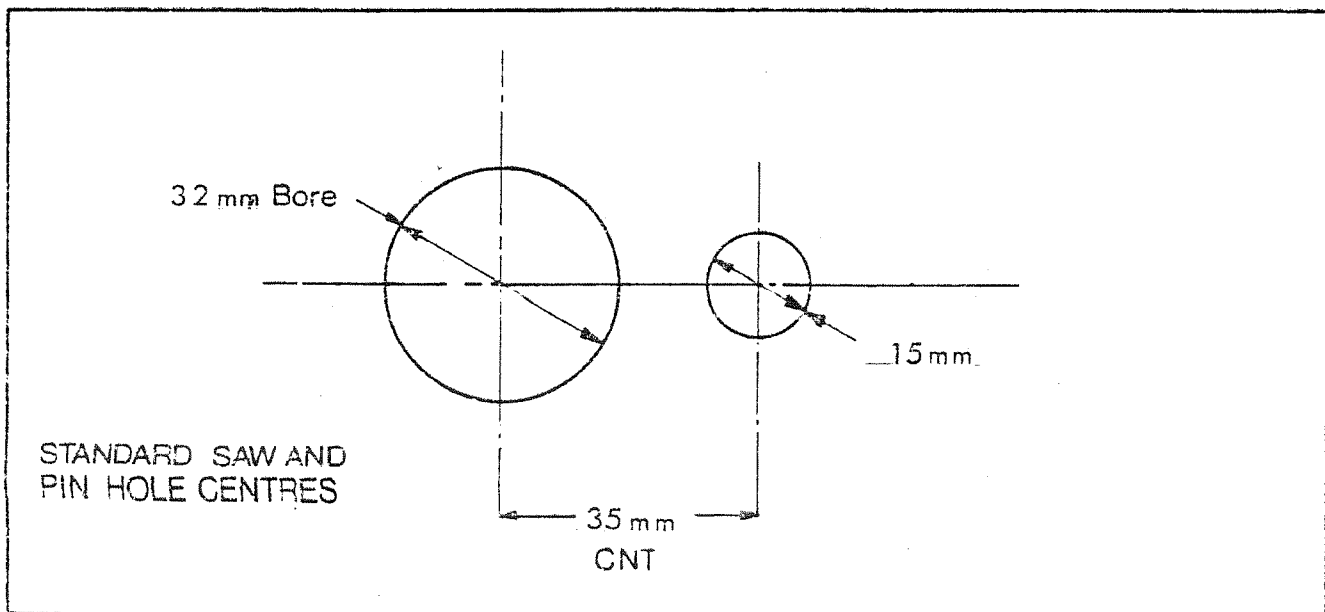

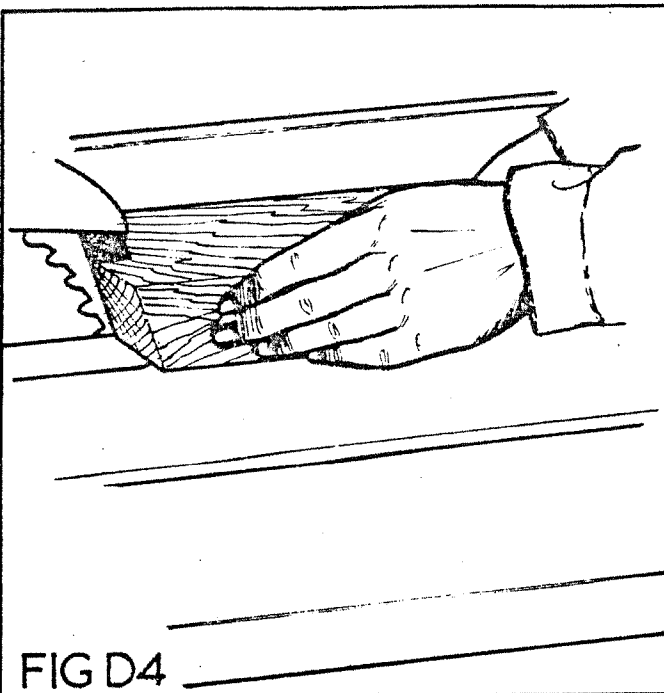

FIG D4

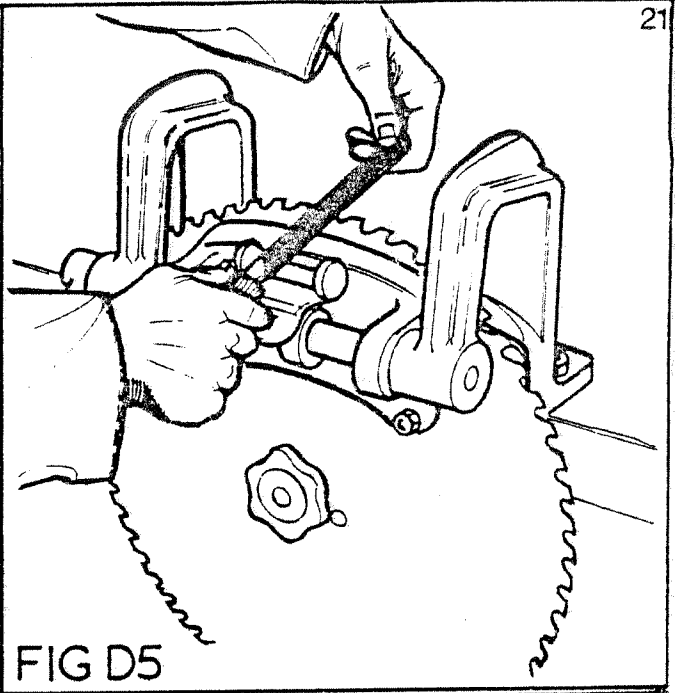

FIG D5

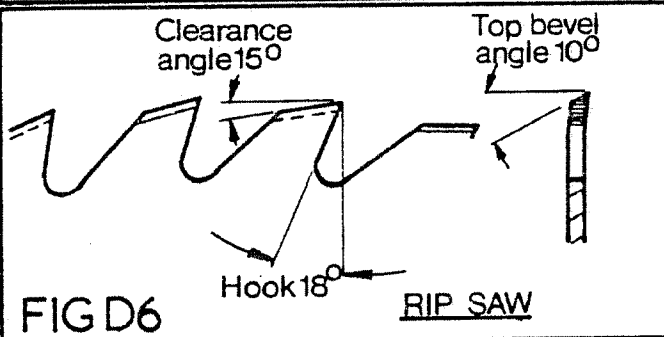

FIG D6

RIP SAW

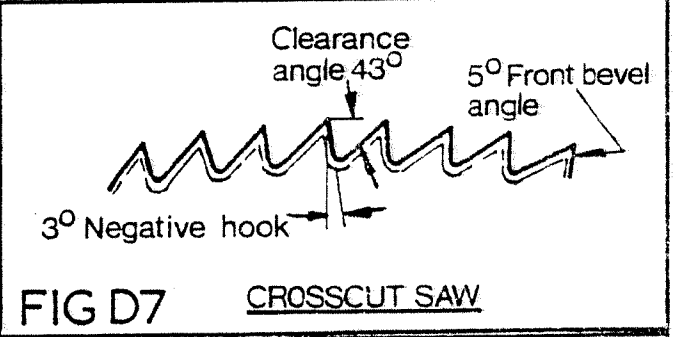

FIG D7

CROSSCUT SAW

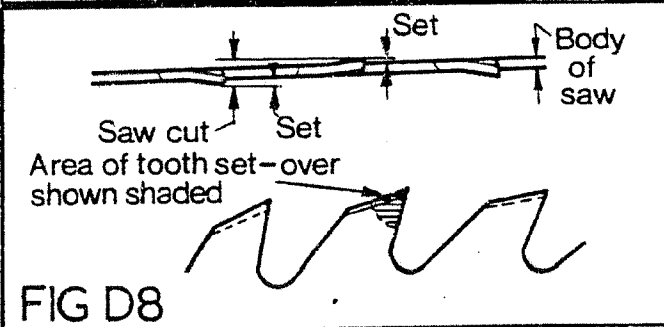

FIG D8

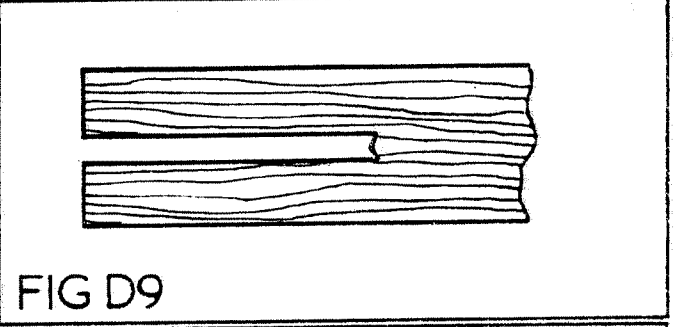

FIG D9

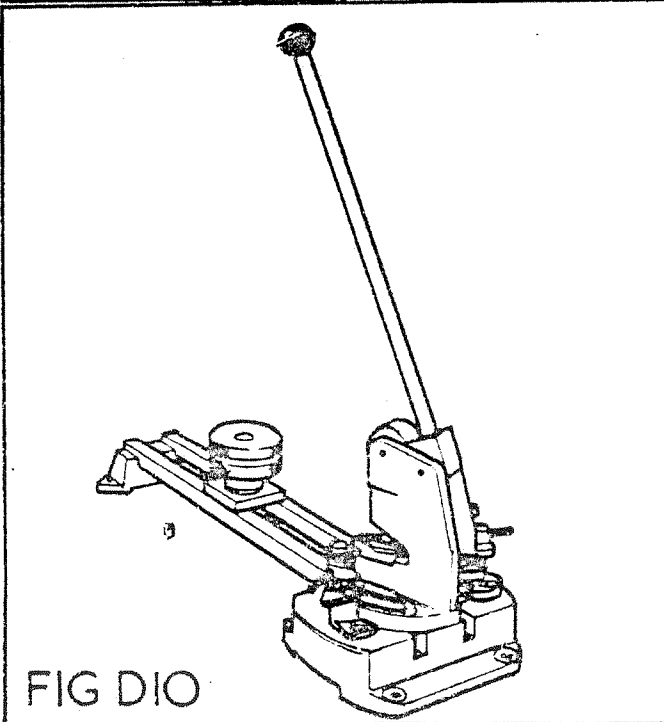

FIG D10

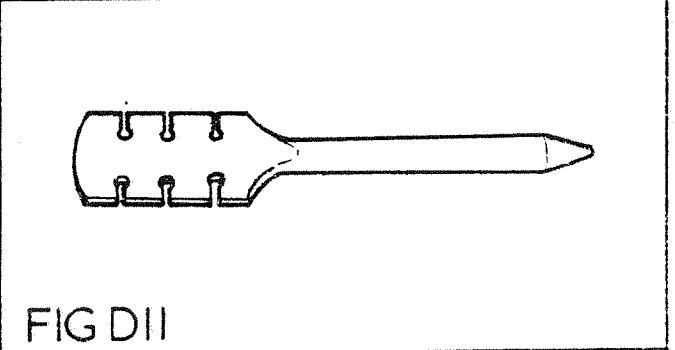

FIG D11

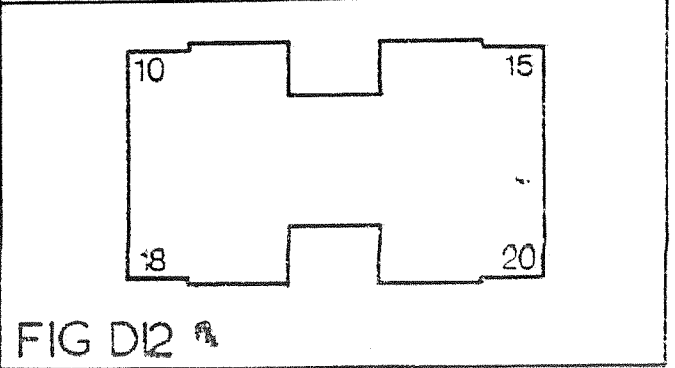
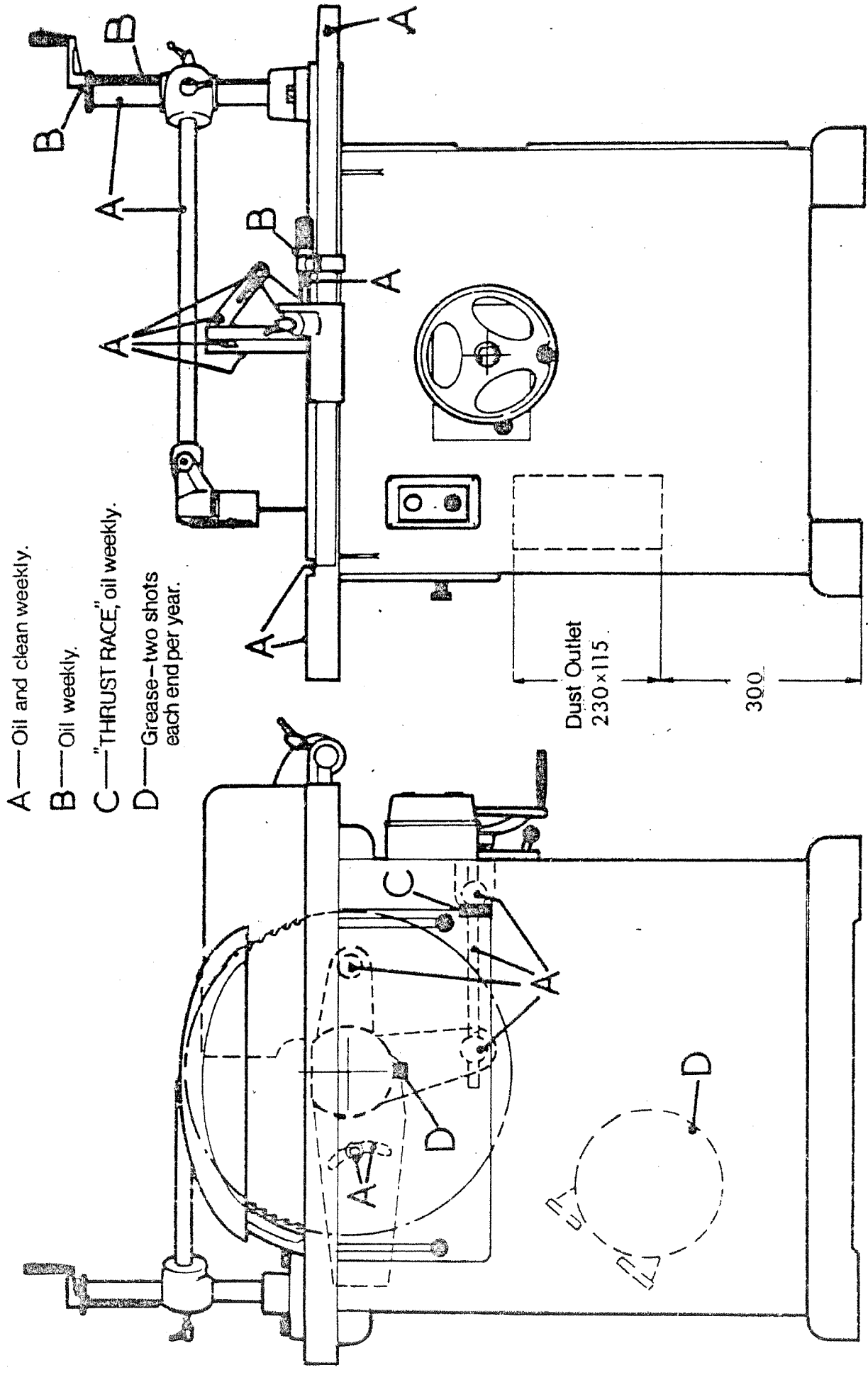

FIG D12

LUBRICATION DIAGRAM



SECTION "E"

SPARE PARTS LISTS

MAIN BASE ASSEMBLY

<u>REF.</u> <u>NO.</u>	<u>PART</u> <u>NO.</u>	<u>NO.</u> <u>OFF</u>	<u>DESCRIPTION</u>
1	BSW 1	1	MAIN BASE
2	BSW 2	1	TABLE (STANDARD)
3	BSW 3	1	GAP PLATE
4	BSX 12	1	SPINDLE PULLEY COVER
5	BSW 11	2	BASE FEET
6	BSW 137	1	FRONT COVER
7	BSW 27	1	BASE COVER
(8	- - -	1	BROOK RT 3 STARTER)
(PLEASE STATE VOLTAGE, PHASE & FREQUENCY)		
9	- - -	1	WADKIN BURGREN NAMEPLATE
10	- - -	2	REAR WOOD SAW PACKINGS
11	- - -	2	FRONT WOOD SAW PACKINGS
12	- - -	8	No. 10 WOODSCREWS
13	- - -	4	M12 x 30 mm LONG HEXAGON BOLTS
14	- - -	4	12 mm WASHERS
15	- - -	2	10 mm DIA x 25 mm LONG DOWELS
16	- - -	2	M8 x 15 mm LONG ROUND HEAD SCREWS
17	- - -	4	M10 x 35 mm LONG SCREWS
20	- - -	8	M10 x 25 mm LONG HEXAGON BOLTS
21	- - -	2	M6 x 10 mm LONG HEXAGON BOLTS
22	- - -	2	6 mm WASHERS
23	BZG 70	1	SPRING GUARD CLIP
24	- - -	2	M6 NUTS
25	- - -	2	WING NUT
26	- - -	2	10 mm EXTERNAL CIRCLIP
27	- - -	1	M8 x 15 mm LONG ROUND HEAD SCREWS
28	- - -	2	1/8" DIA BRASS RIVETS
29	- - -	3	2BA x 20 mm LONG SCREWS
30	- - -	2	DRIVEPINS

WHEN ORDERING SPARE PARTS PLEASE QUOTE PART NUMBER AND SERIAL NUMBER OF MACHINE

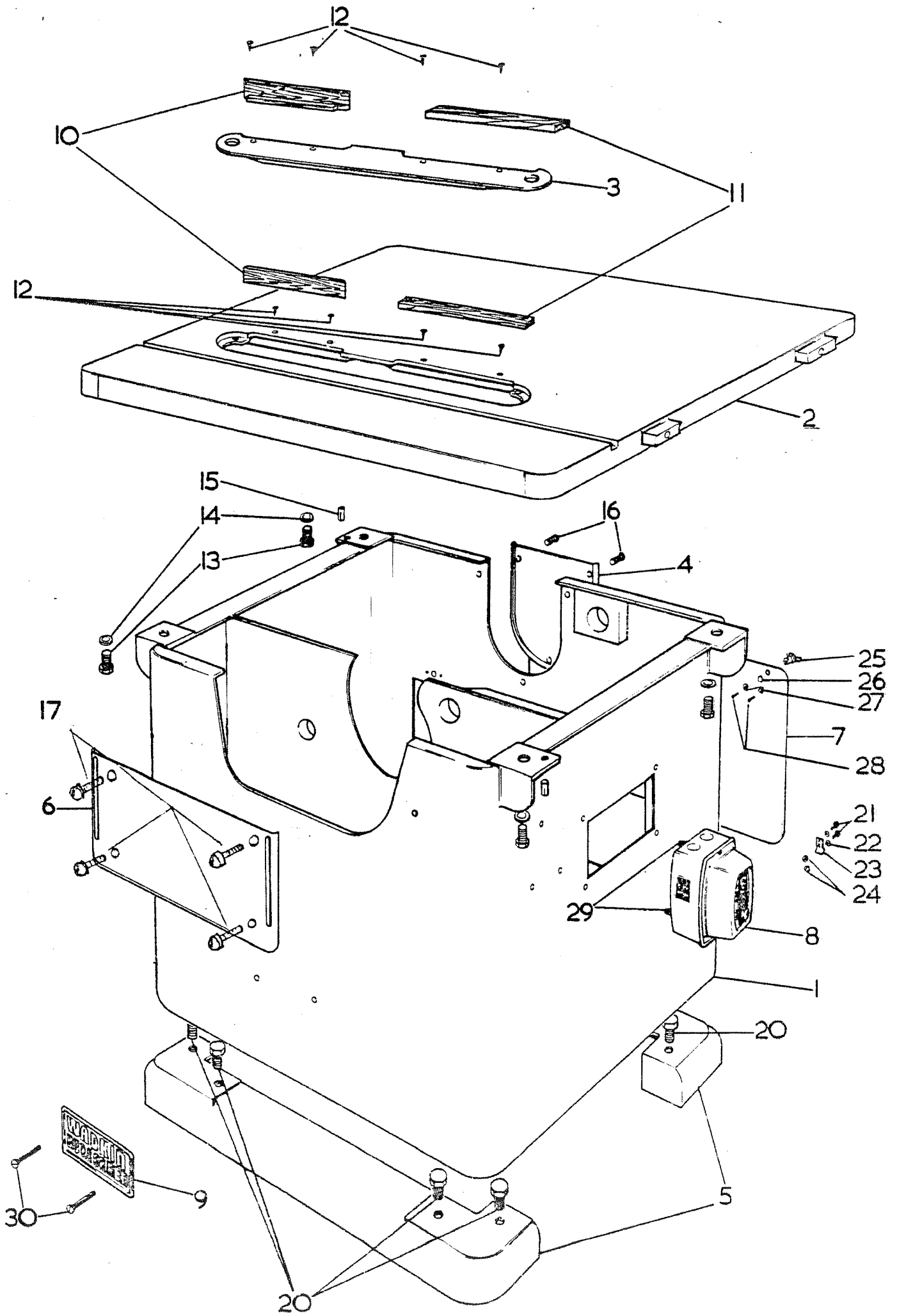

SAW SPINDLE ASSEMBLY

<u>REF NO.</u>	<u>PART NO.</u>	<u>NO. OFF</u>	<u>DESCRIPTION</u>
40	- - -	1	M32 FORM L.H. NUT
41	BSW 25	1	FRONT SAW FLANGE
42	BSW 80	1	SAW DRIVING PEG
43	BSW 24	1	REAR SAW FLANGE
44	BSW 5	1	HOUSING FRONT DUSTCAP
45	- - -	1	M6 x 88 mm LONG STUD
46	- - -	2	M6 LOCKNUTS
47	- - -	1	M6 x 92 mm STUD
48	- - -	2	SKF 6308 SINGLE ROW BEARINGS
49	BSS 57	1	REAR HOUSING DUSTCAP
50	- - -	2	M6 x 18 mm COUNTERSUNK SCREWS
51	BSW 519	1	MOTOR TENSION BRACKET
52	- - -	1	62 mm EXTERNAL CIRCLIP
53	BSW 761	1	PULLEY DISTANCE PIECE
54	BSW 21/A	1	SPINDLE PULLEY
55	- - -	1	M6 x 25 mm LONG ALLEN GRUB SCREW
56	- - -	1	M6 x 30 mm LONG ALLEN GRUB SCREW
57	- - -	1	M12 x 25 mm COUNTERSUNK 'SELF LOK'
58	BSW 61/A	1	SPINDLE PULLEY WASHERS
59	- - -	1	10 mm SQUARE x 40 mm LONG SINGLE ROUND END KEY
60	BSW 40	1	SPINDLE
61	- - -	2	KINGFISHER NO.2 GREASE CUPS

NOTE: PART NO. BSW 519 IS ALSO USED ON RISE AND FALL UNIT (SEE PAGE 29, PART NO. 92)

WHEN ORDERING SPARE PARTS PLEASE QUOTE PART NUMBER AND SERIAL NUMBER OF MACHINE.

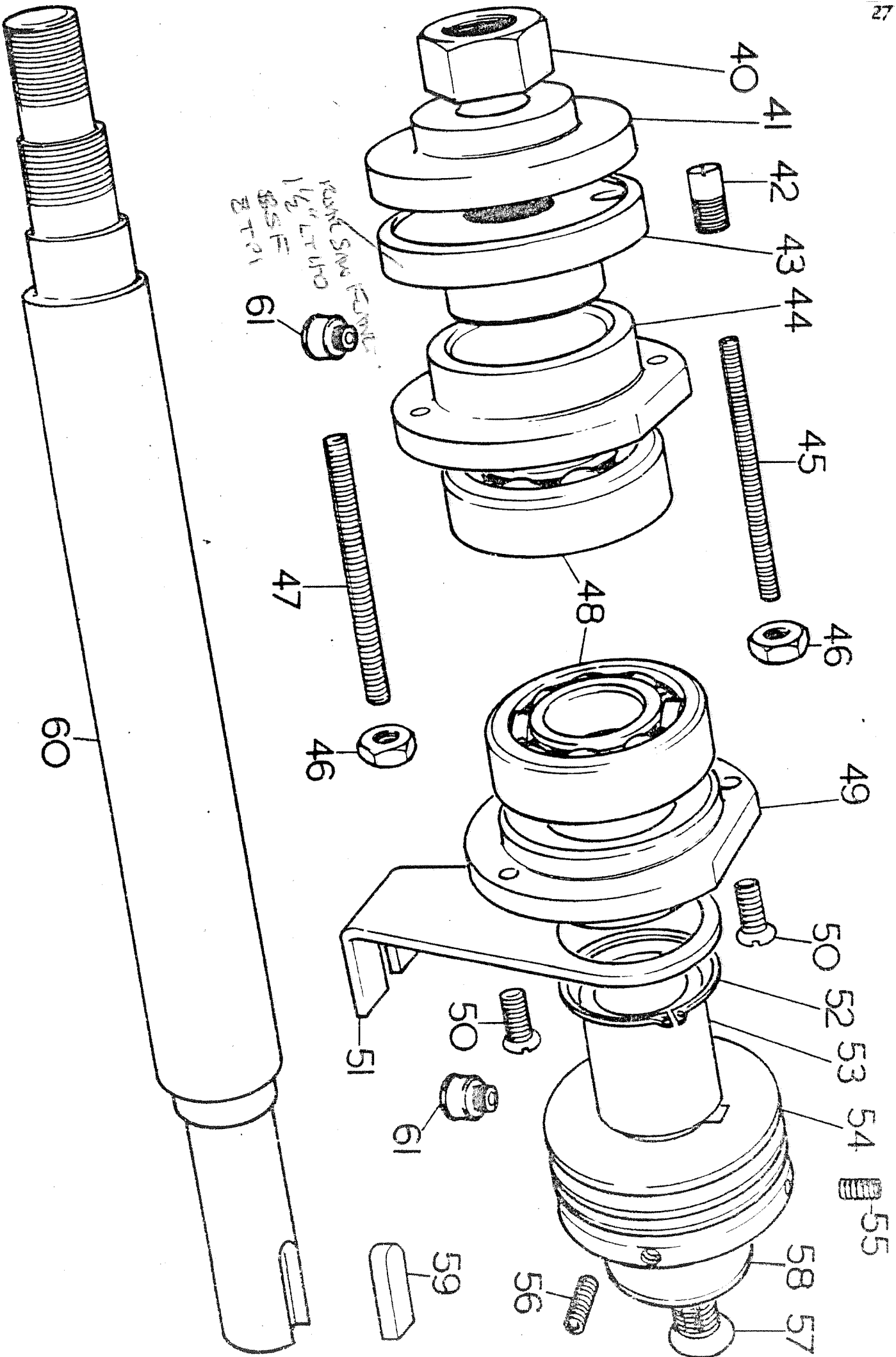

SAW RISE & FALL ASSEMBLY

70	BSW 9	1	225 mm DIA ALUMINIUM RISE AND FALL HANDLE	28
73	- - -	4	M10 x 35 LONG HEXAGON BOLTS	
74	- - -	9	10 mm WASHERS	
75	S 125/A	1	HANDWHEEL SPINDLE	
76	6698/A	1	10 mm BORE x 80 MM PLASTIC HANDLE	
77	BSW 10	1	RISE AND FALL BEARING BRACKET	
78	5296/3	1	40 mm x M10 BORE PLASTIC BALL	
79	BSW 35	1	RISE AND FALL LOCK HANDLE SHAFT	
80	BSW 19	1	LOCKING LINK	
81	- - -	4	12 mm EXTERNAL CIRCLIPS	
82	BSW 37	2	RISE AND FALL LOCK LINK PINS	
83	BSW 34	2	RISE AND FALL SCREW COLLARS	
84	- - -	3	M6 x 6 mm LONG GRUB SCREWS	
85	- - -	2	5 mm DIA x 30 mm LONG GROOVELOCK DOWELS	
86	SKF 0.6	1	THRUST RACE	
87	BSW 46	1	THRUST RACE SHROUD	
88	BSW 33	1	RISE AND FALL SCREW PIVOT	
89	- - -	1	20 mm I/D x 22 mm O/D x 22 mm LONG OILITE BUSH	
90	- - -		MOTOR SHAFT KEY (7.5 HP 10 mm x 8 mm)	
91	- - -	3	M6 x 20 mm LONG COUNTERSUNK SCREWS	
92	BSW 519	1	MOTOR TENSION BRACKET	
93	- - -	1	62 mm EXTERNAL CIRCLIP	
94	- - -	2	M8 x 30 mm LONG GRUB SCREWS	
95	BSW 32	1	SAW RISE AND FALL SCREW	
96	BSW 111/A	1	MOTOR PULLEY 7.5 HP	
97	- - -	1	16 mm DIA EXTERNAL CIRCLIP	
98	BSW 36	1	RISE AND FALL LOCK LINK	
99	BSW 43	1	MOTOR PIVOT SHAFT	
100	- - -	2	M10 x 35 MM STUDS	
101	BSW 7/A	2	MOTOR PIVOT BLOCKS	
102	BSW 7	2	MOTOR PIVOT BLOCKS	
103	BSW 134	2	MOTOR PIVOT SHAFT COLLARS	
104	- - -	4	M8 x 10 mm GRUB SCREWS	
105	- - -	3	M10 NUTS	
106	- - -	6	12 mm WASHERS	
107	- - -	2	M12 x 25 mm HEXAGON BOLTS	
108	- - -	2	M10 x 12 mm DOG POINT GRUB SCREWS	
109	BSW 42	2	SPINDLE HOUSING PIVOT SHAFT COLLARS	
110	BSW 31	1	RISE AND FALL SCREW NUT	
111	- - -	1	M20 LEFT HAND THREAD LOCK NUT	
112	BSW 124	1	RISE AND FALL SCREW LOCK COLLAR	
113	- - -	2	M12 LEFT HAND THREAD LOCKNUTS	
114	- - -	2	M12 LOCKNUTS	
115	BSW 142	1	MOTOR TENSION SCREW	
116	BSW 147	1	MOTOR TENSION SCREW	
117	BSW 135	1	TENSION NUT	
118	ALPHA 500	3	'SPACESAVER' VEE ROPES	
119	BSW 4	1	SAW SPINDLE HOUSING	
120	BSW 50	1	SUPPORT PLATE LINK	
121	BSW 51	1	SUPPORT PLATE LINK PIN	
122	BSW 49/A	1	SUPPORT PLATE LINK PIN (KNURLED)	
123	BSW 41	1	SPINDLE HOUSING PIVOT SHAFT	
124	BSW 29/A	1	RIVING KNIFE SUPPORT PLATE	
125	BSW 30	1	4 mm THICK STANDARD RIVING KNIFE	
126	- - -	4	M6 x 12 mm LONG GRUB SCREWS	
127	BSW 54	1	RIVING KNIFE HOLDER	
128	BSW 53	1	RIVING KNIFE HOLDER PACKING PIECE	
129	- - -	2	M10 x 45 mm COACH BOLTS	
130	- - -	3	M16 LOCKNUTS	
131	BSW 38	1	RISE AND FALL LOCK COLLAR	
132	BSW 18/A	1	SPINDLE HOUSING LINK	
133	- - -	1	16 MM WASHER	
134	- - -	1	16 mm SPECIAL SLOTTED WASHER	
135	BSW 20	1	LOCKING LINK NUT	
136	BSW 39	1	RISE AND FALL LOCK SCREW	
137	BSW 62	1	LINK PIVOT STUD	
138			7.5 HP (5.5 KW) D132S FRAME	

CANTING FENCE ASSEMBLY

<u>REF</u> <u>NO.</u>	<u>PART</u> <u>NO.</u>	<u>NO.</u> <u>OFF</u>	<u>DESCRIPTION</u>
160	BSW 15	1	FRONT FENCE PLATE
161	- - -	3	M6 x 6 mm CHEESE HEAD SCREWS
162	BSW 8	1	DOVETAIL BOLT
163	BSW 14	1	BACK FENCE PLATE
164	- - -	1	M6 x 10 mm GRUB SCREW
165	- - -	1	12 mm WASHER
166	- - -	1	M12 LEVER LOCK HANDLE
167	BSW 83	1	TURNOVER BRACKET SCREW
168	- - -	3	M10 LOCKNUTS
169	BSW 66	1	FENCE PIVOT SCREW (ECCENTRIC)
170	BSW 65	1	FENCE PIVOT SCREW (TRUE)
171	- - -	1	M8 x 12 mm GRUB SCREW
172	- - -	1	M8 LOCKNUT
173	BSW 16	1	FENCE CANTING LINK
174	- - -	1	10 mm EXTERNAL CIRCLIP
175	BSW 17	1	FENCE LINK PIVOT PIN
176	- - -	1	M16 LEVER LOCK HANDLE
177	- - -	1	M6 x 6 mm GRUB SCREW
178	BSW 57/A	1	BRASS LOCKING PAD
179	- - -	1	M12 x 50 mm STUD
180	- - -	1	16 mm EXTERNAL CIRCLIP
181	BSW 123	1	FINE ADJUSTMENT SCREW COLLAR
182	BSW 58	1	THUMB SCREW
183	BSW 526	1	FINE ADJUSTMENT BRACKET
184	BSW 63	1	FINE ADJUSTMENT SCREW
185	BSW 57	1	BRASS LOCKING PAD
186	- - -	1	12 mm WASHER
187	- - -	1	M12 LEVER LOCK HANDLE
188	BSW 12	1	TURNOVER BRACKET
189	BSW 56	1	RULE POINTER
190	BSW 139	1	METRIC RULE BAR
191	- - -	2	M10 x 30 mm ALLEN SCREWS

WHEN ORDERING SPARE PARTS PLEASE QUOTE PART NUMBER AND SERIAL NUMBER OF THE MACHINE

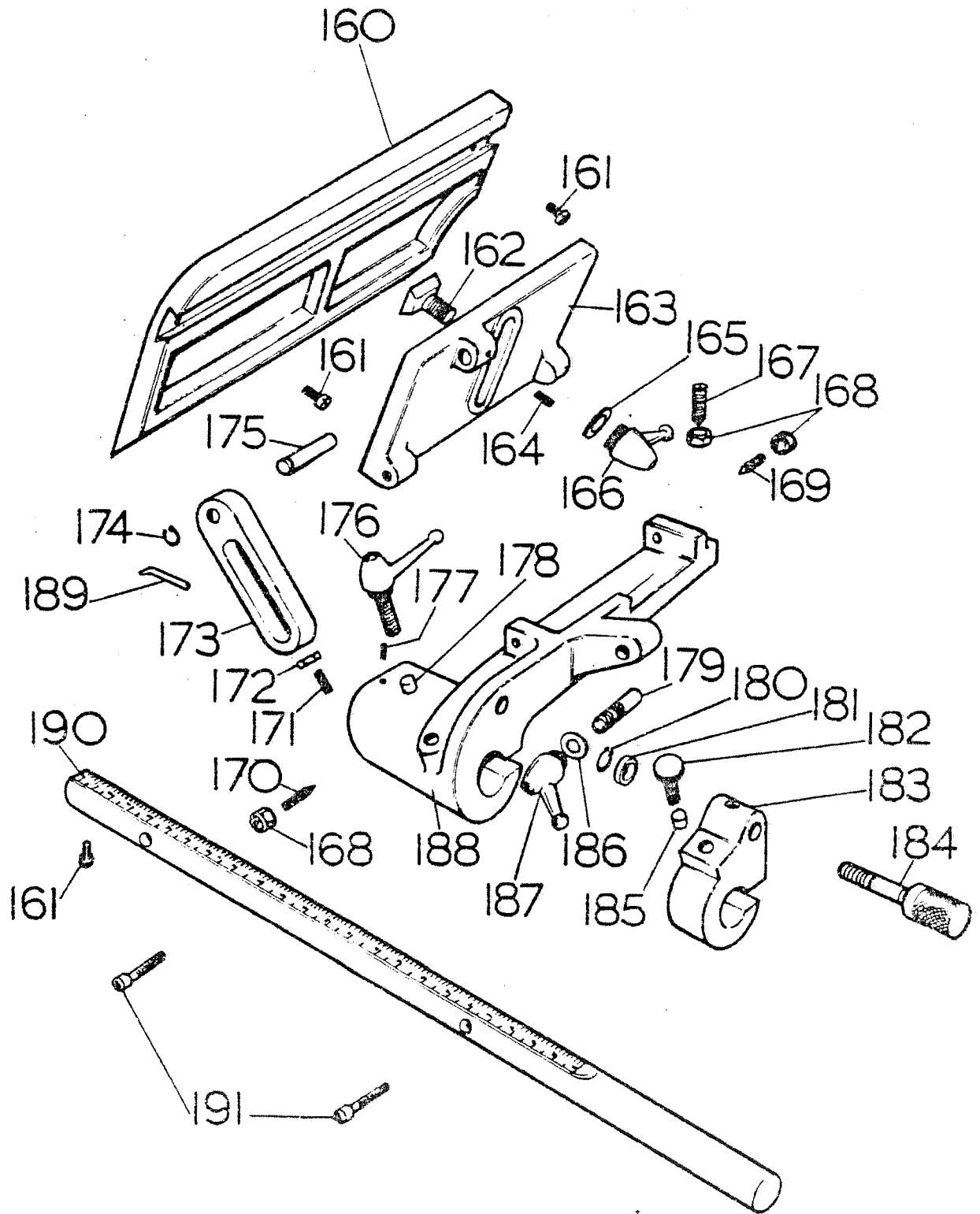

PILLAR GUARD ASSEMBLY

<u>REF.</u> <u>NO.</u>	<u>PART</u> <u>NO.</u>	<u>NO.</u> <u>OFF</u>	<u>DESCRIPTION</u>
200	---	3	M10 LOCKNUTS
201	---	1	10 mm SPRING WASHER
202	---	2	10 mm WASHER
203	BSW 79	1	SAW GUARD SHAFT
204	STOCK	1	M10 TEE LOCK HANDLE
205	BSW 57	1	BRASS LOCKING PAD
206	BSW 73	1	SAW GUARD REAR COVER
207	BSW 72	1	SAW GUARD
212	BSW 71	1	BRACKET FOR SAW GUARD
	BSW 121	1	BRACKET FOR SAW GUARD (LARGE TABLE)
213	---	1	5 mm x 37 mm GROOVELOCK DOWEL
214	---	1	6 mm x 50 mm GROOVELOCK DOWEL
215	---	1	M8 x 12 mm SQUARE HEAD BOLT
216	---	1	M8 LOCKNUT
217	---	1	M12 LEVER LOCK HANDLE
218	BSW 82	1	LOCKING KEY
219	BSW 69	1	SAW GUARD RISE AND FALL CAP
220	---	3	12 mm WASHERS
221	---	3	M12 x 37 mm HEXAGON BOLTS
222	---	1	5 mm x 25 mm GROOVELOCK DOWEL
223	BSW 70	1	GUARD RISE AND FALL HANDLE ARM
224	S125/A	1	GUARD RISE AND FALL HANDLE SPINDLE
225	6698/A	1	PLASTIC GUARD RISE AND FALL HANDLE
226	BSW 77	1	SAW GUARD RISE AND FALL SCREW COLLAR
227	---	1	M12 x 45 mm SQUARE HEAD LOCK BOLT
228	BSW 76	1	SAW GUARD RISE AND FALL SCREW
229	BSW 68	1	SAW GUARD RISE AND FALL BOSS
230	BSW 75	1	SAW GUARD COLUMN
231	---	1	M6 x 10 mm GRUB SCREW
232	BSW 67	1	SAW GUARD BASE CASTING
233	BSW 78/A	1	SAW GUARD SUPPORT ARM

MITRE FENCE ASSEMBLY

240	A-1026/220	1	MITRE FENCE PLUNGER BRACKET
241	A-1026/226	1	MITRE FENCE LOCATION PIN
242	ETS 30	1	PLUNGER SPRING
243	5103-25	1	PLUNGER CIRCLIP
244	---	2	M5 x 10 mm SCREWS
245	Z4	2	8 mm LONG SELF TAPPING SCREWS
246	A-1026/227	1	PLUNGER BRACKET COVER
247	---	1	M8 x 45 MM DIA PLASTIC HANDWHEEL
248	A-1026/174	1	8 mm WASHER FOR MITRE FENCE
240	---	1	M8 x 37 mm STUD
250	---	2	M6 THUMB SCREWS
251	D-1026/219	1	MITRE FENCE BODY
252	---	1	PIVOT PIN FOR MITRE FENCE
253	B1026/69	1	MITRE FENCE STOPROD (CRANKED)
254	B-1026/69	1	MITRE FENCE STOPROD (STRAIGHT)
255	---	1	MITRE FENCE TABLE STRIP
256	---	2	M6 WING NUTS
257	A-1026/68	4	MITRE FENCE STOP PLATES
258	A-1026/73	2	MITRE FENCE STOP PLATE SPRINGS
259	---	2	M6 x 20 mm COACH BOLTS

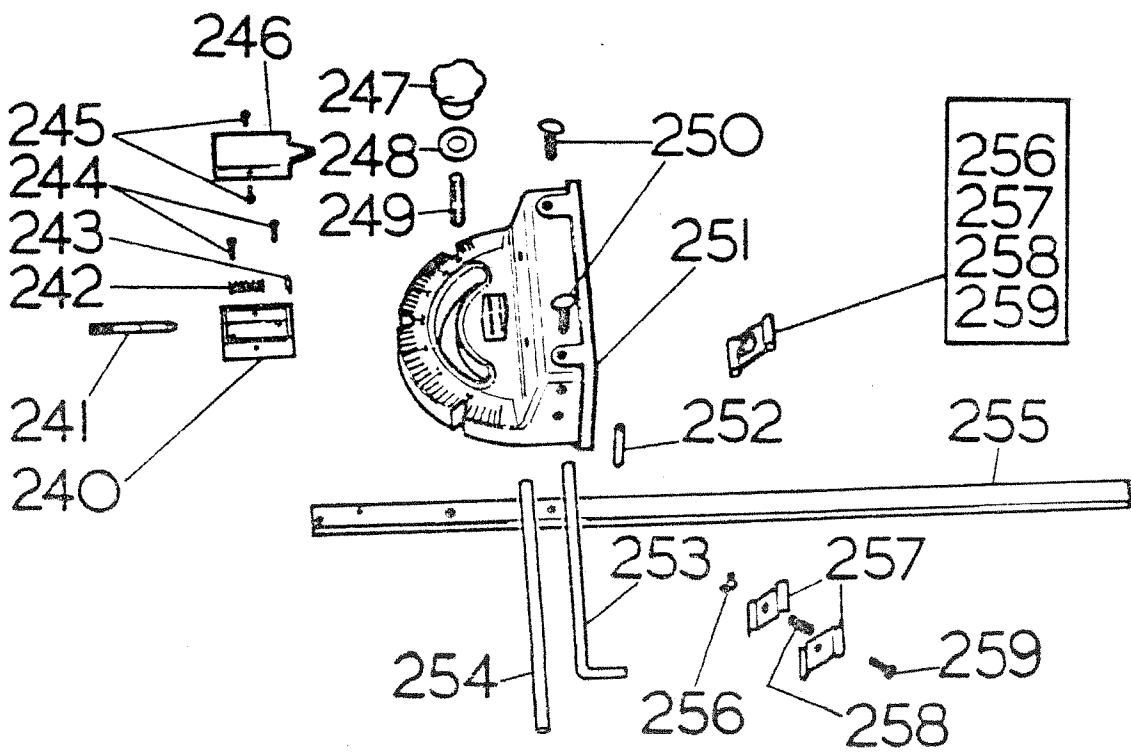
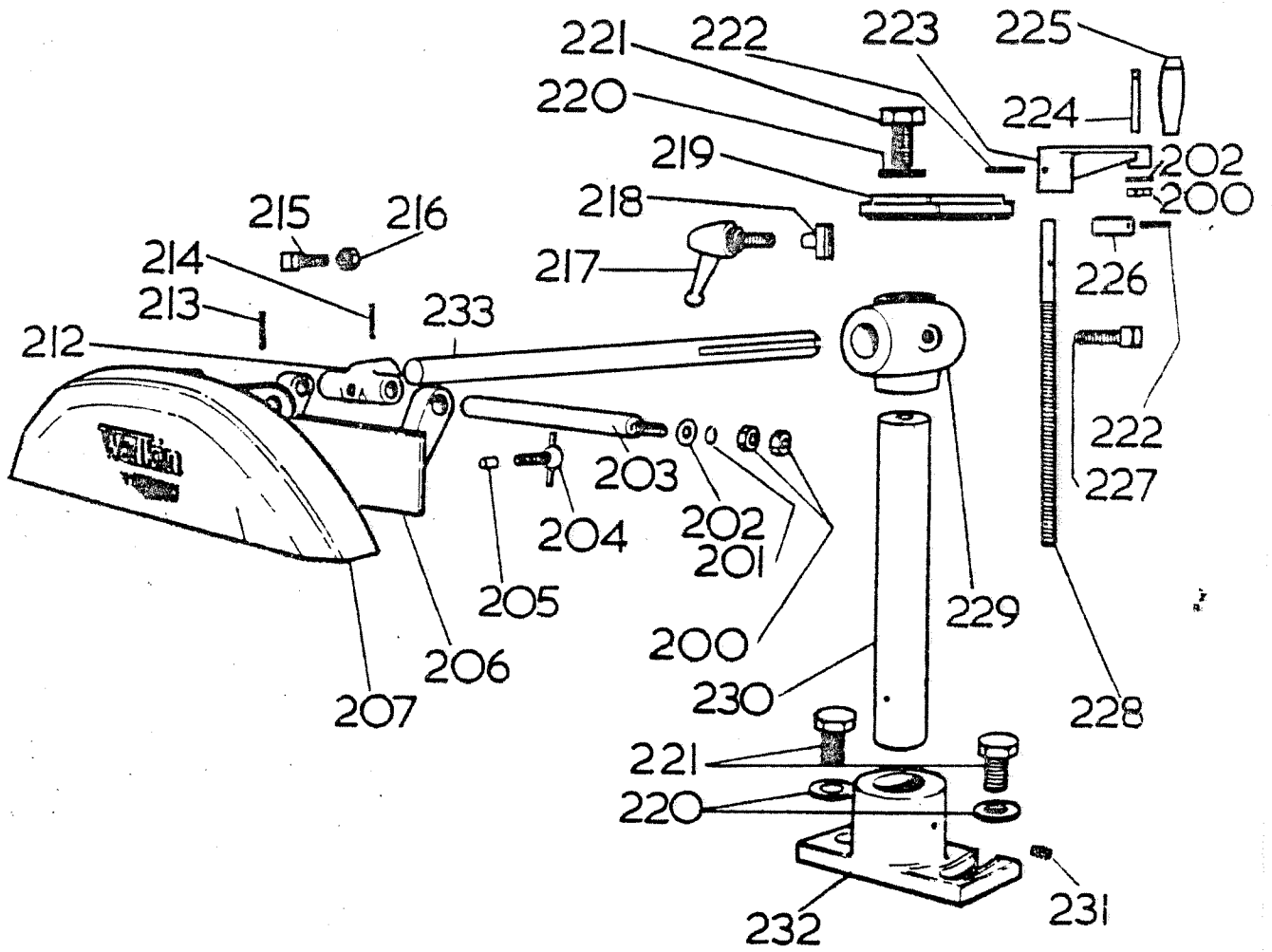

SPINDLE BRAKE ASSEMBLY

<u>REF</u> <u>NO.</u>	<u>PART</u> <u>NO.</u>	<u>NO.</u> <u>OFF</u>	<u>DESCRIPTION</u>
290	BSW SSA ---	1	20" BSW BRAKE CABLE
291	BSW 131	1	BRAKE POST
292	---	2	M5 LOCKNUTS
293	---	1	12 mm WASHER
294	---	1	M12 NUT
295	---	1	M6 x 10 mm GRUB SCREW
296	BSW 148	1	BRAKE STOP SCREW
297	---	1	46 mm BRAKE RETURN SPRING
298	BSW 145	1	PAD ALIGNMENT SPRING
299	---	2	M6 LOCKNUTS
300	---	2	M8 LOCKNUTS
301	---	1	M8 SPECIAL WASHER
302	---	1	22 mm O/D x 10 mm I/D x 12 mm LONG OILITE BUSH
303	BSW 132	1	BRAKE ARM
304	BSW 129	1	BRAKE PIVOT PIN
305	107.PA 7/8 RH	1	BRAKE LEVER COMPLETE
306	BSW 128	1	BRAKE LEVER ARM
307	---	1	M8 x 12 mm GRUB SCREW
308	BSW 125	1	SPECIAL SPINDLE PULLEY FOR BRAKE
309	---	1	M8 x 16 mm GRUB SCREW
310	---	1	M6 x 50 mm COUNTERSUNK SCREW
311	---	2	3 mm DIA COPPER RIVETS
312	---	1	BRAKE LINING FOR 20" BSW
313	BSW 133	1	BRAKE PAD BACKPLATE

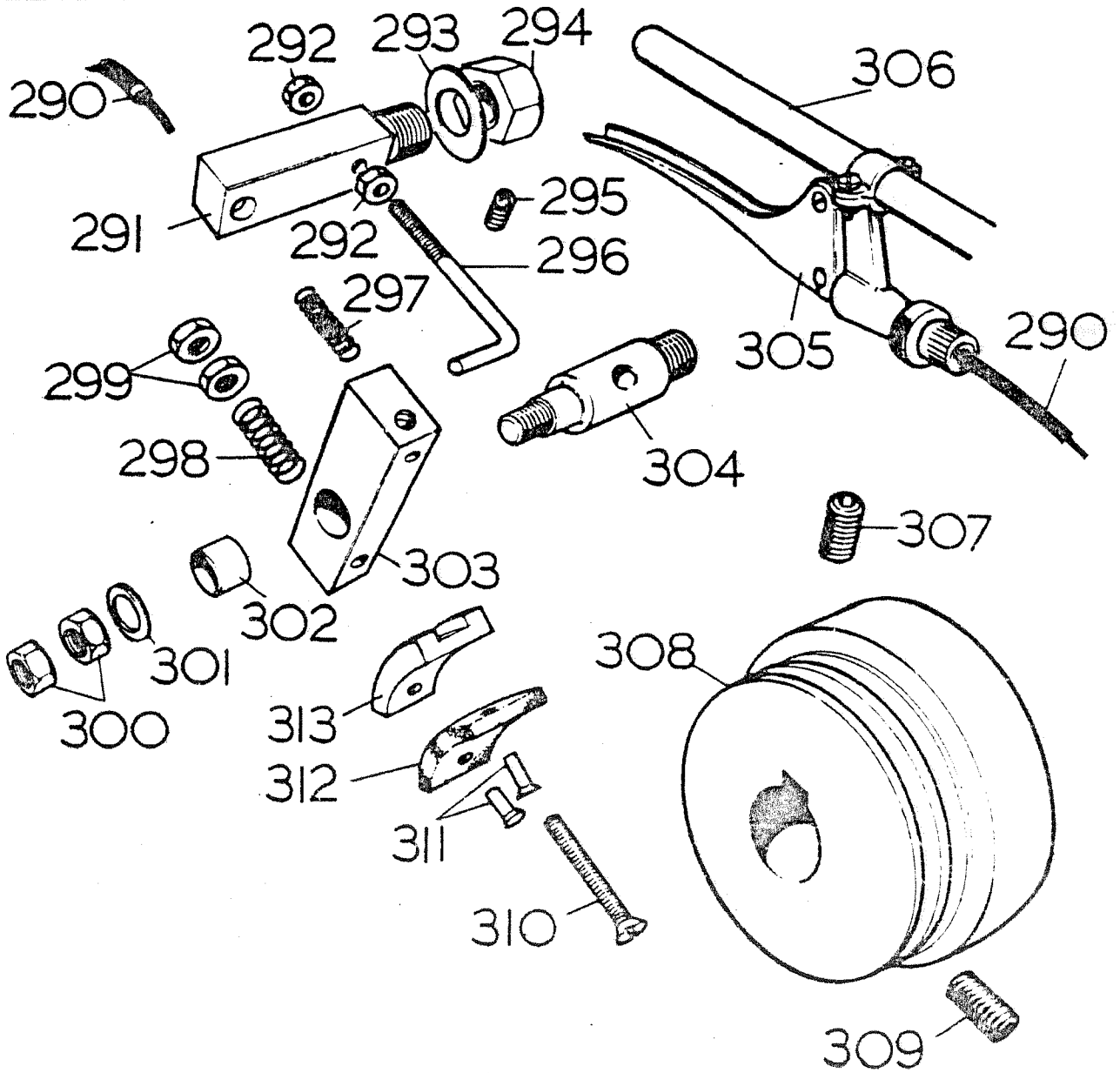

WHEN ORDERING SPARE PARTS PLEASE QUOTE PART NUMBER AND SERIAL NUMBER OF MACHINE



RECOMMENDED SPARE PARTS.

PART	QTY	REF
SPINDLE BEARINGS	2	S.K.F. 6308
RISE & FALL SCREW THRUST RACE	1	" 0.6
VEE-BELTS	3	ALPHA 500
FELT SAW PACKINGS	2	12 x 11 x 100 mm
<u>ELECTRICS 380/440-3Ph-50Cyc</u>		
FIXED & MOVING CONTACTS	1 Set	BROOK RT3 STARTER
NO VOLT COIL	1	" " "
OVERLOAD UNIT U16	1	" " "
FIXED & MOVING CONTACTS	3 Sets	BROOK RYD. STARTER
NO VOLT COIL	1	" " "
OVERLOAD UNIT	1	" " "
TIMER	1	" " "

STANDARD STOCK SAWS.

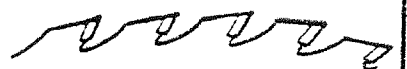
BC21	20(500mm) DIAMETER ALLOY CROSSCUT SAW.	
BC20	20(500mm) DIAMETER GENERAL PURPOSE ALLOY RIP SAW.	
BC22	20(500mm) DIAMETER CHROME PLATED RIP SAW.	
BC 123	20(500mm) DIAMETER TUNGSTEN CARBIDE TIPPED RIP SAW.	

OTHER TYPES OF SAWS FOR CUTTING PLASTICS & PLYWOOD ARE AVAILABLE, DETAILS OF WHICH CAN BE APPLIED FOR OR BE SEEN IN THE Wadkin SMALL TOOLS CATALOGUE.