



T: 0116 2769111

F: 0116 2598138

**'Wadkin' Through Feed
Four Side Planing Machine
and Moulder**

**Model SUPER 220 XJS
& XJ/K**

INSTRUCTION MANUAL No. 2020/5

MANUFACTURERS E.C. DECLARATION OF CONFORMITY

The following machine has undergone "Conformity Assessment" and is "self" certified in accordance with:-

Supply of Machinery (Safety) Regulations 1992
and Amendment No. 2063

COMPANY

WADKIN LTD
Green Lane Road
Leicester
LE5 4PF

RESPONSIBLE PERSON

Mr A C Lott (Managing Director)

MACHINE DESCRIPTION

TYPE THROUGH FEED FOUR SIDE
PLANING MACHINE AND MOULDER

MODEL SUPER 220 XJS & XJ/K

DIRECTIVES COMPLIED WITH

Supply of Machinery (Safety) Regulations 1992
Amendment No. 2063 1994
Draught Proposal CEN/TC 142
ISO 9001 Part 1

SIGNED ON BEHALF OF WADKIN PLC



.....



IMPORTANT

SAFETY PROCEDURES AND CONSIDERATIONS

To ensure safe working conditions, persons operating and assisting with the operation of this machine must ensure that they read and fully understand the instructions given within this manual and have received sufficient training in the use of the machine and the safety aspects to be observed.

Note:- Persons under the age of 18 years must not operate the machine except during the course of training under the supervision of a trained operator.

- A) POINTS TO NOTE BEFORE OPERATING OR ASSISTING WITH THE OPERATION OF THE MACHINE.**
- 1) You have read and understand the operation and safety aspects of the machine and have been checked out by a qualified supervisor.
 - 2) The machine is supplied with full safe guarding. The machine shall not be operated unless the safe guardings are in position and are functional.
 - 3) Cutters/blades are the correct type, suitable for the machine and working conditions, rotate in the correct direction of cut, are sharp and correctly fitted.
 - 4) Correct spindle and speeds are selected for the cutter equipment and working conditions.
 - 5) Loose clothing is either removed or securely fastened back and jewellery removed.
 - 6) Adequate working space and lighting is provided.
 - 7) All dust extraction equipment is switched on, properly adjusted and working adequately.
 - 8) The machine is securely installed (refer to installation section within this manual).
 - 9) The machine should only be used for cutting wood or materials with physical and technological characteristics similar to wood, and for which the chip or particle removal process is similar.
 - 10) Only use tooling that complies with prEN 847-1. Sawblades made of High Speed Steel (HSS) MUST NOT be used.
-



B) DURING MACHINING:-

- 1) Wear suitable protective clothing e.g, approved eye protection, ear defenders and dust masks. Gloves shall be worn when handling tooling.
- 2) Stop the machine using the emergency stop or at the mains isolator before making adjustments, cleaning or carrying out maintenance.
- 3) Keep the floor area around the machine clean and free from wood refuse. Do not allow the floor around the machine to become slippery.
- 4) Stop the machine and report immediately to a person in authority any actual or potential malfunction or operator hazard. Do not attempt to repair or rectify the machine unless qualified or authorised to do so.
- 5) The operator must not leave the machine running whilst unattended.
- 6) Never by-pass interlocks.

WARNING:-

Failure to observe correct operating procedures prior to and during operation of this machine can result in severe injury.

DO NOT attempt to operate the machine while under the influence of anything that reduces your alertness.



PREFACE

IMPORTANT

IT IS OUR POLICY AND THAT OF OUR SUPPLIERS TO CONSTANTLY REVIEW THE DESIGN AND CAPACITY OF OUR PRODUCTS. WITH THIS IN MIND WE WOULD REMIND OUR CUSTOMERS THAT WHILE THE DIMENSIONS AND PERFORMANCE DATA CONTAINED HEREIN ARE CURRENT AT THE TIME OF GOING TO PRESS, IT IS POSSIBLE THAT DUE TO THE INCORPORATION OF THE LATEST DEVELOPMENTS TO ENHANCE PERFORMANCE, DIMENSIONS AND SUPPLIERS MAY VARY FROM THOSE ILLUSTRATED

THIS MANUAL IS WRITTEN AS A GENERAL GUIDE. DUE TO THE NUMBER OF VARIATIONS (OPTIONS) AVAILABLE A TYPICAL MACHINE IS SHOWN TO ILLUSTRATE THE MAIN FEATURES.

Wadkin Leicester

Green Lane Works, Leicester LE5 4PF, England.
Telephone: 0116 2769111
Fax: 0116 2598138



SAFEGUARDING MACHINES

To comply with the Woodworking Machines Regulations 1974, operators must ensure that they fully understand the instructions given and have received sufficient training in the use of the machine and the particular safety instructions to be observed.

NOTE: Persons under the age of 18 years must not operate the machine except under supervision during a course of training.

BEFORE OPERATING THE MACHINE ENSURE THAT:-

All guards and fences are securely fitted and correctly adjusted in accordance with the Regulations.

Cutters / Blades are the correct type and rotate in correct direction of cut, are sharp and securely fastened.

Correct spindle speed is selected for the cutter equipment.

Loose clothing is either removed or fastened and jewellery removed.

Suitable jigs and push sticks are available as appropriate.

Sufficient working space is provided and lighting is adequate.

All dust extraction equipment is switched on, properly adjusted and working efficiently.

DURING MACHINING:-

Wear suitable protective equipment, e.g. goggles, ear defenders, and dust mask.

Stop the machine before making adjustments or cleaning chips from the work area.

Keep the floor area around the machine clean and free from wood refuse.

Do not allow the floor to become slippery with oil or grease

Report immediately to a person in authority, any machine malfunction or operator hazard. Do not attempt to repair the machine unless qualified to do so.

Ensure all power sources are isolated before commencing any maintenance work

WARNING: Failure to comply with the Regulations is a criminal offence and could result in legal proceedings.



HEALTH AND SAFETY

This machine is designed and constructed using the principles of safeguarding and practical guidance contained in the British Standard Codes of Practice BS5304: 1988 "Safeguard of machinery", BS6854: 1987 "Safeguard woodworking machines" and current guidance issued by the Health and Safety Executive.

The Health and Safety at Work etc Act 1974 places duties in designers, manufacturers and suppliers to ensure that:-

1. Articles supplied for use at work are, so far as is reasonably practicable, safe and without risks to health during setting, use, cleaning and maintenance.
2. Persons supplied with the articles are provided with adequate information about the use for which they are designed, and about conditions necessary to ensure that they will be safe and without risks to health.

These duties are transferred to you if you resupply the machine by way of sale, lease, hire or hire-purchase.

Persons who install this machine for use at work have a duty under the Health and Safety at Work etc Act 1974, to ensure so far as is reasonably practicable, that nothing about the way in which it is installed makes it unsafe or a risk to health. This includes such aspects as correct assembly, electrical installation, construction of enclosures, fitting of guards and exhaust ventilation equipment. When installing the machine, consideration must be given to the provision of adequate lighting and working space.

The legal duties of designers, manufacturers, importers, suppliers, erectors and installers are explained in the free Health and Safety Executive leaflet IND (G) 1 (L) 1987.

The machine is supplied complete with all necessary safeguards to enable the user to comply with the Woodworking Machines regulations 1974. Details of correct installation and use, together with guidance on fitting and proper adjustment of guards are described in Sections 1 to 4 of this manual.

You are reminded that the Woodworking Machines Regulations place absolute legal duties on employers and employees to ensure that guards and any other safety devices are securely fitted, correctly adjusted and properly maintained.

Repairs and maintenance must only be undertaken by suitably qualified and competent technicians. Ensure that all power supplies are isolated before any maintenance work commences. Instructions of routine maintenance are given in Section 4 of this manual.

Machine operators must have received sufficient training and instruction as to the dangers arising in connection with the machine, the precautions to be observed and the requirements of the Woodworking Machines Regulations which apply, except where they work under the adequate supervision of a person who has a thorough knowledge and experience of the machine and the required safeguards.

Persons under the age of 18 years must successfully complete an approved course of training before operating this machine at work, unless participating in a course of training under adequate supervision. (N.B. This paragraph is only relevant to; circular sawing machines, any sawing machines fitted with a circular blade, any planing machine for surfacing which is not mechanically fed or any vertical spindle moulding machine.)

Before commencing work, ensure that the cutters/blades are, set to cut in the correct direction, securely fitted, sharp, and are compatible with the machine and spindle speed.

Dust

Wood dust can be harmful to health by inhalation and skin contact and concentrations of small dust particles in the air can form an explosive mixture. These concentrations usually occur in dust extraction equipment which may be destroyed unless explosion precautions have been taken in the design and installation of the equipment.

Employees have duties under the Factories Act 1961 and Health and Safety at Work etc Act 1974 to control wood dust in the workplace and from 1st October 1989 more specific requirements will be imposed by the Control of Substances Hazardous to Health Regulations 1988.

Employers should carry out an adequate assessment of the possible risks to health associated with wood dust to enable a valid decision to be made about the measures to control the dust. It may be necessary to provide effective exhaust appliances.

Prevention or control of wood dust exposure should so far as is reasonably practicable, be achieved by measures OTHER than the provisions of personal protective equipment.

Airborne dust levels should not exceed 5 mg/cub.m

Further information and reference to practical guidance are contained in the following free leaflets from the Health and Safety Executive:-

Wood dust: IND(S) 10 (L) 1987
Hazards and precautions
Control Hardwood Dust IND(S) 21 (L) 1988

Noise

Noise levels can vary widely from machine to machine depending on conditions of use. Persons exposed to high noise levels, even for a short time, may experience temporary partial hearing loss and continuous exposure to high levels can result in permanent hearing damage. The Woodworking machines Regulations require employers to take reasonably practicable measures to reduce noise levels where any person is likely to be exposed to a continuous equivalent noise level of 90 dB(A) or more, over an 8 hour working day. Additionally, suitable ear protectors must be provided, maintained and worn.

An adequate assessment of likely noise exposure should be made using manufacturers data and if necessary, a noise survey should be carried out by a competent person. It may be necessary to construct a suitable noise enclosure, in which case professional advice should be sought.

Machines identified as generating unhealthy noise levels should be appropriately marked with a warning of the need to wear hearing protection and it may be necessary to designate particular areas of the workplace as "Ear protection zones". Suitable warning signs are specified in the Safety Signs Regulations 1980.

Further information and reference are contained in the free Health and Safety Executive leaflet - Noise at Woodworking Machines IND(S) 22(L) 1988.



Note: Because of the modular construction of the XJS only the sections relevant to each machine are included. It is also not possible to cover all the options and customers special requests that may have been added to their machine. If you should require information not contained within the manual please contact Wadkin at the address given on the front page.

CONTENTS

SECTION 1	OPERATING PRACTICES	PAGE NO.
	General notes	1-1
	Machine feed systems	1-2
	Noise	1-5
	Leading particulars	1-7
SECTION 2	LIFTING AND TRANSPORTATION	
	Unloading	2-1
	Moving	2-1
	Unpacking	2-1
	Cleaning	2-2
SECTION 3	INSTALLATION	
	Major dimensions and weight	3-1
	Locations and foundations	3-1
	Supplies and services	3-1
SECTION 4	GENERAL OPERATING INSTRUCTIONS	
	Safety	4-1
	Safety drives	4-1
	Warnings - before machining	4-1
	- during machining	4-2
	Machine controls	4-3
	Dial a size electronic positioning	4-4
	99 Setting programmable memory positioning	4-7
SECTION 5	HEAVY DUTY PUSH FEED MODULE	
	General	5-1
	Adjusting infeed table height	5-1
	Adjusting side pressure	5-1
	Bottom infeed roller adjustments	5-1
	Top infeed roller adjustment	5-2

CONTENT (cont)

SECTION 5 (cont)	Maintenance	PAGE NO.
	Routine maintenance	5-3
	Changing feed rolls	5-3
	Replacing top feed roller shaft bearings	5-4
	Replacing bottom feed roller shaft bearings	5-5
	Illustrated parts list	
	Bottom infeed rollers	5-11
	Top infeed rollers	5-13
	Pneumatic 'skid' type side pressure	5-15
	Side roller pressure	5-17
	Spring operated 'skid' type side pressure	5-19
SECTION 6	BOTTOM HEAD MODULE	
	General	
	Bottom head vertical and horizontal adjustment	6-1
	Adjustment to top and bottom through feed rollers	6-1
	Adjustment to top and bottom through feed rollers	6-2
	Adjustment to side pressure after bottom head	6-2
	Mounting the cutterblocks	
	General	6-5
	To change a cutterblock	6-6
	Maintenance	
	Routine maintenance	6-9
	Vee belt drive tensioning	6-9
	Replacing drive belts	6-10
	Remove and refit of drive pulleys	6-10
	Changing outboard bearing	6-11
	Illustrated parts list	
	Bottom head rise and fall	6-19
	Bottom head lateral adjustment	6-21
	Pneumatic 'skid' type side pressure	6-23
	Spring operated 'skid' type side pressure	6-25
	Outboard bearing - bottom head	6-27
SECTION 7	STAGGERED SIDE HEAD MODULE (300mm CENTRES)	
	General	
	General	7-1
	Fence side head	7-1
	Near side head	7-2
	Near side head chipbreaker and side pressure	7-3
	Side pressure opposite fence side head	7-3
	Top roller pressure - fence side head	7-4
	Adjustment to top and bottom through feed rolls	7-4

CONTENT(cont)

SECTION 7	Mounting the cutterblocks	
(cont)	General	7-5
	To change cutterblocks on fence and near side heads	7-6
	Safety collars	7-6
	Maintenance	
	Routine maintenance	7-9
	Vee belt drive tensioning	7-10
	Replacing vee belts	7-10
	Illustrated parts list	
	Fence side head carriage adjustments	7-13
	Spindle barrel locks for fence and near side heads	7-17
	Near side head carriage adjustment	7-19
	Motor rise and fall for side heads	7-23
	Spring operated 'skid' type side pressure	7-25
	Pneumatic operated 'skid' type side pressure	7-27
SECTION 8	CLOSE COUPLED STAGGERED SIDE HEAD MODULE (80mm CENTRES)	
	General	8-1
	Fence side head	8-1
	Near side head	8-2
	Near side head chipbreaker	8-2
	Side pressure opposite fence side head	8-3
	Top roller pressure - fence side head	8-4
	Adjustment to top and bottom through-feed rolls	8-4
	Mounting the cutterblocks	
	General	8-5
	To change cutterblocks on fence and near side heads	8-5
	Safety collars	8-6
	Maintenance	
	Routine maintenance	8-9
	Vee belt drive tensioning	8-10
	Replacing vee belts	8-10
	Illustrated parts list	
	Fence side head carriage adjustments	8-13
	Spindle barrel locks for fence and near side heads	8-17
	Near side head carriage adjustment	8-19
	Motor rise and fall for side heads	8-23
	Spring operated 'skid' type side pressure	8-25
	Pneumatic operated 'skid' type side pressure	8-27

CONTENT (cont)

SECTION 9	TOP HEAD MODULE	PAGE NO.
	General	9-1
	Top head vertical and horizontal adjustment	9-1
	Top head chipbreaker and pad pressure	9-3
	Adjustment to top and bottom through feed rollers	9-3
	Mounting the cutterblocks	
	General	9-5
	To change the cutterblock	9-5
	Maintenance	
	Routine maintenance	9-9
	Vee belt drive tensioning	9-10
	Replacing drive belts	9-10
	Removal and refit of drive pulleys	9-11
	Preparation prior to fitting bearings	9-12
	Outboard bearing change top head	9-12
	Outboard bearing housing removal	9-13
	Illustrated parts list	
	Top head axial adjustment	9-17
	Top head power rise and fall	9-19
	Pad pressure after top head	9-23
	Top head chipbreaker	9-25
	Outboard bearing	9-29
SECTION 10	TOP HEAD/BOTTOM HEAD MODULE	
	General	10-1
	Top head vertical and horizontal adjustment	10-1
	Top head chipbreaker and pad pressure	10-3
	Bottom head vertical and horizontal adjustment	10-3
	Adjustment to top and bottom through feed rollers	10-5
	Adjustment to side guide	10-5
	Mounting the cutterblocks	
	General	10-7
	Cutterblock change to top and bottom heads	10-7
	Maintenance	
	Routine maintenance	10-11
	Vee belt tensioning	10-11
	Replacing drive belts	10-12
	Removal and refit of drive pulleys	10-13
	Preparation prior to fitting bearings	10-13
	Outboard bearing change to top and bottom heads	10-14
	Outboard bearing housing removal - top and bottom heads	10-16



CONTENT (cont)

SECTION 10	Illustrated parts list	PAGE NO.
(cont)	Top head axial adjustment	10-19
	Top head power rise and fall	10-21
	Pad pressure after top head	10-25
	Top head chipbreaker	10-27
	Outboard bearing - top head	10-29
	Bottom head axial adjustment	10-31
	Bottom head rise and fall adjustment	10-33
	Outboard bearing - bottom head	10-35
SECTION 11	UNIT 'G' SPLITTING HEAD MODULE	
	General	
	Replacing/setting saws	11-1
	Vertical saw adjustment	11-1
	Lateral saw adjustment	11-1
	Anti-kick back fingers	11-2
	Adjustment to top pad pressure and riving knives	11-2
	Machining permali, bedplate and top pad pressure	11-3
	Side guide setting	11-3
	Maintenance	
	Routine maintenance	11-5
	Changing cutterblocks	11-5
	Replacing and tensioning drive belts	11-7
	Illustrated parts list	
	Spindle unit ('V' belt)	11-11
	Spindle unit (timing belt)	11-13
	Spindle rise and fall	11-15
	Axial spindle adjustment	11-17
	Chain tensioner to axial spindle adjustment	11-19
	Top pad pressure and riving knives	11-21
	Anti-kick back fingers	11-23
	Outboard bearing	11-25
SECTION 12	DRIVEN BED ROLLS AND TOP THROUGH FEED ROLLS	
	General	
	Setting driven bedrolls	12-1
	Adjusting top through feed rolls	12-2
	Maintenance	
	General	
	Changing top through feed rolls	12-3
	Changing bedrolls	12-3
	Preparation prior to fitting bearings	12-4
	Bearing change to top through feed rolls	12-4
	Bearing change to bed rolls	12-6

CONTENT (cont)

SECTION 12	Illustrated parts list	PAGE NO.
(cont)	Intermediate bed roll	12-11
	Shaft mounted feed roll	12-13
	Flange mounted feed roll	12-15
SECTION 13 GEARBOXES AND DRIVE SHAFTS		
	General	13-1
	Replacing feed roll drive shaft and coupling insert	13-1
	Replacing drive belt to bottom feed rolls	13-1
	Replacement of main feed drive belt (hydraulic drive)	13-3
	Tachometer belt replacement	13-3
	Replacing chain drive to beam rise and fall	13-3
	Illustrated parts list	
	Gearbox couplings	13-7
	Hydraulic drive transfer to feed roll gearboxes	13-11
	Belt Drive to bottom feed rolls	13-13
	Drive shafts to beam rise and fall	13-15
	Beam power rise and fall	13-17
	Gear drive to bottom feed rolls	13-19
	Direct hydraulic drive to feed roll gearboxes	13-21
SECTION 14 SPINDLES		
	General	14-1
	Spindle removal	14-1
	Preparation prior to fitting bearings	14-2
	Changing cutterblock spindle bearings	14-2
	Illustrated parts list	
	Spindle	14-7
SECTION 15 BEDPLATES AND FENCES		
	General	15-1
	Infeed fence removal and replacement	15-1
	Intermediate and outfeed fences	15-1
	Bedplate removal/replacement	15-2
	Bed lubrication	15-2
SECTION 16 JOINTERS		
	Principle and practice	16-1
	Straight jointing	16-3
	Profile jointing	16-3
	Jointer - fence side head	16-4
	Jointer - near side head	16-4
	Jointer - top head	16-5
	Jointer - second bottom head	16-6



CONTENT (cont)

SECTION 16	Maintenance	PAGE NO.
(cont)	General	16-7
	Illustrated parts list	
	Fence side head jointer	16-11
	Near side head jointer	16-15
	Second bottom head jointer	16-17
	Top head jointer	16-19
SECTION 17	HYDRAULIC DRIVE	
	General	17-1
	Maintenance	
	General	17-3
	Hydraulic feed drive belt	17-3
	Changing the pressure fluid	17-3
	Changing the filter	17-3
	Pressure fluids	17-3
	Fault finding procedure for pump and motor	17-5
	Illustrated parts list	
	Hydraulic drive unit	17-15
	Hydraulic drive transfer to feed roll gearboxes	17-17
	Direct hydraulic drive to feed roll gearboxes	17-19
SECTION 18	GENERAL OPERATING AND WORK FAULTS	
	Common operating problems	18-1
	Mechanical faults	18-3
	Elimination of vibration	18-3
	Electrical faults	18-3
	General workpiece faults	18-9
	Faults caused by tools	18-9
	Faults in grinding and setting	18-9
SECTION 19	TABLES	
	Approved lubricants	19-1
	Drive belt data	19-2
SECTION 20	OPTIONAL EXTRAS	
	Throating head	
	Setting and adjustment	20-1
	Illustrated parts list	20-2
	Universal Head	20-9

SECTION 1 GENERAL DESCRIPTION

OPERATING PRACTICE

General notes on all models of Wadkin Planing and Moulding Machines

A planing and moulding machine produces planed or moulded surfaces on all four sides of lengths of timber, both hard and softwood, at feed speeds determined by the cutter equipment and quality of surface finish required.

A series of 'ridges' (cutter marks) is created on the surface of the timber as it is moved past a rotating cutterblock (see Fig 1). The quality of surface finish is determined by the number of knife marks per 25mm (1") (the pitch of the cutter marks). The closer the pitch the better the quality of surface finish.

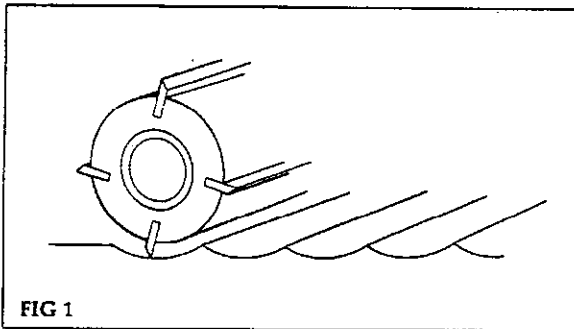

FIG 1

From experience a good quality surface finish has knife marks at a pitch of 1.5 to 2mm. Reducing the pitch improves the surface finish but increases the wear on the cutters, increasing the pitch reduces the quality.

The number of cutter knives in a cutterblock will only be effective when all are rotating in precisely the same cutting circle. Two main factors influence this.

- a. The fit of the cutterblock on the spindle
- b. The concentricity of grinding

The conventional method of mounting a cutterblock is to lock a plain bore block on to a plain ground spindle with a locknut. The tolerances in each component give a possible 0.05mm (0.002") clearance in the bore and thus eccentric running (see Fig 2).

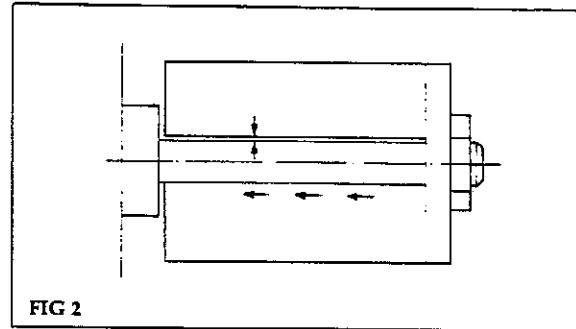

FIG 2

The Wadkin hydrofix locking system eliminates this clearance by pressurising the bore of the cutterblock onto the spindle (see Fig 3).

Axial locking is not required and a simple safety collar is recommended to prevent the cutterblock moving axially, or rotating on the spindle, if the hydraulic pressure is not applied.

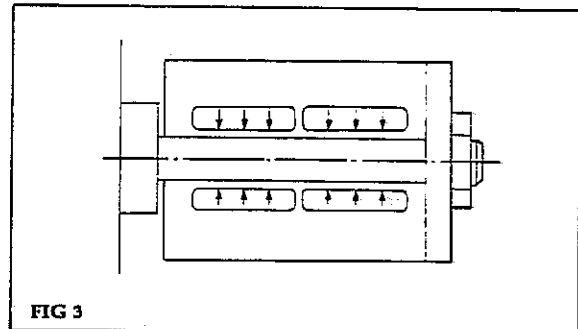
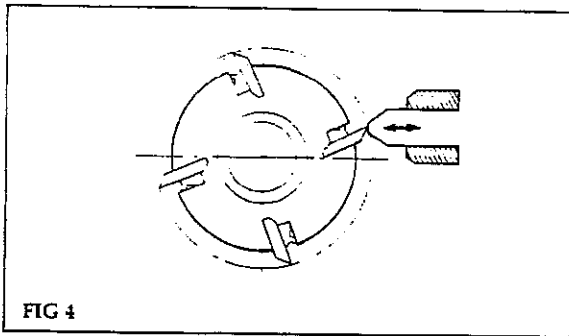

FIG 3

Because the Hydrofix locking is also used while the knives in the cutterblock are ground in the toolroom, it can be seen that the high accuracy of the grinding process is transferred directly to the planing and moulding machine. This accuracy, together with the true running of the precision spindle of the moulder, reduces the running of the knives to within 0.002 to 0.005mm of the true cutting circle. However, this minimum run-out is still such that only one knife leaves a finishing cut, no matter how many are in the block.

To ensure that all the knives in a cutterblock run in an absolutely true cutting circle, the technique of jointing is used, in which the jointing 'stone' trues all the knives while rotating at cutting speed in the planing and moulding machine (see Fig 4).



It can be seen that for a given spindle speed and quality of surface finish (pitch of knife marks), the feed speed may be increased in direct relationship to the number of knives in the cutterblock.

$$\text{Cuttermark pitch} = \frac{\text{Feed speed in mm per min}}{\text{Block rpm} \times \text{No of cutters}}$$

For example $\frac{12 \times 1000}{6000 \times 1} = 2\text{m pitch}$

for a spindle running at 6000 rpm and a feed speed of 12m/min and unjointed (1 knife finishing)

Jointing a 4 knife block and increasing the feed speed to (4x12) ie: 48M/min gives the same resulting pitch (finish).

Jointing can be carried out on straight planing blocks - 'straight' jointing, and on profile blocks - 'plunge' jointing.

The process of jointing, which can be repeated several times, produces a heel on the knives. In the interests of quality this must not be allowed to exceed a certain width. This is approx 0.5mm on softwood and 0.7mm on hardwood (see Fig 5).

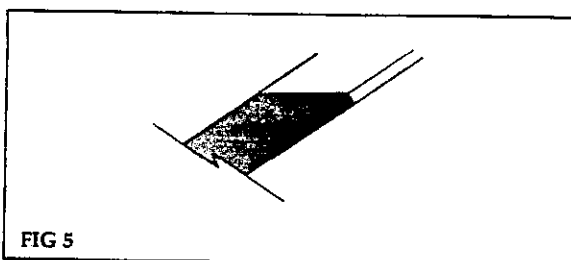

Both high speed steel and carbide knives may be jointed but require a different composition of jointing stone.

An alternative method of increasing output is to increase the spindle speed thus permitting a

faster feed speed for a given quality of surface finish. 'Wadkin' can offer alternative spindle speeds up to a maximum of 15000 rpm. This highest spindle speed, achieved with very high precision, lubricated for life bearings, permits a 2 1/2 x (250%) increase in output without jointing.

Typical surface finish pitch values for different applications are listed:

Sawmilling	1.5 to 2.5mm
Joinery	1.5 to 2.0mm
Strip moulding	1.3 to 2.0mm
Furniture	1.0 to 1.5mm

Machine Feed Systems

Push Feed (Fig 6)

This original method of feeding a planing and moulding machine is still provided, and consists of two top driven and two opposed bottom driven feed rolls at the infeed end of the machine. An idle roller and pad pressures between the cutterheads controls the timber down to the bed and across to the fence as it passes through the machine. It follows that if bowed or twisted stock is fed to the cutters, that while a perfect profile will be produced, the component will be as twisted or bowed as it entered.

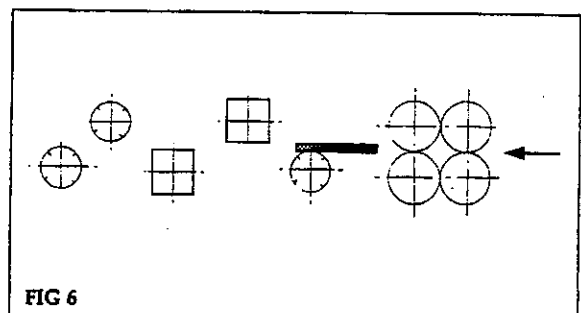

The pushfeed machine has the disadvantage that the last piece of timber is always left in the machine; traction stops as the trailing end leaves the feedworks. The last piece can only be retrieved by following with a scrap length or by reverse feeding, in which case the component is unfinished.

Through feed (fig 7)

Through feed was developed to overcome the handicap of the last piece remaining in cut, and to eliminate the heavy top and side pressures.

Drive rolls between each cutterhead feed the components through the machine.

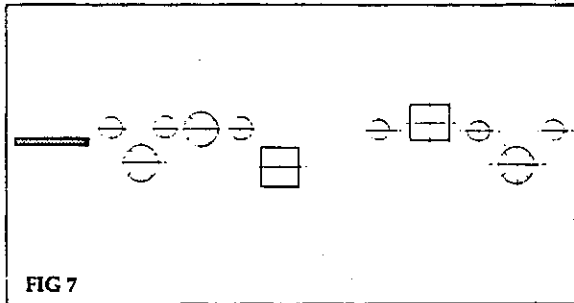

A long infeed table before the first bottom head, together with the much lighter loading on the timber, enables straightening of the component i.e. the underside being straightened (surfaced) at the first bottom head, and the edge (fence side) being straightened at the first side head (see Fig 8).

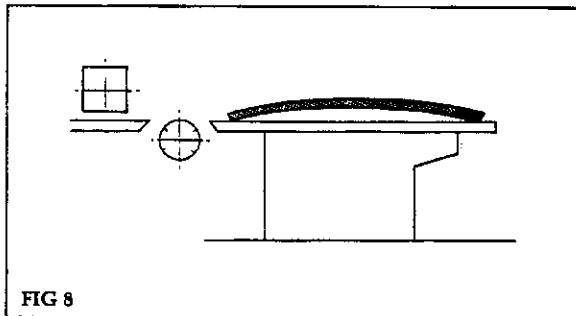

An alternative method of straightening combines underside and fence side straightening, using a single cutterblock, planing the underside in the normal way and machining a reference edge with a rebating disc on the same block (see Fig 9).

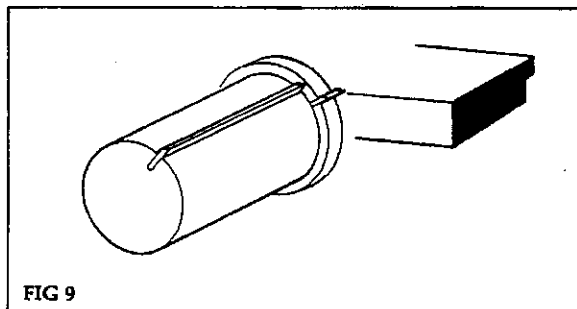

The above straightening techniques are most successful on timber which is bowed and has square ends, typical of softwood. For timber which is twisted and has out-of-square ends, typical of some hardwoods, an alternative technique is provided.

Grooved bed straightening (Fig 10)

In this design, grooving cutters on the first bottom head permit support in the form of rails right through the cut, thus preventing 'dipping in' on the twisted timber, or 'buckling' as out-of-square ends come into contact with each other. The grooves on the underside are subsequently machined out on a second bottom head, which is obligatory. Fitting a standard lip plate and cutterblock converts the machine to conventional use.

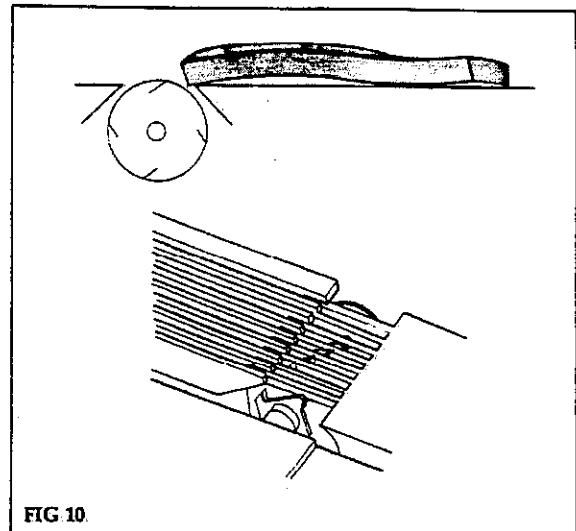

Hopper Feeding (Fig 11)

To enable the operator to feed timber at relatively fast feed speeds and still maintain butt-up, (this may be difficult on short lengths), various types of hopper feed are available.

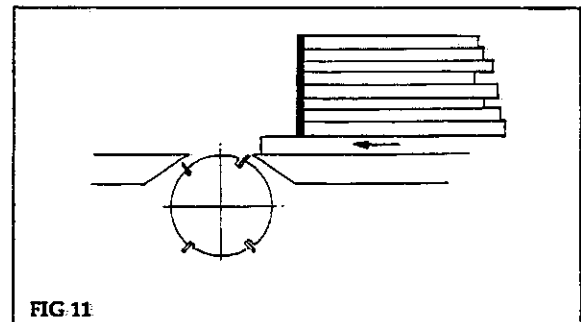

Components are stacked in a hopper at the infeed end of the machine and automatically fed one at a time from the bottom of the stack at a rate to ensure 'butt-up'. A slipping device prevents the hopper feed trying to override the machine feed.

Feeding at very high feed speeds, typically on flooring, cladding etc, also presents problems to the operator, again a special feeding device (fast feed table Fig 12) can be provided.

The fast feed table, in line with the machine feed, receives timber from a tilt hoist and cross chains, the driven rollers in the fast feed table and an overhead hydraulically driven nip roll ensure 'butt up' before entry into the machine feedworks, a slipping arrangement prevents overriding.

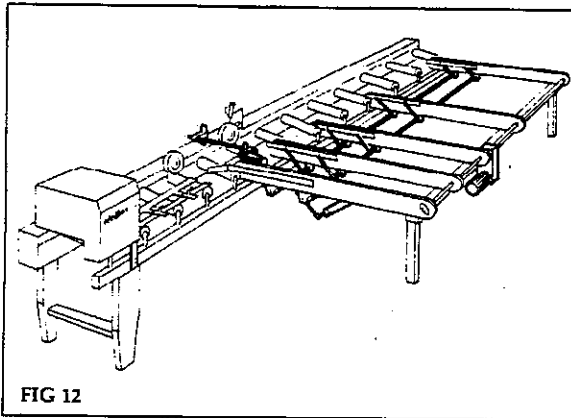

FIG 12

Outfeed Equipment

Generally used on highfeed speed machines, this equipment can be provided at the outfeed end of 'Wadkin' moulders to transfer to another process, ie: stack, bundle, wrap, count, etc. Outfeed equipment can be provided and programmed to print on each component some identifying information. eg. Job No. Date, etc. Combinations of these facilities enable the finished components to be presented in a variety of ways at the outfeed end of the machine.

Extra Head Positions

Typically a planing and moulding machine has four heads to machine all four faces, these can be augmented with the addition of other heads. The most common is a second bottom head to ensure clean up on the underside. Where the amount of timber to be removed is great, or where the mould

detail is complex it may be necessary to provide an extra bottom head, available as an option.

Splitting (Fig 13)

Splitting is a common operation, usually done on the last bottom head, and often requiring very large horse powers. Such a head is available and may be fitted with anti kick-back fingers to prevent ejection towards the operator. Only one saw can be fitted on the smaller machines, ie. GC.

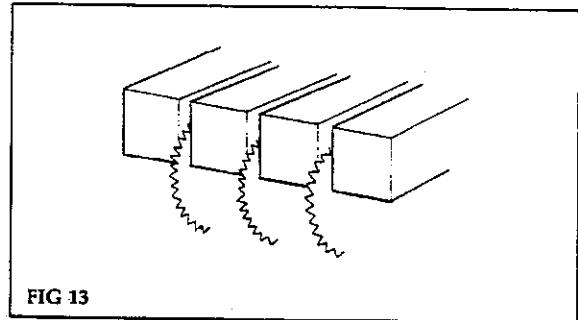

FIG 13

Universal Head

A universal head, either three or four position (always last head on the machine) can be provided to order, or the machine prepared to fit the head at a later date. The three position head may be used as a top head, bottom head or near side head and at any angular position in between. The four position head has the added capability of use as a fence side head.

The universal head gives greater flexibility for splitting and moulding on a conventional machine, and special pressures, chipbreakers, etc can be provided to ensure perfect control of the workpiece.

Dial-a-Size Positioning (Fig 14)

On machines which are used for a large variety of small quantity batches of square dressed material, the set up time can be reduced by fitting Dial-a-Size positioning.

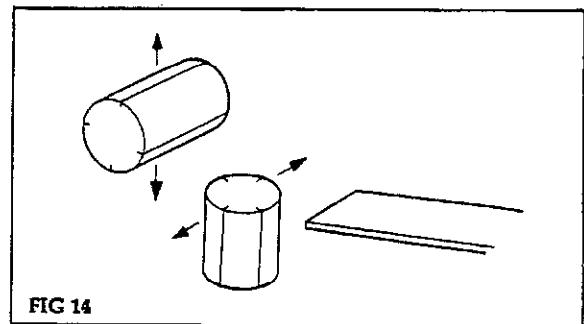

FIG 14

The near side head horizontal adjustment is motorised and fitted with an encoder, the motorised vertical movement of the top head and feed is also fitted with an encoder.

A programmable memory stores the widths and thicknesses of the workpieces to be produced, and on command the two heads are repositioned to the preset dimensions. In a similar manner, where components of random width are machined (eg. Table tops, see Fig 15)

The machine can be arranged to sense the width of the incoming pieces and automatically move the outside head to the required position.

Whilst being a slow operation, (butt feeding is not possible and the feed speed is slow), the facility does have great advantage to some users.

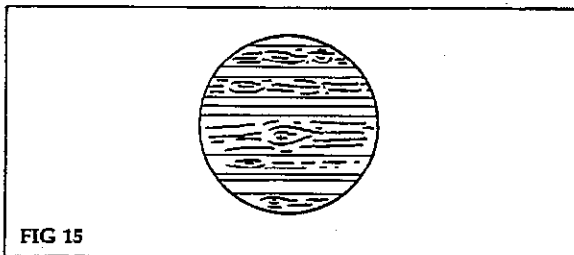

Feed Enhancement

The 'Wadkin' push feed and through feed systems are the result of years of experience in the planing and moulding industry, and for the great majority of work are exemplary. However, the great variety of timbers available, and the different conditions in which they are presented to the machine is acknowledged in the various options available to enhance feeding and minimise bed wear.

Bed lubrication

A lubricant is introduced to the surface of the machine bed, from a manual or auto pump; this reduces friction, improves feeding capability and reduces bed wear.

An alternative; of introducing air between the timber and the bed of the machine, can be provided for those machines that do not have a second bottom head to machine off the small amount of oil introduced to the underside of the timber, or where the material being machined must not in any circumstances be contaminated with oil.

Feed rolls

The top driven feed rolls of a through feed moulder are normally spring loaded down onto the workpiece. The required amount of load can vary with the nature of the work being run, although as a general rule it must be as light as practicable, and variation in rough timber thickness will of course increase the load as the feed rolls yield more. Adjustment of the loading is done at each individual roll.

Pneumatic loading can be provided; this has a number of advantages. The loading does not vary with any variation in lift, and the amount of loading can be changed more easily, using an air regulator valve.

One regulator controls the loading to rolls before the top head, and the other regulator controls the rolls after to top head.

Noise



Planing and moulding machines, by virtue of the number of cutter heads and the speed of the heads, produce high noise levels, typically between 95dB and 115dB when cutting.

The woodworking machine regulations require that an operator is not to be subjected to noise levels above 90dBA for 8 hours, some precautions are therefore required and a safety/ acoustic cover can be supplied for this purpose.

It should be noted however, that even with a sound enclosure, under some circumstances, because of 'break out' (at say the infeed end), the noise level at the operating positions will be above 90 dBA.

For personal safety reasons the operator should wear ear defenders.

WARNING Before operating the machine read the Preface and Notice to Operators in section 3, Operating Instructions.



LEADING PARTICULARS

Principal dimensions and capacities of Super XJS220

Maximum size of timber admitted	230mm x 130mm
Maximum size of finished timber	220mm x 120mm thick
Minimum size of finished timber	15mm x 6mm thick
Feed speed infinitely variable	10-120 meters per min
Pressure adjustment of feed rolls	6 bar (reduced)
Limit switch at the extremities of the rise fall beam.	
Feed rolls on each infeed shaft (pushfeed)	3 x (42mm wide x 186mm dia.) serrated rollers.
Feed rolls at each throughfeed station (shaft mounted)	3 x (50mm wide x 140mm dia)
Feed rolls at each throughfeed station (flange mounted)	2 x (20 wide x 140mm dia.), 1 x (40 wide x 140mm dia.) Serrated or polyurethane rolls + spacers
Driven table rollers	220 wide x 140mm dia. plain steel roll.
Diameter of cutter spindles	50mm standard, 1.13/16in or 2.1/8in - options.
Speed of cutter spindles	6000 rpm
Maximum cut of first bottom head	10mm
Maximum cut of first fence side vertical head	10mm



Diameter of cutterblocks

Minimum cutting circle (all heads with dia 40mm spindles)	125mm
Maximum cutting circle top heads	190mm planing 250mm moulding
Maximum cutting circle fence and near side heads	190mm planing, 205mm moulding (up to 15mm below bed level).
Maximum cutting circle bottom heads	190mm planing 250mm moulding 180mm planing (first bottom)

Unit G

Maximum saw size	400mm
Minimum saw size	250mm
Sleeve size	3 1/4" O/D x 50mm I/D x 240mm long opposed double key drive 3/8" wide

Output of motors

Feed motor (hydraulic)	30kw (40hp)
Rise and fall motor	1.1kw (1 1/2hp)
Spindle motors	
All heads - standard	5.5kw (75hp)
All heads - options	7.5kw (10hp), 11kw (15hp), 15kw (20hp), 18.75kw (25hp)
Horizontal heads only - options	22.5kw (30hp)
Splitting unit motors - options	18.75kw (25hp), 22.5kw (30hp), 30kw (40hp) 37.5kw (50hp) 45kw (60hp), 55kw (75hp), 75kw (110hp)



SECTION 2 LIFTING AND TRANSPORTATION

Unloading

Verify the weight of the machine (see **Installation Data**). Ensure that all lifting equipment used is capable of lifting this weight as a minimum.

To lift the machine, place two 55mm diameter steel rods 1.5 meters long in the holes provided in the machine feet.

Carefully place slings of suitable capacity on the crane hook. The angle between the slings not to exceed 90 degrees. Keep these as wide apart as possible by inserting wooden chocks between the machine body and the slings to avoid damage. Locate the slings securely on the steel rods.

Moving

In the process of moving, avoid jolting or vibrating the machine. If the ground is flat the machine can be positioned on wooden plinths and moved by rollers instead of lifting.

IMPORTANT: When lifting, the machine has a tendency to tilt backwards (towards the electric motors and the motor mounting brackets). Allowance should be made for this in positioning.

Unpacking

Undo the packing and make sure that damage has not occurred during transit; undo the case of accessories and ascertain that the machine is complete with all fittings.

Cleaning

Before levelling the machine, carefully remove the anti-rust material particularly from the bright parts.

Clean the machine with paraffin or diesel and a soft rag. Do not use a substitute - it may precipitate an explosion.

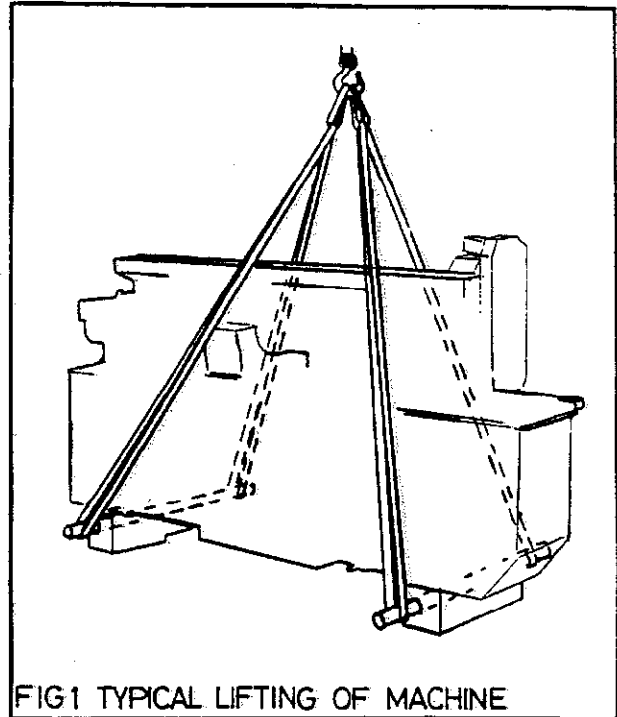



SECTION 3 INSTALLATION DATA

Major Dimensions and Weight

Machine Dimensions and Weights

Maximum length	6200mm
Maximum width	2200mm
Maximum height	1700mm
Weight	7000kg

Locations and Foundations

To obtain the best result from the 'Wadkin' woodworking machine it is important that the floor on which the machine is to stand has been prepared and is dry. Level the machine from the middle of the bed between the adjustable screw supports with the aid of a spirit level. Place the steel plates supplied with the machine under the adjustable levelling screws.

Suggested levelling aids:

Straight edge 2 metres long
Feelers (thickness gauges), 0.50, 0.10, 0.15 and 0.2mm.
Engineer's spirit level.

Levelling longitudinally

Place the spirit level on the table and moving the level lengthwise check any variation. Adjust machine level by use of the adjustment screws in the feet of the machine. Deviation should not be more than 0.2mm.

The straightening table (i.e. table before the first bottom head), should be in line with the table after the first bottom head. Maximum tolerance is 0.1mm in 1600mm.

Levelling transversely

Place the spirit level across the table at right angles to the fence and repeat this section at intervals of 800mm. Total variation at each position should not exceed 0.1mm.

The foundations

The size of the foundations depends upon the specific machine model, format of the heads and disposition of the exhaust outlets and will be provided for individual machines.

If the floor consists of 100mm - 150mm (4 to 6 inches) solid concrete, no special foundation is necessary. M12 'HILTI' type holding down bolts (not supplied with the machine) can be used to secure the machine to the floor.

Note: THE MACHINE MUST BE BOLTED DOWN BEFORE USE.

See foundation plan for details of floor area required.

Supplies and services.

Electrical supply

The customer is responsible for an adequate electrical supply. Details of power requirements are provided with the machine.

The machine is delivered with its complete electrical equipment ready for connection.

The electrical connection and schematic diagram are found in the electrical control cubicle of the machine. All that is required is to connect the power supply to the disconnect (isolator) switch at the electrical control cubicle or panel.



POINTS TO NOTE WHEN CONNECTING THE POWER SUPPLY.

Check the voltage, phase and frequency correspond with those on the machines nameplate details.

Check the main fuses are of the correct capacity in accordance with the machine nameplate details.

Connect the incoming supply of leads to the appropriate terminals.

Check all connections are sound and that equipment is earthed.

Check the spindle rotation is correct. When looking from the front of the machine the feed rolls should rotate in a clockwise direction. To reverse the rotation on any drive, reverse any two of the lead connections at the incoming supply.

IMPORTANT:
ANY ELECTRICAL MODIFICATIONS SHOULD BE CARRIED OUT BY A COMPETENT ELECTRICIAN.

Pneumatic pressure equipment (where fitted).

To make the system operative connect up the air pipes and fittings to a suitable air supply.

The size of the air inlet connection is 1/4in BSP female.

The size of the air pipe is 8mm O/D x 5mm I/D.

Pressure required is 6 bar (approximately 90 PSI), see **Operating Instructions** for feedroll pressures.

The air consumption is approximately 200 cu.dm/hr (7 cu. feet/hr).

Exhaust (Dust Extraction) Connection.

The size of the connections are given on the Foundation and Dust Extraction Plan.

The part of the air extraction pipe fitted to the exhaust hood should be flexible and detachable. The length of the flexible part is dependant on the way the pipe is used and the adjustment required on the work spindle. As a guide use a flexible pipe one metre long for the lower and fence side spindles and two metres for the top and near side spindles.

The flow of air to the exhaust hoods should be approximately 25 to 30 metres per second.

Volume of Air Required.

For bottom heads

51-54 cu.metres/min.
(1800-1900 cu.ft/min.)

For fence and near side heads

27-30 cu.metres/min.
(953-1053 cu./F/min.)

For top heads

37-40 cu. metres/min.
(1305-1411 cu.ft/min)

The total volume of air required for the Dust Extraction is directly related to the total number of spindles.

Schematic Diagram for Electrical Services

The electrical wiring and schematic diagram will be in the electrical control cubicle of the machine.



SECTION 4 GENERAL OPERATING INSTRUCTIONS

Safety

The safe operation of woodworking machinery requires constant alertness and close attention to the work in hand.

Read this Instruction manual, the Preface, and Safety Notes carefully before operating the machine.

Blunt cutters often contribute to accidents. An efficient machinist knows when sharpening is necessary, but if there is reluctance to spend time on grinding and resetting, the cutters may run beyond their efficient limits and instead of cutting efficiently and smoothly they will tend to chop and snatch at the workpiece. This not only increases the risk of accidents but also lowers the quality of work.

Customers are strongly advised at all times to use high tensile cutterblock bolts which should be tensioned by means of a torque spanner. When choosing cutterblocks ensure they are suitable for the minimum cutting speed of the machine.

It is recommended that personnel involved with the machine are acquainted with the Woodworking Machines Regulations 1974 and also booklet NO. 41 'Safety in the use of woodworking machines' issued by the Department of Employment and available from Her Majesty's Stationary Office. Also BSI Code of Practice 'Safeguarding Woodworking Machines' Part 1 BS 6854.

Safety Devices

The safety covers and dust hoods must be closed during the time the machine is running. Cover the non-used part of the cutterblocks with the guards provided.

Only remove the feed roller guard when changing rollers and with spindles switched off at the control panel.

Spindles which are run in two directions (ie: Universal Head), should be fitted with a locking collar to prevent unforeseen unlocking on mode changeover.

Do not work spindles if the spindle nuts or intermediate collars are not securely tightened.

Only remove fitted covers from the drive belt housing when changing or retensioning belts. The drive spindle must be stationary before making any adjustments.

WARNINGS

Notice to operators

Read and follow the guide-lines given in Safeguarding Machines and Safety Notes which are repeated on the front of the machine.

Before operating the machine.

Ensure that all guards and fences are securely fitted and correctly adjusted. Guards and other safety devices are NOT to be removed while the machine is in operation. They are there for YOUR SAFETY.

Ensure cutters/blades are the correct type and rotate in correct direction of cut, are sharp and securely fastened.

Cutter equipment is suitable for machine spindle speed.

Remove or fasten loose clothing; confine long hair and remove jewellery, etc.

Ensure sufficient working space is provided and that lighting is adequate.

Switch on all dust extraction equipment, ensure it is working correctly.

During Machining

Wear suitable protective equipment, e.g. goggles, ear defenders, dust mask.

Stop the machine before making adjustments or cleaning woodchips from the working area.



Keep the floor area around the machine clean and free from wood refuse.

Do not allow the floor to become slippery with oil or grease.

Report any machine malfunction or operator hazard to a person in authority immediately. Do not attempt to repair the machine unless qualified to do so.

Ensure all power sources are isolated before commencing any maintenance work.

Comply with the Woodworking Machines regulations. Failure to do so could result in legal proceedings.

Machine Controls

Before starting the machine, operators should familiarise themselves with the various controls and their usage.

Check direction of spindle, rotation ensuring that the spindles rotate freely. Check each spindle motor separately.

Check the infeed table raise and lower operation (if adjustable).

The machine has continuous feedworks. When started, timber stock will be fed to the cutter heads until the pass is completed or the machine is stopped. The feed speed is variable and can be adjusted by a control dial on the panel, to give speeds throughout the machine range.

The feed rolls are rubber covered and should be adjusted to 1mm lower than the workpiece.

The height of the feedroll adjustment is indicated by the graduated scale on the panel above the infeed roll cover. Adjustment of the feed rolls is made by pressing the pushbuttons marked:

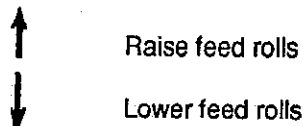

Note: The powered vertical adjustment of the beam is electrically interlocked with the Top head and cannot move until the hydraulic locks are disengaged.

The pushbuttons are positioned on the Electrical Control Panel located at the infeed end of the machine and also at control stations located at various points on the machine, depending on modular construction.

The adjustment for height of the intermediate rubber covered (plain) rolls may be made independently to suit the finished workpiece.

The panel mounted control station at the infeed end of the machine may contain the following features.

- 1) START - STOP pushbutton with indicator light for each spindle. Buttons numbered from infeed end.
- 2) FEED START
- 3) FEED STOP
- 4) RAISE - LOWER pushbutton for beam adjustment.
- 5) MASTER STOP (emergency) button with indicator light.
- 6) CLAMP ON/OFF push button for hydraulic locking of top head vertical movement.
- 7) HYDRAULIC PUMP ON pushbutton. This initialises pump for hydraulic drive. It can only be switched off at either master stop or main power button.
- 8) INDEPENDENT/TRANSFER switch for machine use in a line or for independent use.
- 9) WARNING LIGHT for feed speed. If illuminated the feed will stop (see FAULT FINDING).
- 10) FORWARD - REVERSE (inch) pushbutton used for setting.
- 11) VARIABLE FEED SPEED CONTROL with readout.
- 12) MOTOR BRAKING pushbutton where brake motors are fitted this releases brake when motor is stationary.



GENERAL OPERATING INSTRUCTIONS

13) OIL ON/OFF switch only for automatic bed lubrication. Oil is not pumped until machine is running.

14) LOW OIL WARNING

15) MAIN POWER ON/OFF pushbutton.

16) MOTOR OVERLOAD WARNING when illuminated indicates a motor has tripped and is 'running down'.

17) WOOD METERAGE COUNTER the bottom right hand meter records total meters through machine. The top left hand meter indicates the amount of timber machined of a particular run. The middle left hand meter indicates the required amount of timber to be machined in a run. This figure is set by pressing the white lever down (bottom left hand corner) and then pressing the relevant button under each unit counter to advance/retard the figure displayed.

At the end of a run the feed rollers will stop. To restart zero the top left hand counter, reset (if required) the 'run' length and then press the feed start pushbutton.

18) AMPERAGE METER for splitting saws.

The motor rating on the splitting saw is 67 amps and the feed speed should be adjusted so as not to exceed this value when splitting.

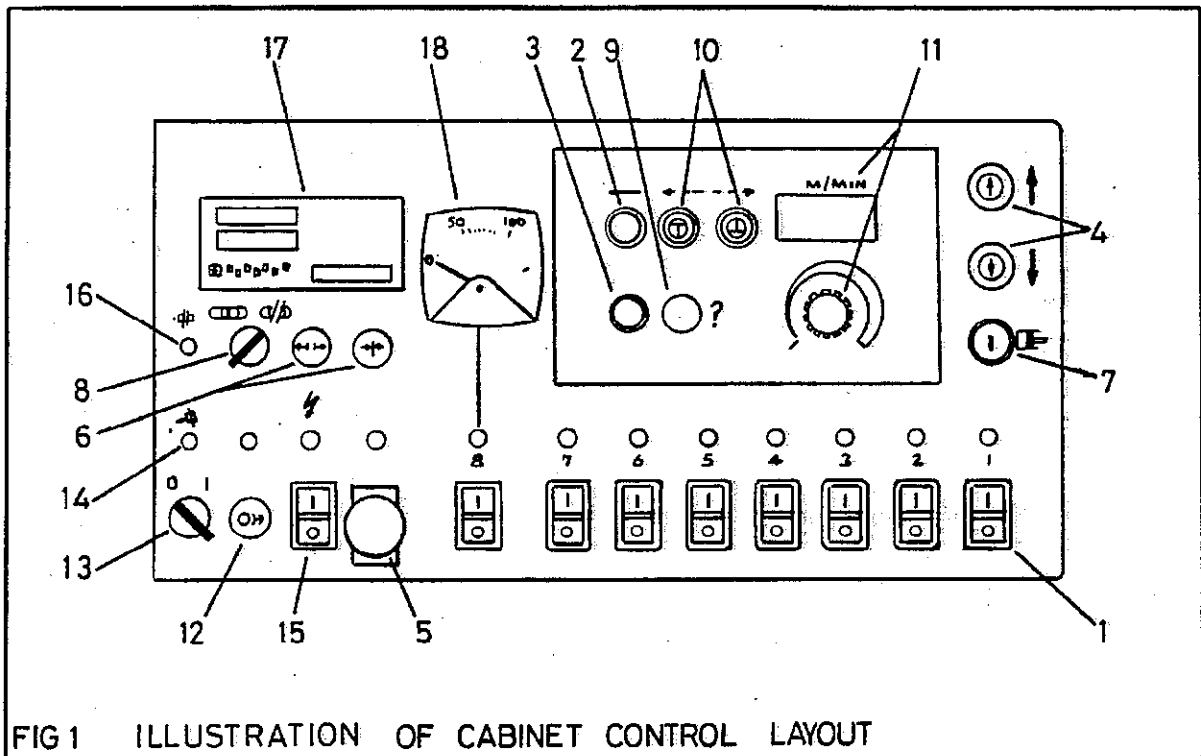

FIG 1 ILLUSTRATION OF CABINET CONTROL LAYOUT



Dial-a-Size Electronic Positioning to Near Side Head and Top Head

The powered traverse movement to the near side head is by a 'KEMO' geared motor.

The traverse movements of the heads are each connected to an 'encoder' which sends pulse signals to its respective 'Elgo' digital read out controller situated in the main control panel.

The traverse of the heads reacts to data put into the 'Elgo' controller which displays the cutterblock position in relation to its datum face. The datum face for the near side head is the fence. Datum for the top head is the bedplate.

The head traverse movements may be hand or power operated and a switch is provided for this purpose.

Setting Up

All setting parameters are available via the front keypad. Programming is inhibited until a link at the back of the unit is opened.

The programming link is in the form of a two terminal plug-in block, with a shorting wire. Unplug to set in parameters. Reinsert plug to operate.

Note: The controller will not run with the link open.

Setting of the parameters is achieved as follows:-

- 1) Press T, top display extinguishes and 'CH' is displayed. This ensures that the operator knows when the T button has been depressed (even by accident).

- 2) Enter [T] functions [1].....[5], 'CH' is extinguished. Title name is displayed in top window; value of parameter is displayed in bottom window.
- 3) Press C to clear existing value, enter required value.
- 4) Press T again to revert to operating mode.

The [T] functions/parameters are as follows:-

- [1] This sets the slowdown point during approach to position. 'SLSP' is displayed.
- [2] This sets the stop correction offset. 'COR' is displayed.
- [3] Saw width compensation is entered. 'SABL' is displayed.
- [4] Time at standstill during backlash over-run and delay in drop-off of 'In Position' relay after drive stop is initiated.

'Ti' is displayed. Time can be set from 00.0 to 15.9 seconds. Also sets the auto retract time (i.e., distance).

- [5] This sets the decimal point in the displays. 'DP' is displayed.
 - 1:- means units only (i.e., no decimal point).
 - 2:- means tenths displayed (i.e., one decimal place 0.0)
 - 3:- means hundreds displayed (i.e., two decimal places 0.00).

One [T] function is available with programme link either open or closed. That is Inch/Metric selection. This is used as follows:

- (1) Press [T], 'CH' appears in display.
- (2) Press [O], 'inch' or 'mm' appears in display.
- (3) Press [C] to changeover.
- (4) Press [T] to revert to operation.

The decimal point is automatically moved and any actual value correctly recalculated. The set up parameters are also in the chosen units.

When [T] is pressed inadvertently, 'CH' is displayed

to warn operator that he has pressed the button. Simply pressing [T] again returns controller to operating mode.

Note: All these parameters will be preset by Wadkin during the setting-up of the machine.

Method of Operation

To Set Datum

- 1) Switch to 'Hand' operation (Fig 2).

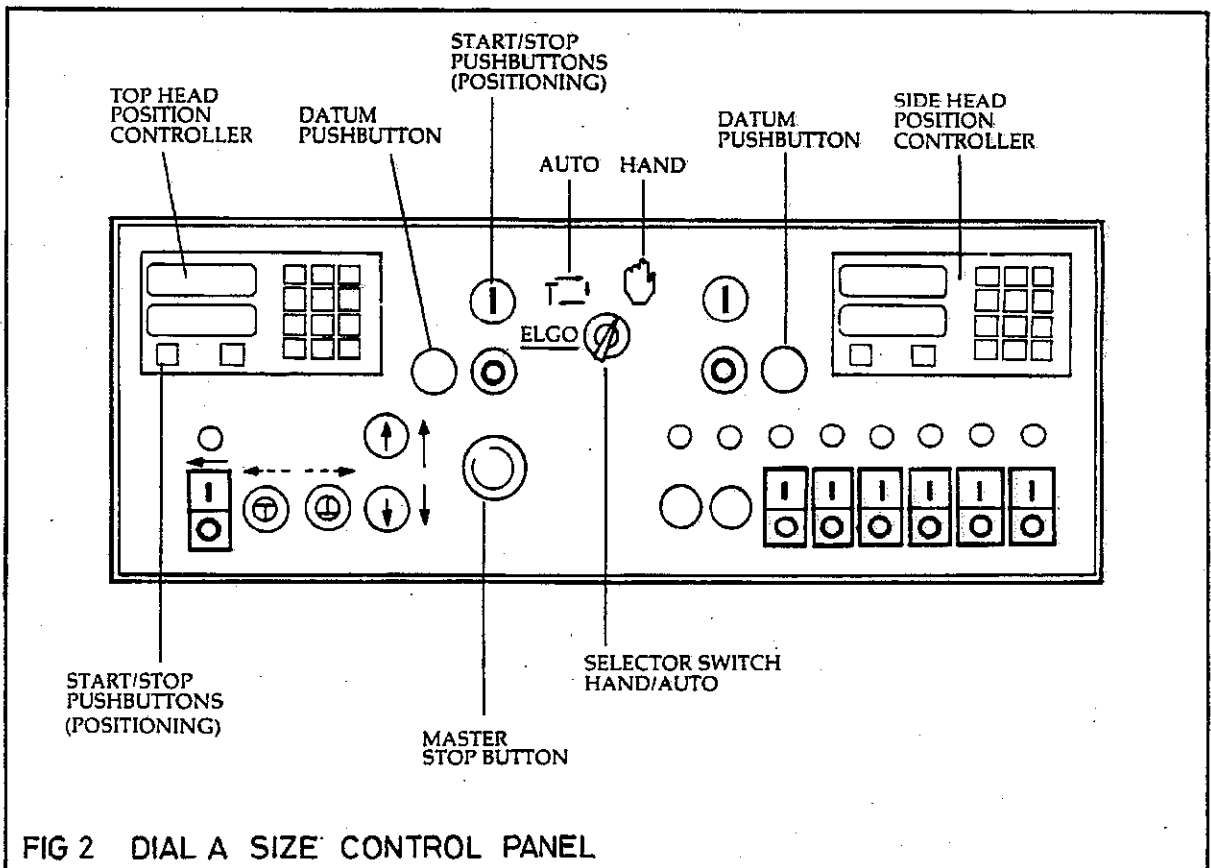

FIG 2 DIAL A SIZE CONTROL PANEL



- 2) Determine the distance between the cutterblock and either the fence or bedplate, by use of a known thickness setting block or piece of timber; by hand winding the spindle up to the setting block.
- 3) Enter this figure using the keypad.
- 4) Press Datum pushbutton (Blue) on control panel.

These figures will be displayed on the demand value display (bottom window). The Datum figure is now set.

Note: (a) These Datum figures need only be re-set at machine switch-on, or if the cutterblocks are changed.

Note: (b) To hand set the height of the top horizontal spindle independently of the beam, disengage clutch (i.e., operate power rise/fall lever, (see **Setting Up Machine**)).

To move the heads to a pre-determined position

- 1) Switch to 'Elgo' operation (Fig 2).
- 2) Enter the required position using the keypad.
- 3) Press 'Start' push button.

The head selected will now move automatically to the set position and the figures will be displayed in the actual value display (top window).

- 4) To move to a new position, repeat steps (2) and (3).

Note: The feed can only be inched in this mode.

To run the machine

- 1) Switch to 'Auto' position.
- 2) The feed can now be run continuously, or inched.

99 SETTING PROGRAMMABLE MEMORY POSITIONING

Near Side Head and Top Head

This unit has the capacity to be programmable for ninety-nine positional head settings.

The powered traverse movement to the near side head is by a geared motor.

The traverse movements of the heads are each connected to an 'encoder' which sends pulse signals to its respective digital read out controller situated in the electrical control panel.

The traverse of the heads reacts to data put into the controller which displays the cutter block position in relation to its datum face. The datum face for the near side head is the fence. Datum for the top head is the bedplate.

The head traverse movements may be hand or power operated and a switch is provided for this purpose.

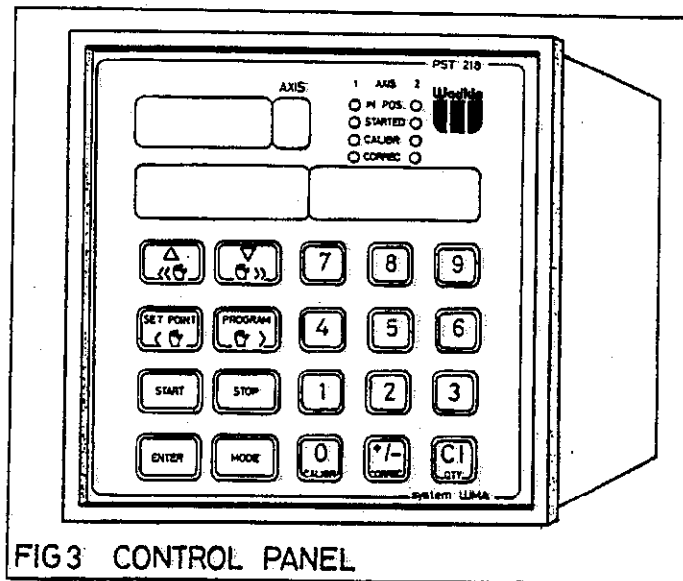

FIG 3 CONTROL PANEL

The illustrations (buttons) on the left hand side of each page show the buttons to be pressed, and in what order.

If buttons are shown with an '&' sign between them, they must then be pressed simultaneously.

POSITIONING

PST 218

SWITCH ON MACHINE

CALIBRATION (Manual)

Each axis must be datumed before production is started.

The calibrating procedures is as follows:

The PST 218 unit can control 2 axes, both of which must be independently datumed.



Push the button until the axis to be datumed (either axis 1 or axis 2) is shown as a number in the LED display

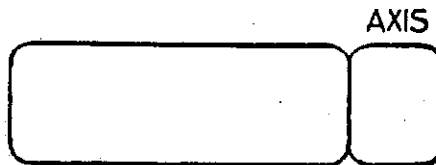

&



The mode and calibration buttons must be pressed simultaneously.

Enter new value.



Press enter.

The axis should now be datumed. Repeat the same operation for the second axis. When both axes have been datumed, the unit is ready for use.

Confirmation is in the top right of the unit where there are LED lights for each axis which represent the calibration.

MANUAL POSITIONING

The axis to be moved must be selected first.



Push the button until the axis to be moved (either axis 1 or axis 2) is shown as a number in the LED display.

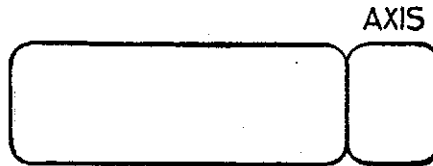

For manual positioning of the unit, the mode key and the direction of travel must be pressed simultaneously.

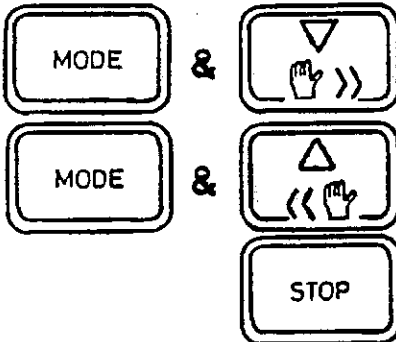

Move to a higher value than the position.

Move to a lower value than the position.

When manual positioning is finished, the stop button must be pressed to put the unit back into the automatic mode.

DIAL-A-SIZE POSITIONING (SET POINTS)

The axis to be moved must be selected first.



Push the button until the axis to be moved (either axis 1 or axis 2) is shown as a number in the LED display.

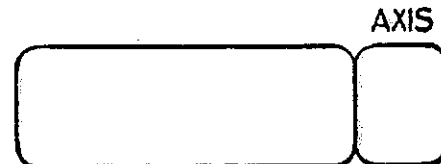

To use the Dial-A-Size option, this is simply a case of pressing the set point button and then the dimension.

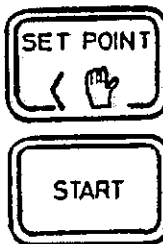

Pressing the 'start' button will send the axis to the position.

When in position, an LED in the top right of the unit will be lit.

Whilst positioning is taking place, the 'started' LED will be lit.

PROGRAM POSITIONING

(For programming of, see later instructions)

CALLING UP PROGRAM

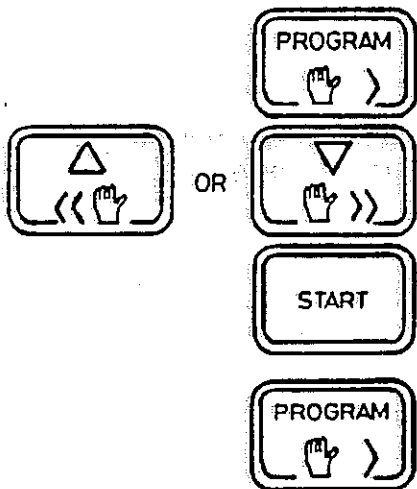

By pressing the 'program' button, the display will change to the program mode.

Pushing either of the two buttons will increase or decrease the program number to the one required.

Pushing the 'start' button will drive the axis to the position stated in the program.

NOTE: To escape from the program mode of the unit, press the 'program' button.

When the axis is in position, the 'in position' LED will be illuminated in the top right of the unit.

PROGRAMMING OF THE UNIT

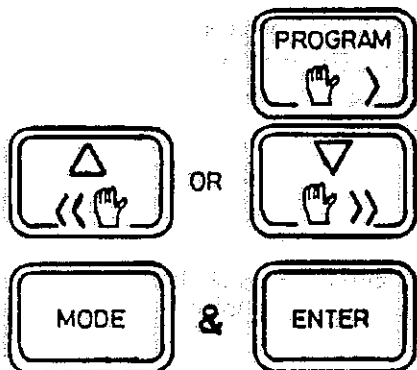

By pressing the 'program' button, the display will change to the program mode.

Push either of the two buttons until the program number required to be programmed is found.

The buttons 'mode' and 'enter' when pressed simultaneously will enable you to have the access to the program number that is illustrated in the display.

You will now have access to the axis.

Enter the required figures if a new number or alteration.

NOTE: If the figures for axis 1 are correct and it is only axis 2 which has to be altered, press 'ENTER' without altering any figures to give access to axis 2.



Pushing the 'enter' button will enter the figures into the memory and give you access to axis 2.

Enter the required figures.



Pressing the 'enter' button will enter the new figures into the memory.

The unit is now ready for use as 'calling up program'.



NOTE: Program P O is only for test purposes.

To clear existing information, press 'CL Qty' before entering new figures.

TO USE THE RADIUS OFF-SET FEATURE

CALIBRATION (MANUAL)

The centre of both the left hand and top head spindle must be calibrated to use the off-set feature.

Each axis must be datumed before production is started.

NOTE: Maximum travel limit parameters may require changing. Calibration for using radius off-set is as follows:



Push button until the axis to be datumed (either axis 1 or axis 2) is shown as a number in the LED display.

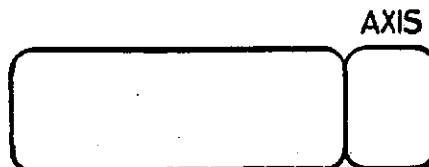

OPERATING INSTRUCTIONS



&



The mode and calibration buttons must be pressed simultaneously.

Enter the distance from the centre of the spindle to the bed, or fence, depending which axis is being calibrated.



Press enter

The axis should now be datumed, repeat the same operation for the second axis. When both axis have been datumed, the unit is ready for use.

Confirmation is in the top right hand of the unit where there are LED lights for each axis, which represents the calibration.

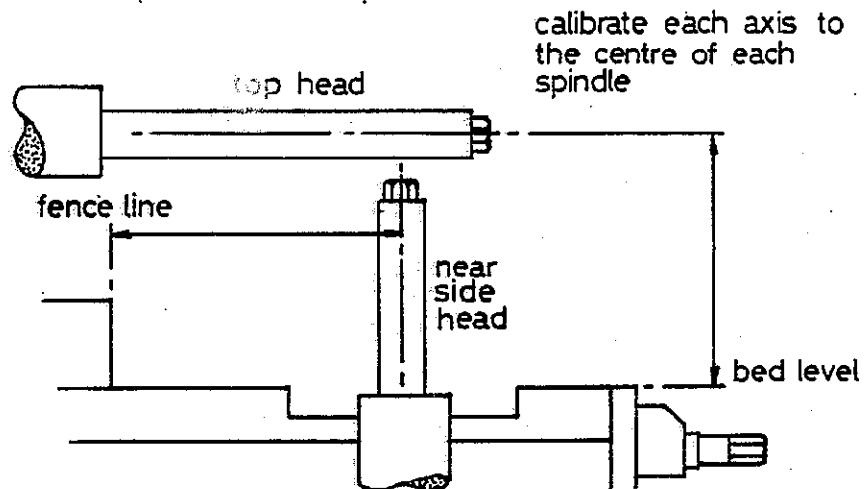



OPERATING INSTRUCTIONS

To enter the radius off-set

Measure and record the radius of the cutterheads to be used.

Push the button until the axis to be off-set (either axis 1 or axis 2) is shown as a number in the Led display.

The 'Mode' and 'Correct' buttons must be pressed simultaneously.

Enter radius value of the cutterhead for that particular axis.

Press 'Enter' twice.

Repeat the same procedure for the second axis.

When both axis have had the radius off-sets entered, the unit can be used as 'calling up a program'.

When the heads are moving into their programmed positions and, when they are in position, the display will show the relevant position of the centre of the spindle.

To display the actual 'finished' size positions, of the cutterheads, push the 'program' button.

OPERATING INSTRUCTIONS



PARAMETER SECTION - To enable the E.S.P. System to function in either Metric (MM) or Imperial (Inches)

PARAMETERS - This section should only be entered into by a competent person, who fully understands their function.

To enter into the parameter section, press 'mode' and '1' then '2' '0' '5'

Imperial
Metric
Axis 1 Axis 2
Axis 1 Axis 2

<u>Decimal Point</u> Display = PA Press '0' to change Press Enter		
<u>Calibration Method</u> Display = PAD Press Enter		
<u>Pre-Switch off Value/Over run</u> Display = PA Press Enter This parameter to correct any positioning error due to "over run"		
<u>Tolerance Value</u> Display = PA Press Enter		
<u>Loop Mode</u> Positioning direction Display = PAb Press Enter		
<u>Loop Value</u> Display = PAb Press Enter		



<u>Delay Time</u> Display = PAde Press Enter		
<u>Minimum Travel Limit</u> Display = PA Press Enter		
<u>Maximum Travel Limit</u> Display = PA Press Enter NOTE: If the radius off-set feature is used then the maximum travel limit should be		
<u>Spindle Factor Counter</u> For Generator Matching Display = PA Press Enter		
<u>Spindle Factor Denominator</u> Display = PA Press Enter		
<u>Conversion (mm - Inch)</u> Display = PA		

Press mode and then Enter to switch from Axis 1 to Axis 2, and go through the same parameters

When finished with both Axis 1 and Axis 2, press Mode and 1 to exit parameter section.



FAULT FINDING

FAULT

Axis will not position accurately.

SOLUTION/CHECK

Check that unit is calibrated (LED top right if unit calibrated), recalibrate if necessary.

Physical object causing an obstruction. Remove object and check overload. Try again.

Movement is greater than the axis limits. Insert new figures.

Negative value in positioning memory.

SECTION 5 HEAVY DUTY PUSH FEED MODULE

General

This unit comprises of four infeed shafts, two above and two below bed level. The gearboxes at the rear driving the shafts, may be hydraulically or mechanically driven. Three serrated steel rollers are fitted to each shaft.

When coupled to the Bottom head module the unit is adjustable in the vertical plane to a maximum of minus 10mm below fixed bed level. Movement in this direction sets the 'cut' on the Bottom head.

Side pressures before and after the feed rolls exert a small force on the timber to keep it in contact with the fence up to the first cutting head.

The standard side pressures are of a skid type design. If the timber is to be 'hand fed' then the first side pressure changes to a 'roller' type to ease feeding. Both types may be operated pneumatically instead of the standard spring pressure.

As a secondary measure to ensure timber is fed parallel and along the fence line, the infeed shafts are pitched. This has the effect of driving the timber not only through the machine but also up to the fence.

An adjustable bedplate with acoustic slotted fingers positioned after the feedrolls, caters for varying cutting circles when the Bottom Head module is fitted. (see **Bedplates and Fences** for further information).

Adjusting Infeed Table Height (Fig 1)

- 1) Release locking handle (1).
- 2) Use the ratchet spanner (2) to adjust the table rise and fall screw. Drive direction of the spanner is adjusted by a lever at the ratchet end.

Adjustment from fixed bed level may be read off the height scale (3).

- 3) After setting re-tighten locking handle (1).

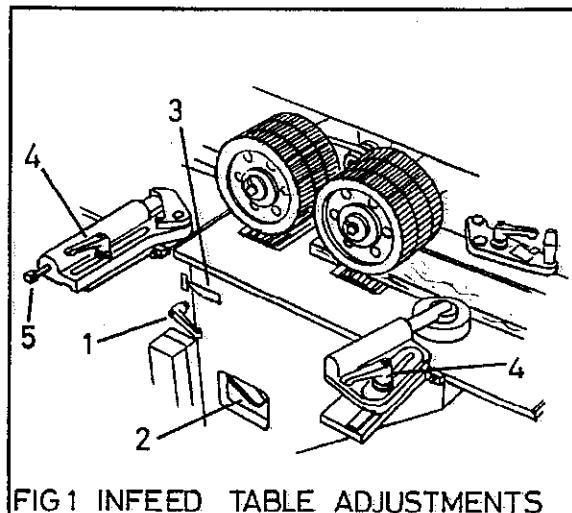

FIG 1 INFEED TABLE ADJUSTMENTS

Adjusting Side Pressure (Fig 1)

- 1) Release locking handle (4) and adjust the side pressure to suit timber width.
- 2) When set re-tighten handle (4).
- 3) Turning screw (5) in a clockwise direction increases the spring tension and stiffens the 'skid' movement. Turned in an anti-clockwise direction the opposite occurs.

Bottom Infeed Roller Adjustments (Fig 2).

The bottom feed rollers have two adjustable stops for maximum and minimum height setting.

Each stop is adjusted by slackening off the locknut (1), adjusting the screw (2) until the desired position of the roller is achieved and then tightening locknut.

- 1) The first infeed roller (3) should be set at 0.6mm above bed level with the air off.

- 2) Place a straight edge (4) across the first infeed roller to the middle of the adjustable bedplate (5) before the First Bottom Head.
- 3) Adjust the second infeed roller (6) until it just touches the bottom of the straight edge.
- 4) The maximum height setting is factory set at 8mm above the bed level but this should be adjusted by the customer to suit the wood type, cut and thickness of timber at time of machining.

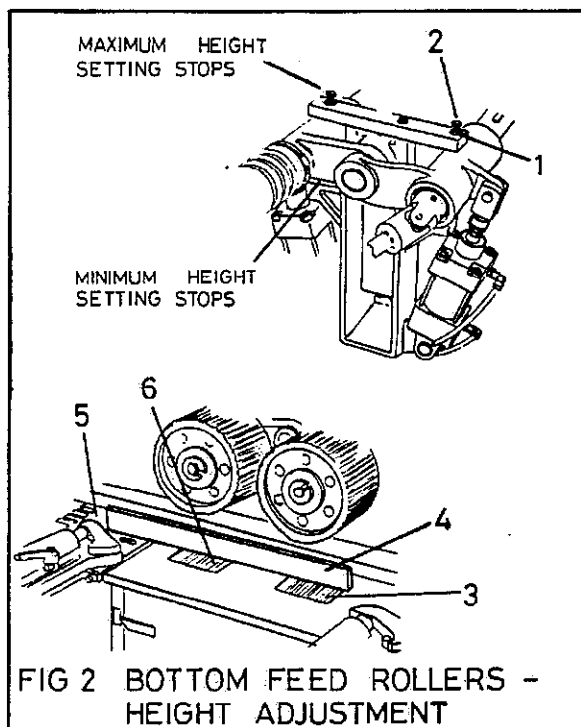

Top Infeed Roller Adjustments (Fig 3).

The top set of infeed rollers are normally set flush with the through feed rollers. They should not normally be adjusted unless when being replaced, maintained etc.

Adjustments are made by:-

- 1) Slackening off locknut (1).
- 2) Place a spanner on the flats of the piston rod (2) near the locknut. Turn either clockwise or anti-clockwise depending on whether the roller needs to be raised or lowered.
- 3) When set re-fasten locknut (1).

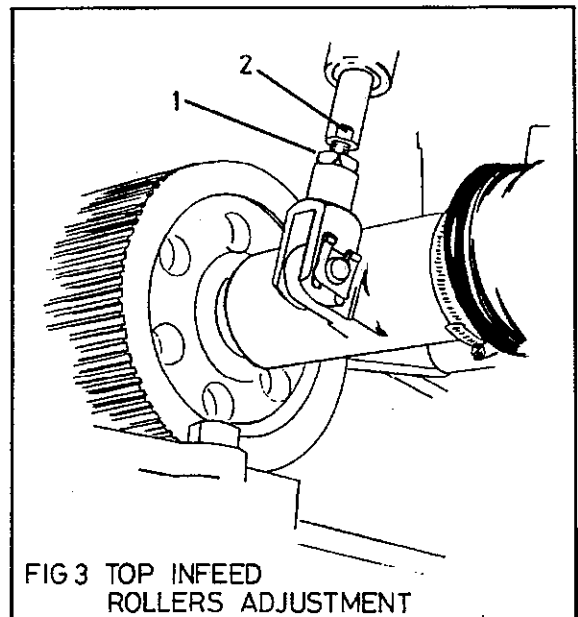

- 5) The pressure to the bottom feedroll may be adjusted using the pressure regulator and its corresponding gauge.

MAINTENANCE

Routine Maintenance

The sideway and the rise and fall screw for the adjustable infeed table should be oiled weekly using Wadkin L4 oil (see **approved lubricants**). Once oiled they should be adjusted through their total movement to ensure even distribution of lubricant and prevent dust build up on slide faces or screw.

Oil points are provided at the front of the machine (Fig 1).

The rear bearings on the feed roller shafts are 'sealed for life' and require no maintenance. However the front needle roller bearings, that carry the main loading, do need greasing at monthly intervals with Wadkin LG grease (see **approved lubricants**).

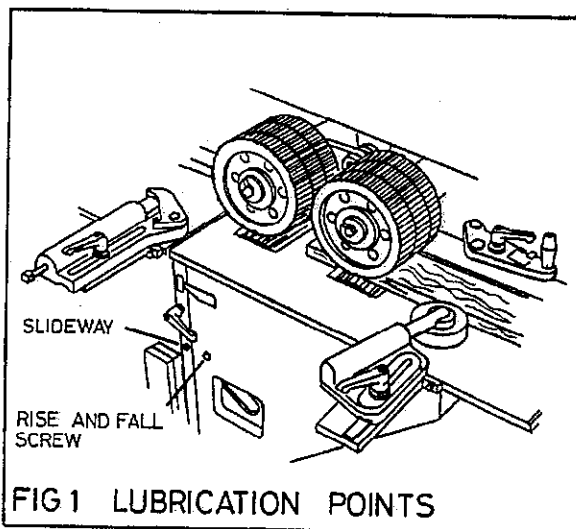

FIG 1 LUBRICATION POINTS

Fluted feed rollers should be cleared weekly with a wire brush.

Changing Feed Rolls (Fig 2)

The feed rolls are shaft mounted with a key location to provide the drive.

The serrated feed rolls may be changed around to even out their wear rate i.e. rollers changed top to bottom, fence side to near side.

Bottom and top rollers are removed in the same manner although the bedplate (4) must be removed to gain access to the bottom rollers (See **Bedplates and Fences** for removing parts).

- 1) Slacken off setscrew (1) a quarter of a turn
- 2) With a soft faced mallet gently tap the rollers to break the clamping adhesion.
- 3) Slacken off the setscrew (1) a further couple of turns and remove 'C' washer (2). The feed roller nearest the 'C' washer should be gently supported by hand whilst doing this.

Note: Serrated rollers have sharp edges and care should be taken when handling them.

- 4) Remove rollers and exchange positions or for new.

When refitting ensure shaft roller bores and rims are clean. Application of a sprayed film of oil onto the shafts not only eases fitting but also helps prevent rollers tightening on shafts, especially where working with wet or resinous timber.

Check rims of rollers 'butt' up to each other.

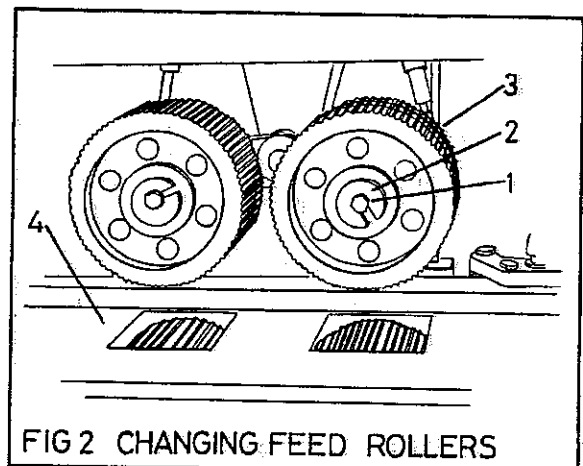

FIG 2 CHANGING FEED ROLLERS

- 5) Supporting outer feed roll replace 'C' washer (2) and tighten screw (1).

Replacing Top Feed Roller Shaft Bearings (Fig 3 and 4)

The bearings may be replaced with the feed roll swings (1) either in situ or by removing a unit as a sub assembly and working on a bench.

To Dismantle a Feed Roll Swing.

- 1) Isolate power at master stop or main isolator.
- 2) Remove serrated feed rolls (see **changing feed rollers**).
- 3) Slacken off jubilee clip screws (2) at either end or the P.V.C. boot (3).
- 4) Push back the boot near the swing (1) to expose the end of the universal coupling (4). Using an allen key remove the grub screw (5) securing the coupling to the feed roll shaft.

Repeat this procedure at the gearbox end.

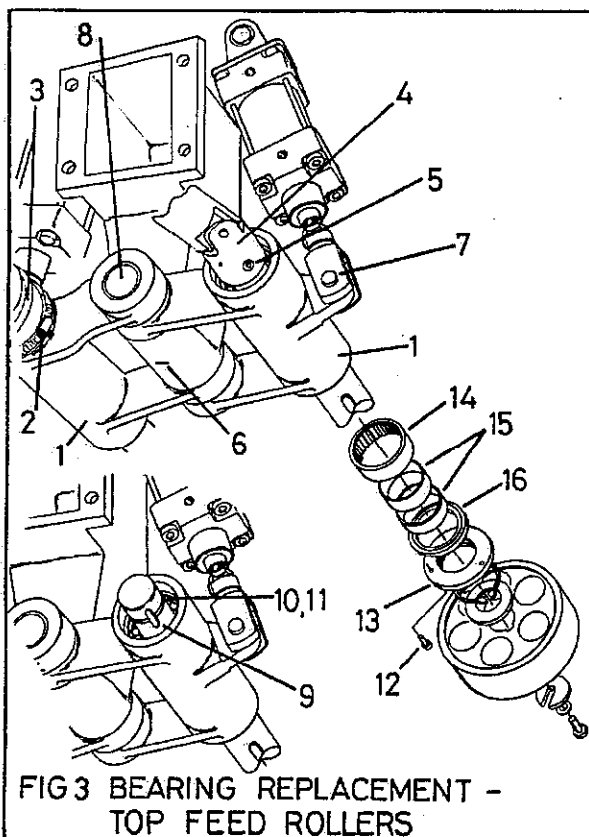

FIG 3 BEARING REPLACEMENT - TOP FEED ROLLERS

- 5) The output shafts of the 'Siti' gearboxes have a 10mm tapped hole in their face. Insert a grub screw and extract the shaft approximately 50mm.

Note: Whilst the shaft is being extracted the universal coupling must be supported to prevent it dropping.

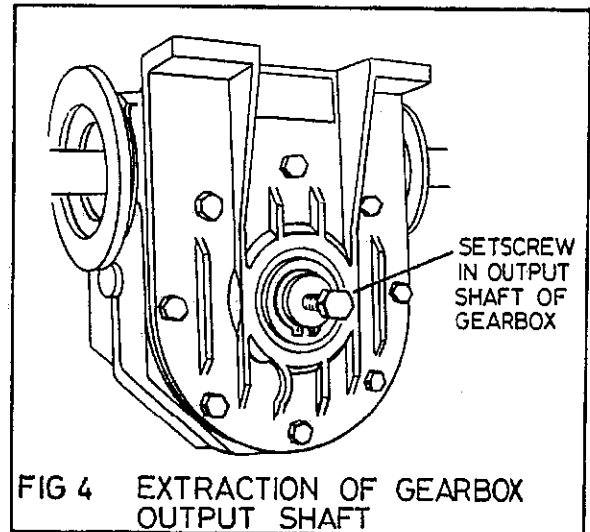

FIG 4 EXTRACTION OF GEARBOX OUTPUT SHAFT

- 6) With the universal coupling (4) free at the gear box end slide off the P.V.C. boot (3). Ease the coupling off the feed roller shaft taking care not to separate the two halves of the coupling.

Follow procedures 7),8),9), and 10) only if removing swing as a unit otherwise go to 11).

- 7) Remove the locking grub screw (6) securing pivot shaft (8).
- 8) Remove pivot pin (7) locating pneumatic cylinder to feed roll swing.

Note: With the pin (7) removed the swing is free to rotate on shaft (8) and therefore to prevent damage the swing should be supported as the pin is being removed.

- 9) Using a suitable driver remove pivot shaft (8) whilst supporting both swings.

- 10) The bushes (17) should be pressed out and then the bores cleaned and de-burred before pressing new bushes in.

When assembling, the left hand swing (when viewed from the rear) should have its cranked arm at the rear most part of the pivot shaft (8).

- 11) Remove key (9) and internal and external circlips (10 and 11).

- 12) Unscrew the three M3 capscrews (12) and remove them and the dust cap (13).

- 13) The feed roll shaft may now be extracted from the front of the machine.

Note: It may be necessary to tap the feed roll shaft from the rear using a soft faced mallet to break the bond between bearing and shaft.

- 14) Using a suitable driver tap the needle bearing out of the front of the swing. By doing this it also removes the seal (16). Care must be taken when removing the bearing not to damage the bores.

- 15) Using a suitable driver then tap the roller bearing out of the rear of the swing again taking care not to damage the bores.

The inner needle bearings rings (fitted to the shaft) are hardened and should not normally need replacing.

Preparation Prior to Reassembly

Ensure shaft and bores are clean and free from burrs.

The rear roller bearing is 'sealed for life' and does not need charging with grease.

Before fitting the new needle roller bearing (15) the protective lubricant must be meticulously removed with petroleum spirit, triethanolamine or other volatile solvent.

In order to prevent the moving parts from being damaged by drying out due to over cleaning, add a small amount of the bearing lubricant to the cleaning agent at the second

bath. The film of grease which remains after the solvent has evaporated will provide protection for the bearing until charged with lubricant.

The new needle bearing should be charged with 'Kluber' lubricant, type 'Isoflex' NBU 15. It is important that the correct amount of grease is applied, preferably using the formula.

$$G \text{ (weight in grams)} = d \times B \times 0.01$$

d = Bore of bearing in mm

B = Width in mm

This is approximately sufficient to fill one third of the bearing volume.

To Re-Assemble:-

- 16) When assembling components reverse the 'strip down' procedure.

When fitting new bearings use 'Loctite 641' on the outer cage (fixture time 5 sec, full cure 3-6 hours)

Care should be taken when fitting new bearings that they 'butt' up to shoulders.

Do not re-use seal (16) always replace with new item. The open face of the seal should face the dust cap.

Replacing Bottom Feed Roller Shaft Bearings (Fig 4 and 5)

The bottom feed roll shafts are only accessible when separate from the machine. Therefore the bottom feed roll swings and mounting bracket are removed as a complete sub assembly.

To Remove Unit as a Sub Assembly

- 1) Position beam at approximately half its maximum travel height and then isolate machine at master stop or main isolator.
- 2) Remove serrated feed rolls (see changing feed rollers).
- 3) Slacken off jubilee clip screws (1) at either end of the P.V.C. boots (2).

- 4) Push back the boots (2) near the swings (3) to expose the ends of the universal couplings (4). Using an allen key remove the grub screws (5) securing couplings to the feed roll shafts (6).

Repeat this process at the gearbox end.

- 5) The output shafts of the 'siti' gearboxes which connect to the universal couplings have a 10mm tapped hole in the face. Insert a setscrew to full thread depth of each in turn and use this to extract the output shaft approximately 50mm (see Fig 4).

Note: Whilst each output shaft is being extracted the respective universal coupling must be supported at the gearbox end to prevent it dropping.

- 6) With the universal couplings (4) free at the gearbox end slide the P.V.C. boot (2) off each shaft. Ease the universal coupling of the feed roller shafts taking care not to separate the two halves of each coupling.
- 7) Isolate air supply and then disconnect, air pipes from cylinders (7).
- 8) Unscrew the four capscrews holding the swing bracket (8) and remove, complete with swings, shafts etc. to a bench.
- 9) There is no need to separate the individual swings from the swing bracket unless to renew the bronze bushes (9).

If this is the case remove stop bar (10) by unscrewing the two setscrews securing it. This allows access to the grub screw securing the pivot shaft (11). Unscrew and remove this. Remove pivot pins (12) between air cylinders and swings (3) taking care to support and lower the cylinders to bench level.

With the cylinder pivots removed the pivot shaft (11) may now be driven out again taking care not to allow swing assemblies to fall.

The bushes (9) should be pressed out and then the bores cleaned and deburred before fitting new bushes.

When re-assembling, the right hand swing (when viewed from the rear) should have its cranked arm at the rear part of the pivot shaft (11).

To Dismantle a Feed Roll Swing

- 10) Remove key (13) and internal and external circlips (14 and 15).
- 11) Unscrew the three M3 capscrews (16) and remove them and the dust cap (17).
- 12) The feed roll shaft may now be extracted from the front of the swing.

Note: It may be necessary to tap the feed roll shaft from the rear using a soft faced mallet to break the bond between bearing and shaft.

- 13) Using a suitable driver tap the needle bearing (18) out of the front of the swing. By doing this it also removes the seal (19).

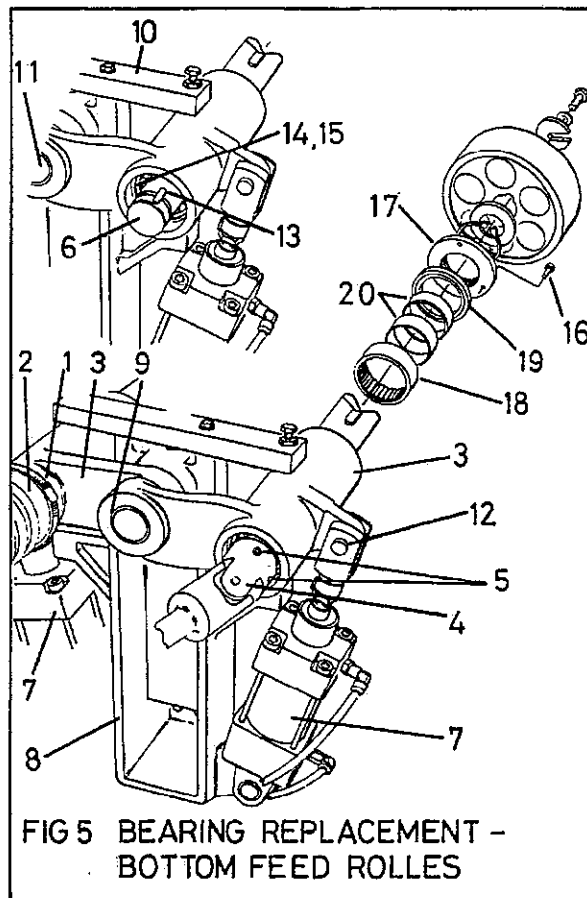

FIG 5 BEARING REPLACEMENT - BOTTOM FEED ROLLES

- 14) Using a suitable driver tap the roller bearing out of the rear of the swing (1) taking care not to damage the bores.
- 15) The 'inner rings' (20) are hardened and should not normally need changing.
- b) Ensure bearings 'butt up' to housing shoulders.
- c) Do not re-use seal (16) always replace with new. The open face of the seal should face the dust cap.

Preparation Prior To Re-assembly

Ensure all bores and shafts are clean and free from burrs. The rear roller bearing is 'sealed for life' and does not need charging with grease.

Before fitting the new needle roller bearing (18) the protective lubricant must be meticulously removed with petroleum spirit, triethanolamine or other volatile solvent.

In order to prevent the moving parts from being damaged by drying out due to over cleaning, add a small amount of the bearing lubricant to the cleaning agent at the second bath. The film of grease which remains after the solvent has evaporated will provide protection for the bearing until charged with lubricant.

The new needle bearing should be charged with 'Kluber' lubricant, type 'Isoflex' NBU 15. It is important that the correct amount of grease is applied, preferably using the formula:-

$$G \text{ (weight in grams)} = d \times B \times 0.01$$

d= Bore of bearing in mm

B= Width in mm

This is approximately sufficient to fill one third of the bearing volume.

To Assemble a Feed Roll Swing

- 16) Assembly is the reversal of the dismantling procedure although a few points should be noted:-
 - a) When fitting new bearings use 'Loctite 641' on the outer cage (fixture time 5 sec, full cure 3-6 hours).



ILLUSTRATED PARTS LIST

CONTENTS

1. **BOTTOM INFEED ROLLERS**
2. **TOP INFEED ROLLERS**
3. **PNEUMATIC 'SKID' TYPE SIDE PRESSURE**
4. **SIDE ROLLER PRESSURE**
5. **'SKID' TYPE SIDE PRESSURE - SPRING OPERATED**

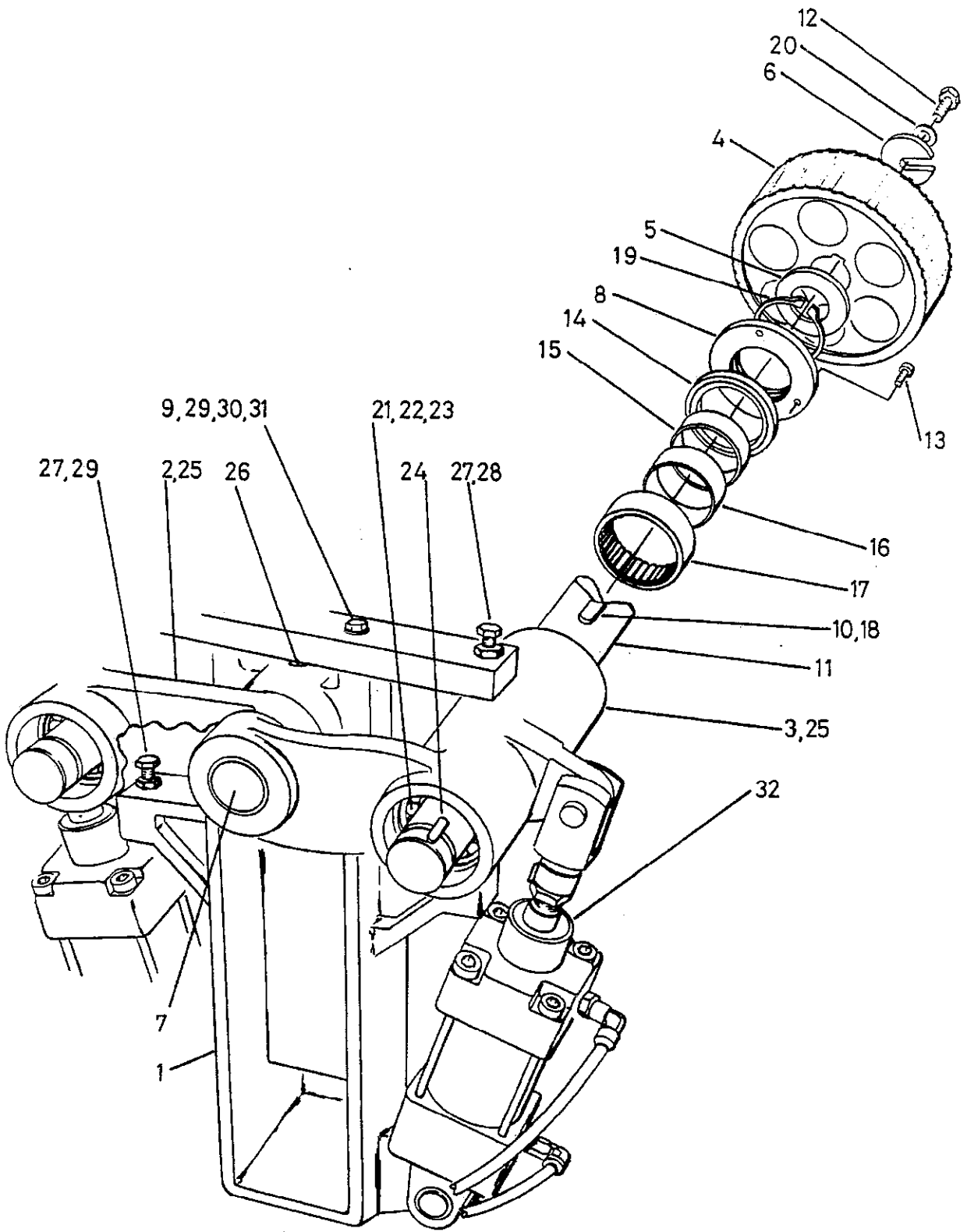

FIG 1 BOTTOM INFEED ROLLERS



1. BOTTOM INFEEED ROLLERS

Ref No.	Description	No Off.
1.	Swing bracket	1
2	Feed roll swing - left hand	1
3.	Feed roll swing- right hand	1
4.	Feed rolls - chromed	8
5.	Spacing collar	2
6.	'C' washer	2
7.	Pivot shaft for swing	1
8.	Dust cap	2
9	Stop bar	1
10.	Key 10mm x 8mm x 170mm long	2
11.	Feed roll shaft	2
12.	Hexagon head setscrew M12 x 25mm long	2
13.	Hexagon socket capscrew M3 x 8mm long	6
14.	Seal 'INA' G45 x 55 x 4	2
15.	Inner race 'INA' IR 40 x 45 x 17	2
16.;	Inner race 'INA' IR 40 x 45 x 20	2
17.	Needle bearing 'INA' NK45/20	2
18.	Hexagon socket counter sunk screw M4 x 16mm long	4
19.	External circlip 40mm dia.	2
20.	Plain washer M12	2
21.	Bearing 'SKF' 6006-2RS	2
22.	Internal circlip 55mm dia.	2
23.	External circlip 30mm dia.	2
24.	Key 8mm x 7mm x 36mm	2
25.	Bronze bush 35mm O/D x 30mm I/D x 25mm wide	4
26.	Hexagon socket grubscrew M10 x 16mm long	1
27.	Locknut M10	4
28.	Hexagon head setscrew M10 x 50mm long	2
29	Hexagon head setscrew M10 x 35mm long	4
30.	Plain washer M10	2
31.	Spring washer M10	2
32.	Cylinder 'Parker' 5E63 B30/5 RC63 (complete with pivot pins, clevis and clips)	2

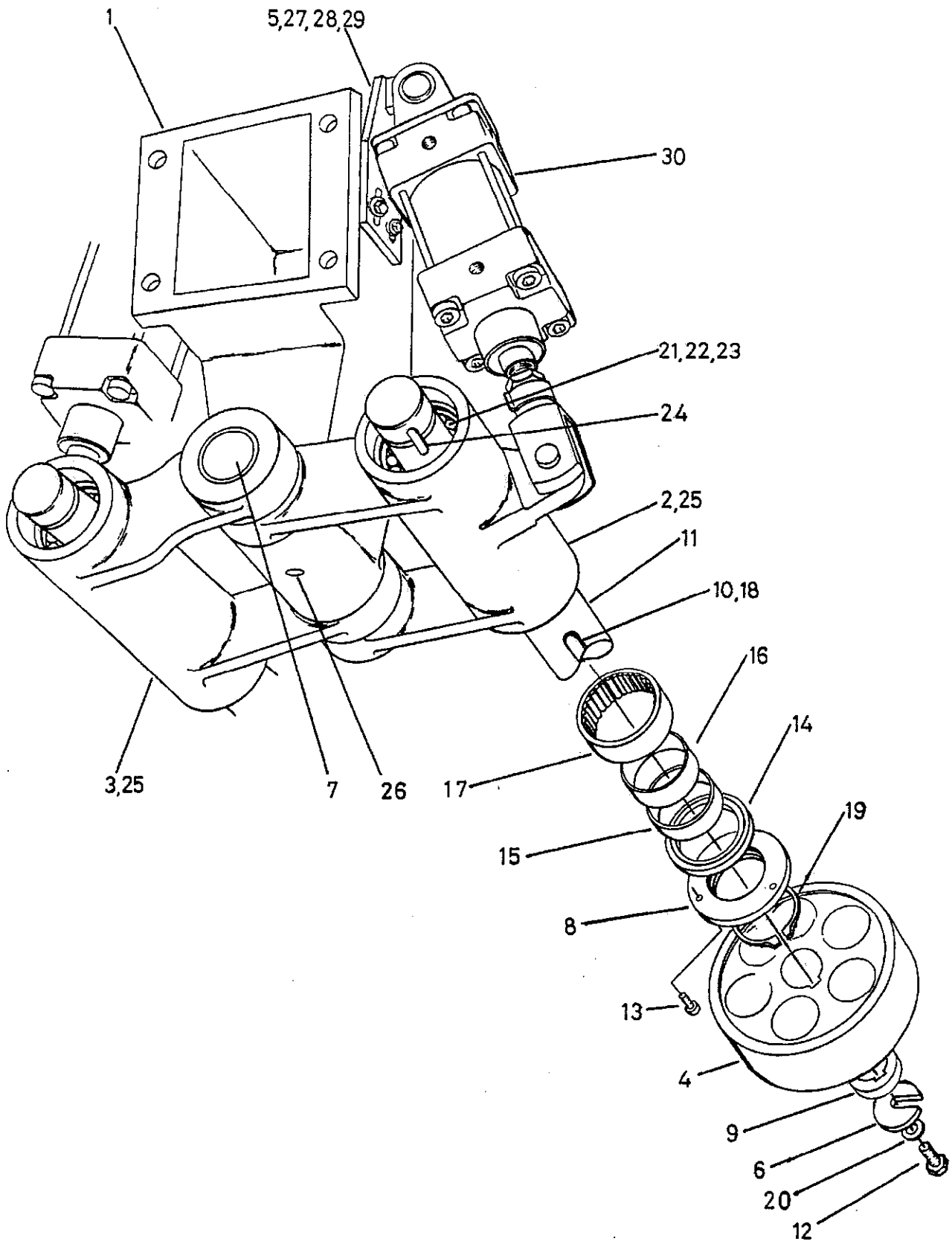

FIG 2 TOP INFEED ROLLERS



2. TOP INFEED ROLLERS

Ref No.	Description	No Off.
1.	Swing bracket	1
2	Feed roll swing - left hand	1
3.	Feed roll swing- right hand	1
4.	Feed rolls - polyurethane	8
5.	Mounting for top feedroll cylinders	2
6.	'C' washer	2
7.	Pivot shaft for swing	1
8.	Dust cap	2
9	Spacers for feed rolls (specify width)	
10.	Key 10mm x 8mm x 170mm long	2
11.	Feed roll shaft	2
12.	Hexagon head setscrew M12 x 25mm long	2
13.	Hexagon socket capscrew M3 x 8mm long	6
14.	Seal 'INA' G45 x 55 x 4	2
15.	Inner race 'INA' IR 40 x 45 x 17	2
16.;	Inner race 'INA' IR 40 x 45 x 20	2
17.	Needle bearing 'INA' NK45/20	2
18.	Hexagon socket counter sunk screw M4 x 16mm long	4
19.	External circlip 40mm dia.	2
20.	Plain washer M12	2
21.	Bearing 'SKF' 6006-2RS	2
22.	Internal circlip 55mm dia.	2
23.	External circlip 30mm dia.	2
24.	Key 8mm x 7mm x 36mm long	2
25.	Bronze bush 35mm O/D x 30mm I/D x 25mm wide	4
26.	Hexagon socket grub screw M10 x 16mm long	1
27.	Hexagon head setscrew M10 x 25mm long	4
28.	Plain washer M10	4
29.	Hexagon socket grub screw M6 x 6mm long	2
30.	Cylinder 'Parker' 5E63 B30/5 RC63 (complete with pivot pins, clevis and clips)	2
31.	Feed roll hub	8

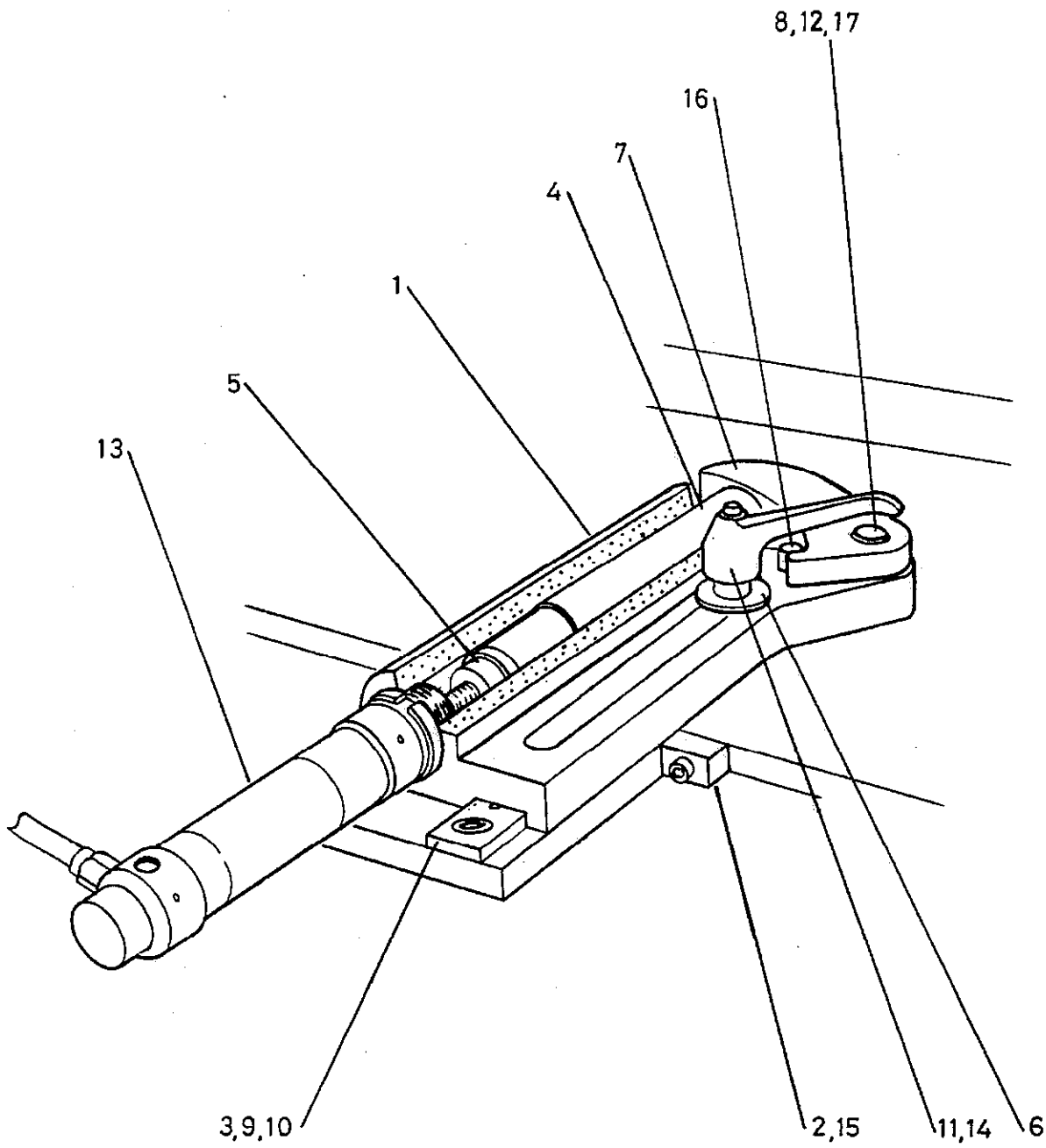

FIG 3 PNEUMATIC 'SKID' TYPE SIDE PRESSURE



3. PNEUMATIC 'SKID' TYPE SIDE PRESSURE

Ref No.	Description	No Off.
1.	Bracket	1
2.	Support for bracket	1
3.	Tenon for support	1
4.	Plunger	1
5.	Sleeve	1
6.	Clamping washer	1
7.	Skid link	1
8.	Pivot link	1
9.	Tension pin dia. 8mm x 24mm long	2
10.	Hexagon socket counter sunk setscrew M8 x 16mm long	2
11.	Locking handle M12 (female)	1
12.	Bronze bush O/D 25mm x I/D 20mm x 15mm	1
13.	'Festo' single acting cylinder ref ESW-32-50P	1
14.	Stud M12 x 50mm long	1
15.	Hexagon socket capscrew M10 x 30mm long	2
16.	Plain dowel dia. 12mm x 40mm long	1
17.	Taper pin	1

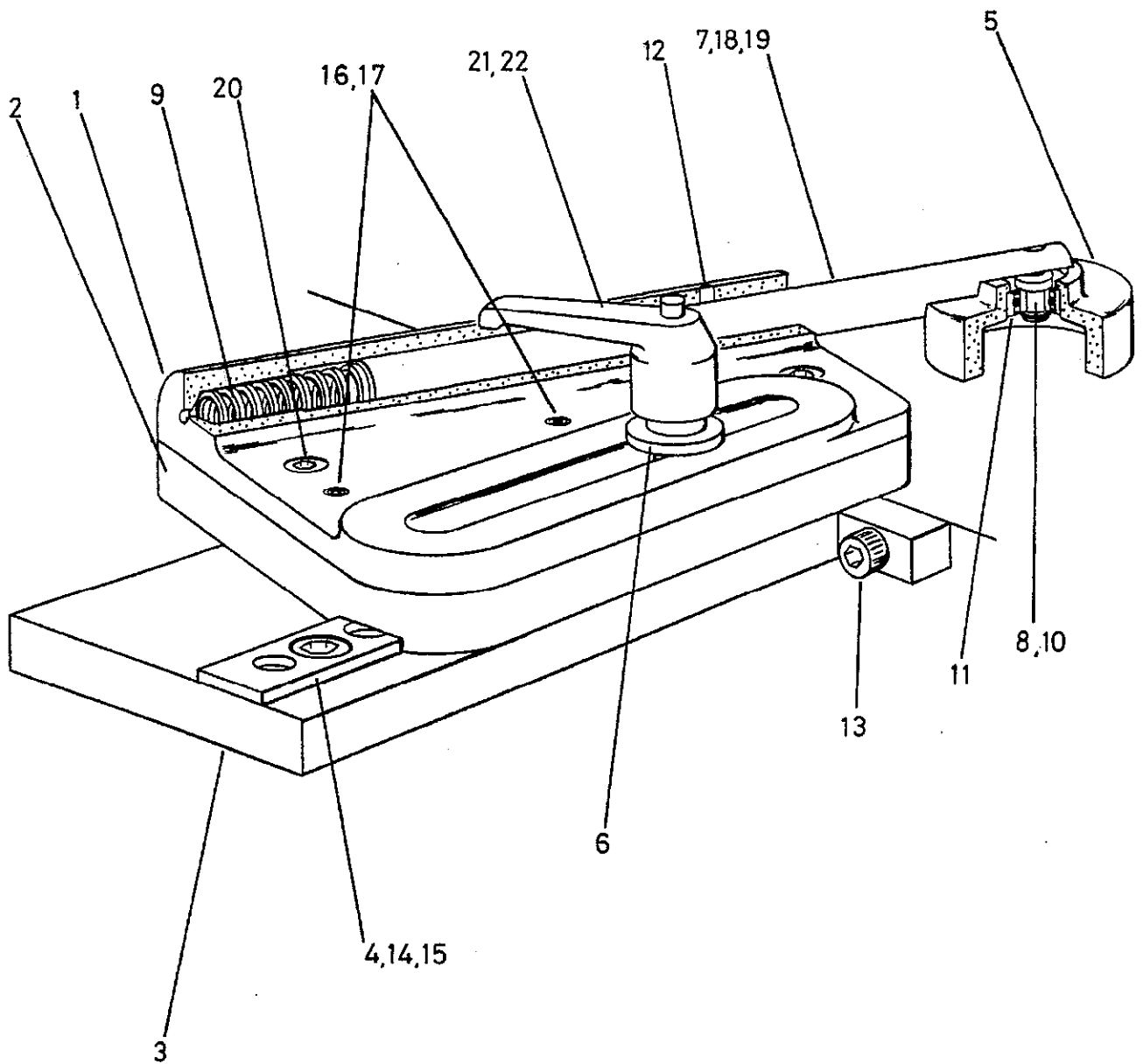

FIG 4 SIDE ROLLER PRESSURE

**4. SIDE ROLLER PRESSURE**

Ref No.	Description	No Off.
1.	Side pressure bracket	1
2.	Block for pressure bracket	1
3.	Support for pressure bracket	1
4.	Check strip	1
5.	Roller	1
6.	Clamping washer	1
7.	Sliding shaft	1
8.	Roller pin	1
9.	Compression spring 70mm free length,12 coils,O/D 23.35mm , I/D 17.46mm , 2.9mm wire thickness	1
10.	External circlip 20mm	1
11.	Bearing 'SKF' 6004-2RS	1
12.	Black nylon plug	1
13.	Hexagon socket capscrew M10 x 30mm long	2
14.	Hexagon socket counter sunk screw M8 x 20mm long	2
15.	Tension pin dia. 8mm x 20mm long	2
16.	Tension pin dia. 8mm x 24mm long	2
17.	Tension pin dia. 4mm x 26mm long	2
18.	Tension pin dia. 8mm x 30mm long	1
19.	Tension pin dia. 5mm x 30mm long	1
20.	Hexagon socket counter sunk screw M6 x 25mm long	2
21.	Locking handle M12 (female)	1
22.	Stud M12 x 65mm long	1

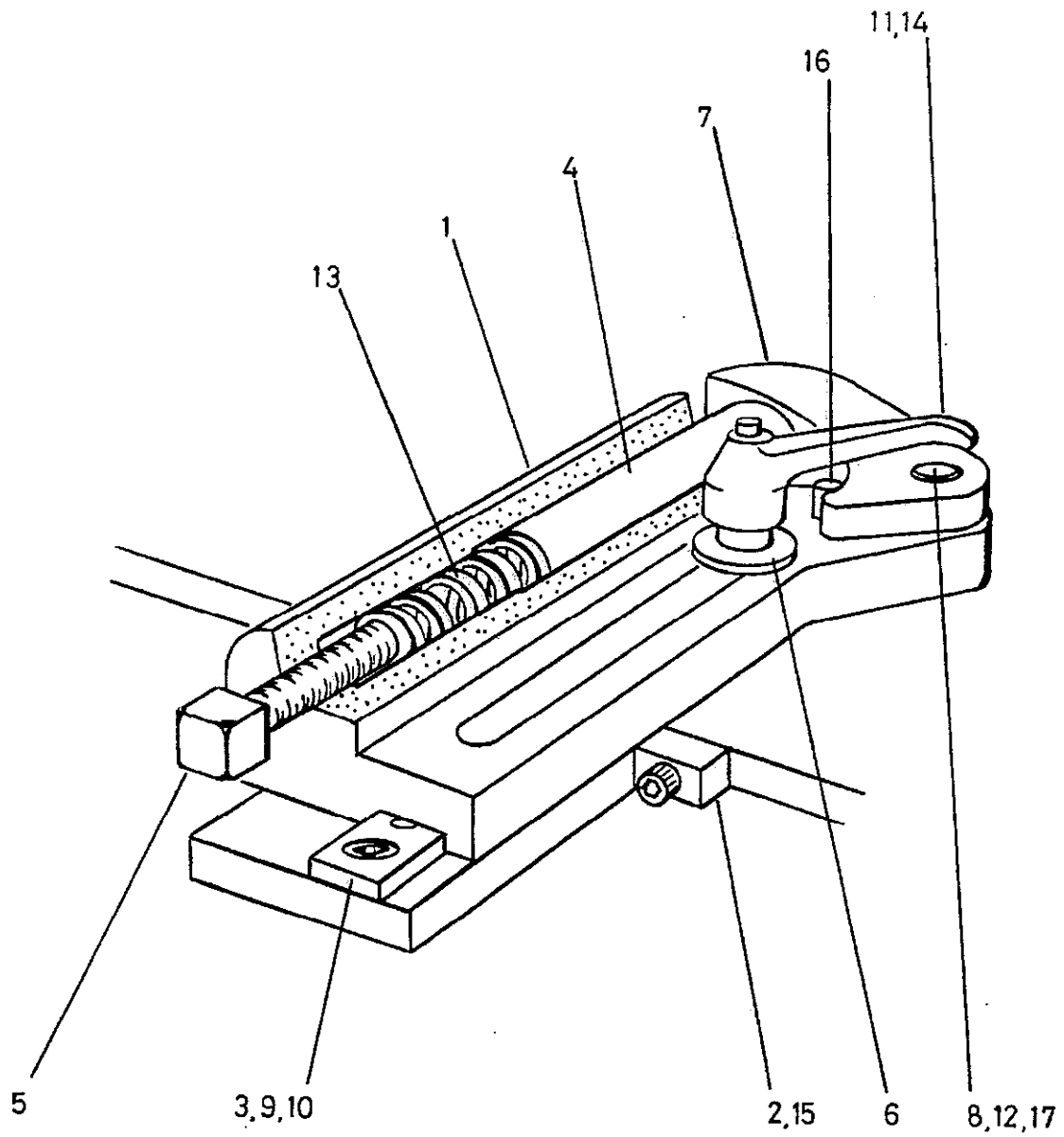

FIG 5 'SKID' TYPE SIDE PRESSURE - SPRING OPERATED



5. 'SKID' TYPE SIDE PRESSURE - SPRING OPERATED

Ref No.	Description	No Off.
1.	Bracket	1
2.	Support for bracket	1
3.	Tenon for support	1
4.	Plunger	1
5.	Tension screw	1
6.	Clamping washer	1
7.	Skid link	1
8.	Pivot link	1
9.	Tension pin dia. 8mm x 24mm long	2
10.	Hexagon socket counter sunk setscrew M8 x 16mm long	2
11.	Locking handle M12 (female)	1
12.	Bronze bush O/D 25mm x I/D 20mm x 15mm	1
13.	Compression spring 187.3mm free length, O/D 24.6 mm, I/D 17.3 mm, 31 coils	1
14.	Stud M12 x 50mm long	1
15.	Hexagon socket capscrew M10 x 30mm long	2
16.	Plain dowel dia. 12mm x 40mm long	1
17.	Taper pin	1

SECTION 6 BOTTOM HEAD MODULE

General (Fig 1)

This unit comprises of a cutterblock spindle, belt driven from a horizontally mounted motor at the rear of the module.

Timber passage over the module is via shaft mounted top through feed rollers leading and trailing the cutterblock and an opposed top roller/bottom roller combination at the outfeed end of the unit. All rollers are driven at the back of the module through 'Siti' gearboxes (see chapter - **Gearboxes and Drive Shafts**).

Due to modern machining techniques movement in the horizontal (lateral) plane is seldom if ever required. When fitted movement in this direction is factory set to give approximately 12mm adjustment backwards from the datum face of the fence when it is set at zero.

If it should be necessary to obtain further lateral movement when at the maximum rearward position, it may be obtained in the following manner:-

Isolate power supply at mains or by using master stop.

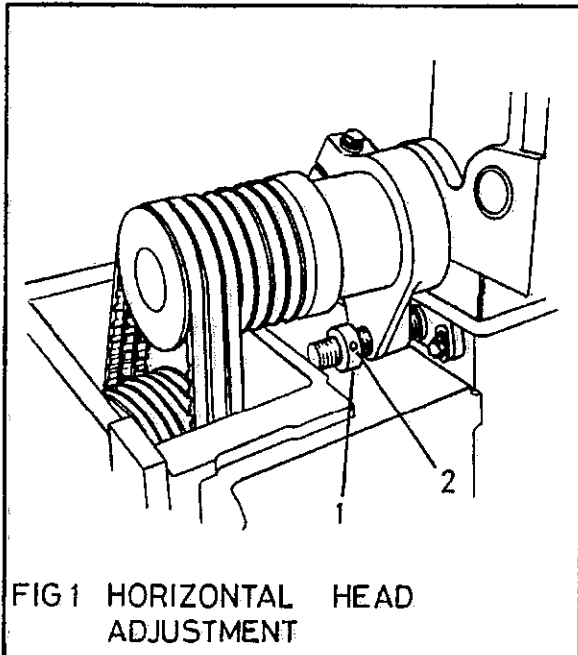

FIG 1 HORIZONTAL HEAD ADJUSTMENT

Remove the pulley guard and release the belt tension (refer to Maintenance - **Vee Belt Drive Tensioning**). Move the belts onto the next vacant pulley groove to bring them back into line and then re-tension the belts.

Locking collars prevent the spindle movement exceeding the original factory set boundaries and therefore if the belts are repositioned, then the rear stop (1) must also be reset.

This may be done by slackening off the grub screw (2), moving the collar back a further 12mm and then retightening the grub screw (2).

Bottom Head Vertical and Horizontal Adjustment (Fig 2, Fig 3)

Spindle adjustment where provided may be adjusted within its limits in both planes from the front of the module.

To Check Cutterblock Height

- 1) Isolate power supply at mains or by using master stop.
- 2) Remove/raise guards to allow clear access to bedplates and cutterblock.
- 3) Ensuring bedplates are clean place a straight edge (1) on the outfeed table of the module projecting over the bottom horizontal cutterblock.

If set correct the blades should just touch the underside of the straight edge. Adjust cutterblock height if necessary.

Vertical Adjustment

- 4) Isolate power supply at mains or at master stop if not already isolated.

- 5) Release outboard housing locking handles (2).

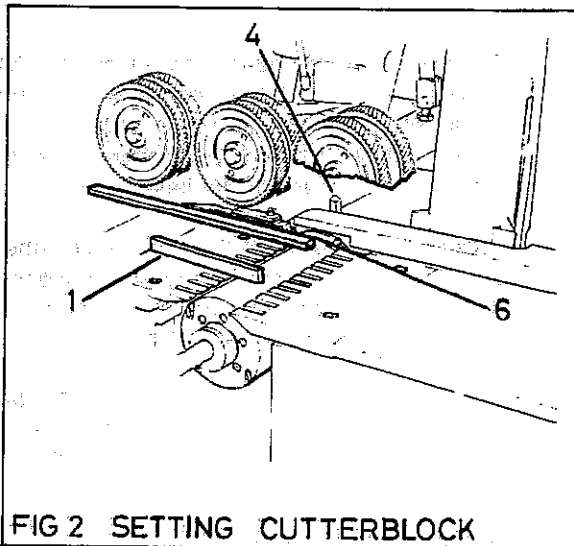

FIG 2 SETTING CUTTERBLOCK

- 6) Using supplied winding handle rotate adjusting screw (3) clockwise to raise the spindle or anti-clockwise to lower.
- 7) When the correct height has been achieved tighten locking handles (2) and engage power if no further adjustments are necessary.

Horizontal Adjustments (if fitted).

- 8) Ensure power is isolated at mains or at master stop. Remove conical outboard bearing cover.
- 9) Before making any lateral adjustments, the hexagon spindle barrel lock (4) situated behind the fence must be released and the outboard bearing (9) depressurised by turning the pressure release valve (5) one quarter turn anti-clockwise using a 3mm Allen key.
- 10) Position cutterblock as required using adjusting screw (8). If edge reference is fitted a straight edge (6) should be placed along the main fixed fence to

set the blades of the edge reference cutter approximately 0.75mm behind datum fence line.

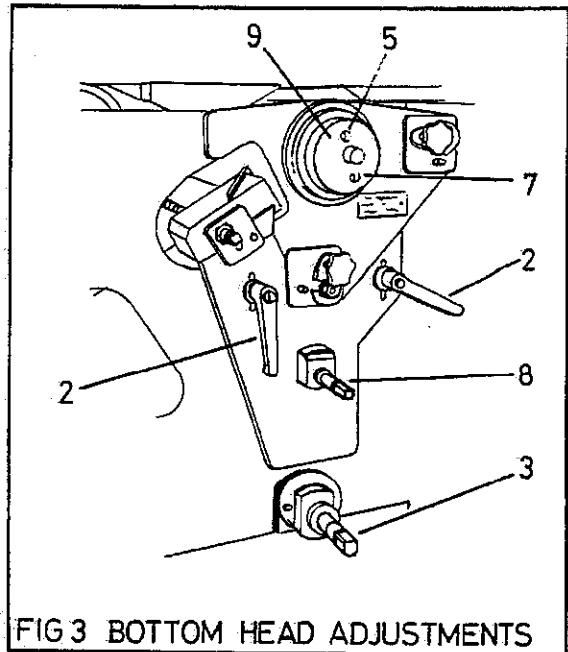

FIG 3 BOTTOM HEAD ADJUSTMENTS

- 11) Refasten spindle barrel lock (4) and close pressure release valve (5). Pressurise bearing to 300 bar by application of hydraulic pressure to the nipple (7) in the recess on the face of the outboard (9). Replace outboard cover and engage power if no further adjustments are required.

Adjustment to Top and Bottom Through Feed Rollers

For information relating to adjustment, maintenance and parts refer to chapter - **Driven Bed and Top Through Feed Rollers.**

Adjustment of Side Pressure after Bottom Head (Fig 4)

The 'skid' type side pressure is only fitted when the bottom module is followed by a Top or Top/Bottom Head Module. The side pressure mounting, fixed to the bedplate, carries a tenon which guides the pressure tangential to the timber.

- 1) Release locking handle (1) and adjust the side pressure to suit timber width.
- 2) When set re-tighten handle

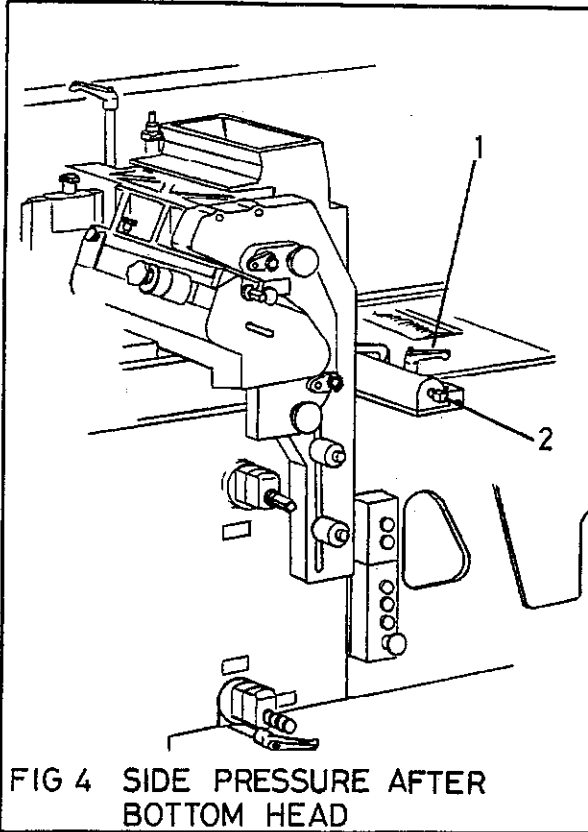

FIG 4 SIDE PRESSURE AFTER BOTTOM HEAD

- 3) Turning screw (2) in a clockwise direction increases the spring tension and stiffens the 'skid' movement.

Turning the screw in an anti-clockwise direction has an opposite effect.

MOUNTING THE CUTTERBLOCKS

General

The XJS machine can be fitted with plain bore or Hydrogrip (hydraulic pressure) cutterblocks. Hydrogrip cutterblocks are used to provide an improved surface finish and allow higher feed speeds to be used. The method of fitting the two types differs.

When changing cutterblock, be aware that the spindles for plain bore blocks have right or left hand threads, dependent on spindle location, and tighten accordingly.

The Hydrogrip blocks are not screw fitting and require to be pressurised in position on the spindle. To protect the Hydrogrip cutterblock and the machine spindle in the event of hydraulic failure, it is necessary for safety drive collars to be used.

The consequence of not using the safety drive collars will result in the cutterblock seizing on the machine spindle in the event of either; the operator neglecting to pressurise the cutterblock and then running the spindle, or the Hydrogrip cutterblock sleeve losing pressure.

If a seizure occurs, the spindle and cutterblock must be returned to Wadkin for repair. An appropriate charge will be made for this service.

Two types of safety collar are used. These are a threaded safety collar; for use when full length tooling is in use on the machine spindle. A plain safety collar; for use when short length tooling is used on the machine spindle.

Outboard bearings are fitted to the horizontal spindles to give greater rigidity to the cutterblock; these support each spindle at its outer position.

The outboard bearing support bracket on the bottom heads is attached and locked to the support plate manually.

The outboard bearings must be depressurised before removal or making lateral (horizontal) adjustments to the bottom heads.

To Change Cutterblock (Fig 1, Fig 2, Fig 3)

The method of changing cutterblocks depends on the type fitted and it will be first necessary to remove any outboard bearing, locking collar, spindle nut, and spacers fitted, as applicable. Isolate machine from power source.

- 1) Remove the conical shaped outboard bearing cover.
- 2) Depressurise the outboard bearing (8) by turning the pressure release valve (4) one quarter of a turn using a 3mm Allen Key.
- 3) Slacken off the two 12mm collar nuts (1), swing captive 'C' washers (2) clear and remove outboard bearing housing (3).

Note: This housing is spigoted and must be pulled off parallel to the spindle.

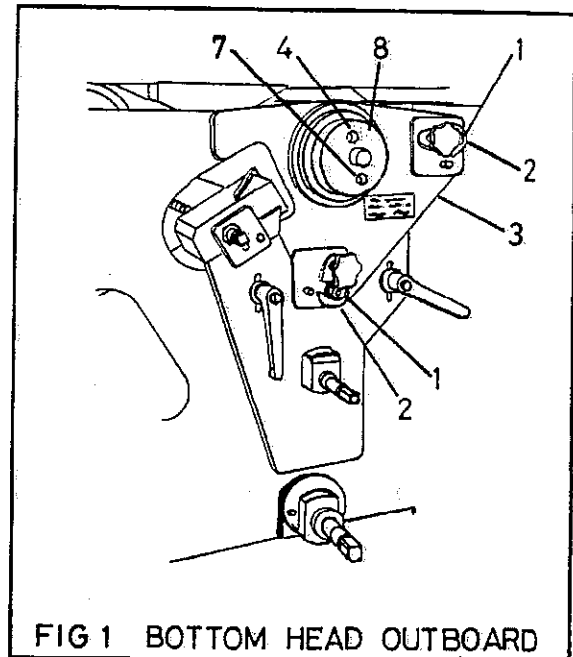



- 4) Remove cutterblock off spindle.

Caution When handling cutterblocks care should be taken to avoid injury on knife blades. The method of removal varies depending on the type of block.

- a) *Plain bore cutterblock.*

Unscrew the cutterblock nut from the spindle with the spanner/s provided. Can be right or left-hand thread (see **General**).

Place the spanner/s on the hexagon of the spindle and the two flat faces of the cutterblock locknut, or;

Hold the spanner (top) securing the spindle firmly in position and unscrew the cutterblock locknut from the spindle with the bottom spanner.

Remove cutterblock.

Note: **DO NOT** use any form of percussion tool or damage to spindle bearings can result. **DO NOT** use a box or extension spanner.

- b) *Hydrogrip cutterblock with Plain Collar*

Untightening the capscrew in the collar using an Allen key, releases the collars grip on the spindle allowing it to be slid off.

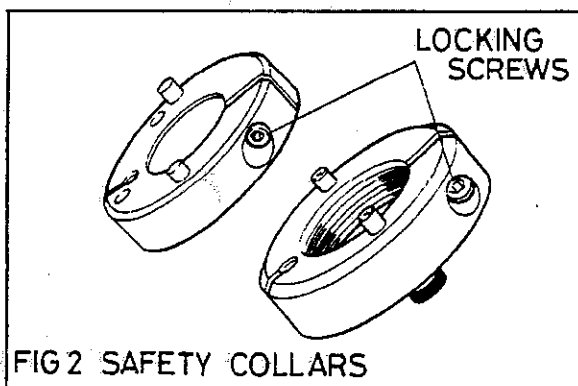

Note: On reassembly ensure the collar is fitted with its locating pins facing cutterblock.

Depressurise the hydrogrip cutterblock by turning the pressure release screw (5), located in a recess on the barrel of the cutterblock one quarter turn to release, using a 3mm A/F hexagon key.

Slide the cutterblock from the spindle.

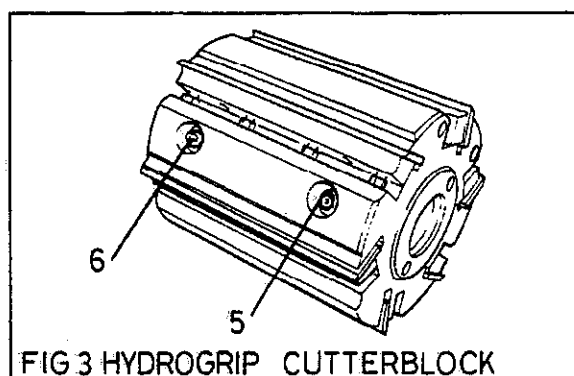

Always leave the pressure release screw (5) undone when the cutterblock is not in use to avoid distortion to the cutterblock due to the variation in room temperatures.

- c) *Hydrogrip cutterblock with threaded collar.*

Release the capscrew in the safety collar using an Allen Key. Unscrew the two knurled headed pins until the collar is free to unscrew.

Note: On assembly this collar must be screwed finger tight against the pressurised block and then if needed unscrewed until the pins line up with corresponding cutterblock holes.

Depressurise the hydrogrip cutterblock by turning the pressure release screw



(5), located in a recess on the barrel of the cutterblock one quarter turn to release, using a 3mm A/F hexagon key.

Slide the cutterblock from the spindle.

Always leave the pressure release screw (5) undone when the cutterblock is not in use to avoid distortion to the cutterblock due to the variation in room temperatures.

- 5) Before replacing cutterblock ensure spindle, spindle shoulder, shoulders of cutterblock and bores are all clean.
- 6) Carefully place the cutterblock on the spindle. On the Hydrogrip blocks tighten pressure release screw (5), and pressurise the cutterblock by applying hydraulic pressure to the pressure nipple (6) located in a recess located on the barrel of the block (see fig 3).
- 7) Fit safety collars and/or spacers as applicable. On the plain bore cutterblocks, tighten the block to the spindle with the spanner/s provided.
- 8) Replace bearing housing (3) and retighten captive 'C' washer (2) and collar nuts (1). Tighten pressure release valve (4) and pressurise bearing to 300 bar (4350 p.s.i.) by application of hydraulic pressure to the nipple (1) in the recess on the face of the bearing. See NB.
- 9) Rotate spindle slowly by hand to check knives are clear off chipbreaker etc. Replace cover, engage power and start head for a short period of time to ensure smooth rotation without vibration.

NB. before pressurising the outboard bearing, set the bearing in the mid position of its axial adjustment, to allow for final setting of the cutter block.

MAINTENANCE

Routine Maintenance

Caution: Before proceeding with any maintenance ensure power is off at mains or at master stop.

Weekly

It is recommended that the machine be cleaned thoroughly once a week, especially when working on hardwood or highly resinous material, to prevent choking of ventilator airways and build up of deposits on working parts.

Clean all spindles regularly and remove all remains of resin and grease. Do the same with the cutterblock collars and machine tables.

Check that all machine parts slide, or rotate freely. Lightly lubricate as directed, do not over-lubricate.

If cleaning with compressed air, take care not to direct the jet onto the spindle bearing housings, moving shafts, etc., and avoid forcing dust and debris into bearings and housings.

Centralised lubrication points at the front of the machine allows for oiling of the bottom head slideway as part of an overall oiling operation.

The slideways should be oiled at weekly intervals and then adjusted through its extrem positions to ensure even distribution of oil and prevent dense sawdust particle build up. 'Wadkin' grade '4' oil should be used (see **Approved lubricants**).

Three Monthly (Fig 1)

Electric drive motors have 'sealed for life' bearings and are maintenance free. However the fan cowl should be removed at intervals and the fan checked for damage, excessive end float, signs of overheating, etc. If the cowl itself is damaged it should be replaced.

Remove drive belt cover at rear of module and clean the spindle barrel lateral adjustment

screw (1). Grease traverse screw using Wadkin L6 grease.

With the cover off, the spindle drive belts and tension can be checked. The belts (2) should be capable of being depressed approximately 1 1/2 to 2cm per metre of span, by application of average thumb pressure of 2.2 - 3.2 kgf (5-7 lbf).

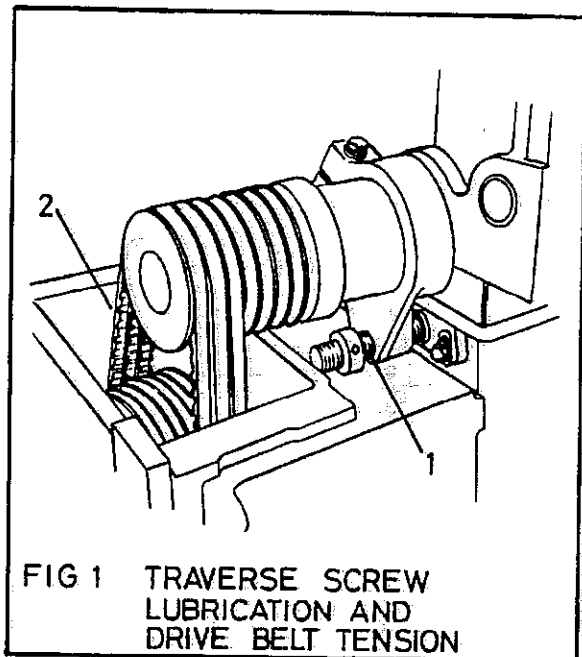

Retension if required and refit cover.

Vee Belt Drive Tensioning (Fig 2)

It is important that drive belts are correctly set as insufficient tension causes slipping and premature belt wear. The method of adjustment is as follows.

- 1) Isolate power at master stop or mains.
- 2) Remove cover to expose spindle pulley and belts (Fig 1).

- 3) Slacken off motor mounting plate bolts (1).

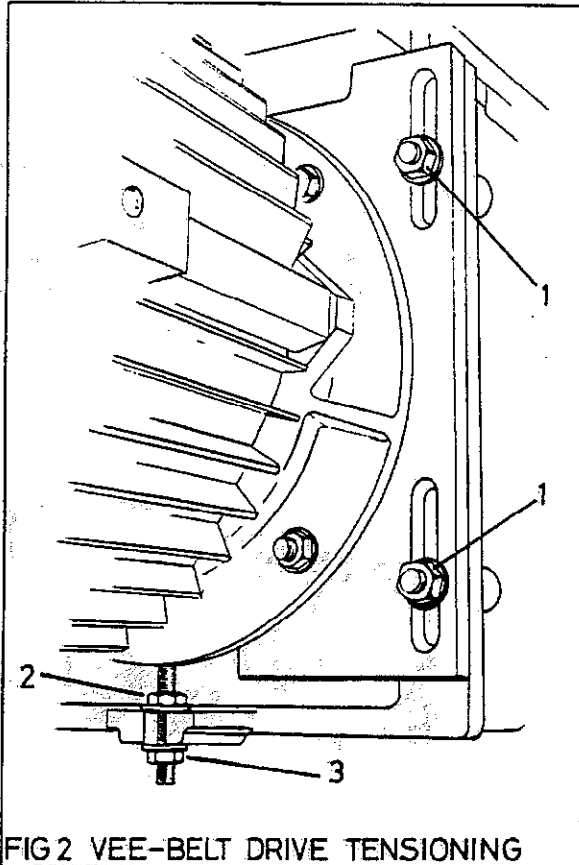

- 4) Tension belt by slackening the top locknut (2) and turning the bottom locknut (3) in an anti-clockwise direction.
- 5) When tensioned lock up both nuts (2 and 3) and motor mounting bolts (1). Refit cover and engage power.

There may be occasions where the tensioning arrangement does not follow that described. However, all belt drive adjustment follows the same general principle: This involves moving the drive pulley centres or motor platform, thus taking up any slack in the belt drive. The method used will normally be self evident. Always retighten any securing features fitted.

If one or more of the vee-belts becomes faulty it will usually be necessary to replace as a

complete set. (See Replacing Drive Belts.) It is impossible to obtain a correctly tensioned drive, with all belts taking an equal share of the load, by mixing old and new, or different belts.

Replacing Drive Belts (Fig 2)

Drive belts must be replaced as a set to obtain correct drive performance.

- 1) Isolate power at master stop or mains.
- 2) Remove cover.
- 3) Relieve tension on belts by reducing drive centres i.e. slacken off the four motor mounting bolts (1), the locknut (3) and raise the motor by rotating nut (2) in a clockwise direction.
- 4) Remove old drive belts and fit a new set of belts of the same size, type and reference (see **Motor and Drive Belt Data**).
- 5) Retension the new belt set (see **Vee Belt Tensioning**).

Note: It may at times be necessary to remove a drive pulley. The fitted motor shaft pulleys are fitted with Taper-Lock bushes (see fig 4), cutterblock spindles are fitted with parallel keys. (See **Remove and Refit Drive Pulleys**).

Remove and Refit of Drive Pulleys (Fig 3)

To remove a Taper-Lock bush pulley:

- 1) Slacken off all screws (1) several turns using a hexagonal key. Remove one or two screws according to number of jacking holes (2).
- 2) Insert screws in jacking holes after oiling thread and point of grub screws, or thread and head of cap screws, as applicable.

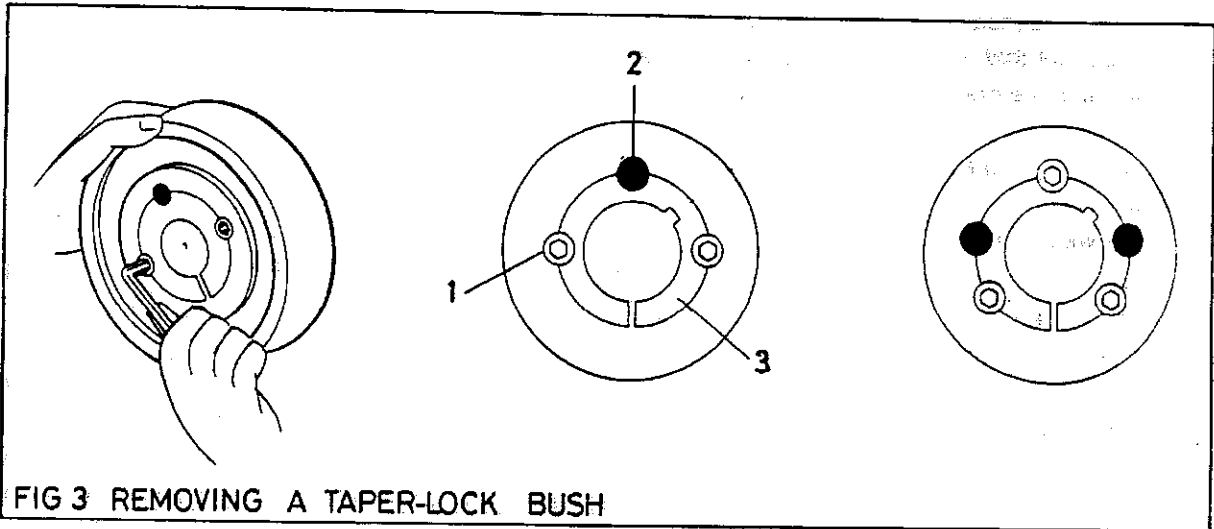

FIG 3 REMOVING A TAPER-LOCK BUSH

- 3) Tighten screws (1) alternatively until bush (3) is loosened in Pulley hub and assembly is free on shaft.
- 4) Remove pulley assembly from shaft.

To refit a Taper-Lock bush pulley:

- 1) Ensure that mating taper surfaces are completely clean and free from oil or dirt. Insert bush in hub and line up screw holes.
- 2) Oil thread and point of grub screws, or thread and head of cap screws. Place screws (1) loosely in threaded holes in hub of pulley.
- 3) Clean shaft, fit hub and bush to the shaft as a unit. Locate in position. On fitting; the bush will nip the shaft first, then hub will be drawn onto bush.

Note: It is necessary to axially align drive and driven pulleys.

- 4) Using a hexagon key, alternatively tighten screws (1), until all screws are pulled up securely. Use a short length of pipe on key to increase leverage.

- 5) After the drive has been running under load for a short time, stop and check tightness of screws. Tighten if needed.
- 6) Fill empty screw holes with grease to exclude dirt.

Changing Outboard Bearing (Fig 4)

Work must be carried out in a clean and dry environment. Failure to do so could result in premature bearing failure.

Preparation Prior to Fitting Bearings

Before fitting a new bearing, the protection lubricant must be meticulously removed with petroleum spirit, triethanolamine, or other volatile solvent.

In order to prevent the moving parts from being damaged by drying out due to over cleaning, add a small amount of the bearing lubricant to the cleaning agent at the second bath. The film of grease which remains after the solvent has evaporated will provide protection for the bearing until charged with lubricant.

The new bearings should be charged with 'Kluber' lubricant, type 'Isoflex' NBU 15. It is important that the correct amount of grease is applied, preferably using the formula:

$$G \text{ (weight in grams)} = d \times B \times 0.01$$

d = bore of bearing in mm

B = width in mm

This is approximately sufficient to fill one third of the bearing volume.

Changing Outboard Bearing

- 1) Isolate power at master stop or at mains.
- 2) Remove conical shaped outboard bearing cover.
- 3) Depressurise and remove outboard bearing as described previously in 'Changing Cutterblock/Saws'.

- 4) Remove bearing locknut (2), un-screw hexagon socket capscrews (10) and remove the protective ring (1), it is not necessary to remove the grease nipple (9) or the pressure release valve (8).
- 5) Remove the end cap for the outboard bearing housing (5) by removing 4-off hexagon socket capscrews (11).
- 6) Withdraw the ETP sleeve (12), the bearing spacer (3) and the spring disc (4). The bearing (6) should be withdrawn with the sleeve, unless the failure of the bearing (6) has caused it to seize in the housing (7). If the bearing is stuck in the housing remove it using a bearing puller on the bearing rings. Take care not to damage the housing (7).

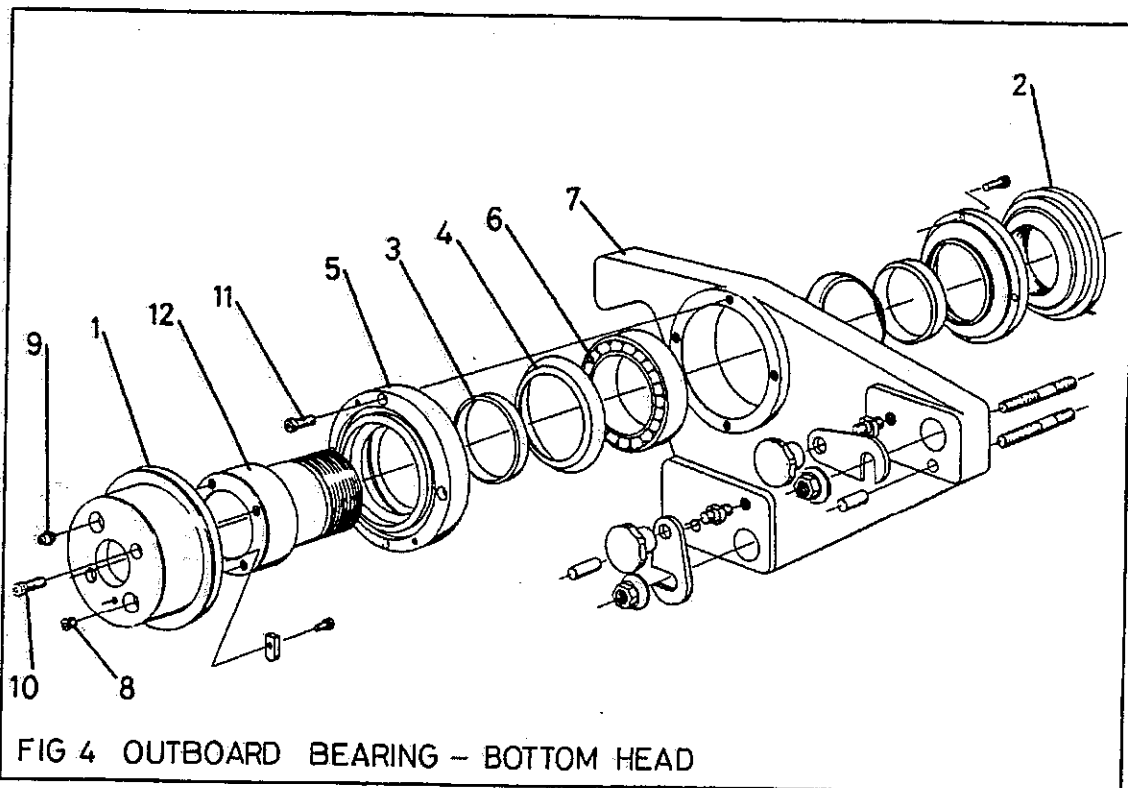

FIG 4 OUTBOARD BEARING - BOTTOM HEAD



BOTTOM HEAD MODULE

- 7) After preparation, (see *preparation prior to fitting bearing*) fit new bearing (6) to ETP sleeve (12) ensuring that the bearing spacer (3) and the disc spring (4) have also been fitted. Use only sufficient pressure to fit bearings, applying pressure to the inner ring only. Ensure that bearing ring fits up to location.
- 8) Lubricate bearing (see *preparation*).
- 9) Reassemble unit by reversing stages 3),2),1) ensuring that the labrinyth seals in the outboard bearing end caps (5) are refilled with grease. Care must be taken when fitting bearing locknut (2) not to overtighten. A small amount of engineering adhesive (Loctite grade 241) should be applied to the thread of the bearing locknut (2).
- Note:** The bonding adhesive from the previous assembly may be left as a powder and must be removed before applying further adhesive.
- 10) Check that outboard assembly runs freely when turned by hand.
- 11) Re-position bearing housing, secure and re-pressurise as described in '**Changing Cutterblock Saws**'
- 12) Replace outboard cover and engage power.



ILLUSTRATED PARTS LIST

CONTENTS

1. Bottom Head Axial Adjustment
2. Bottom Head Rise and Fall Adjustment
3. Pneumatic 'Skid' Type Side Pressure
4. Spring Operated 'Skid' Type Side Pressure
5. Bottom Head Outboard Bearing

IMPORTANT: WHEN ORDERING SPARES ALWAYS QUOTE
MODEL AND MACHINE NUMBER.

BOTTOM HEAD MODULE

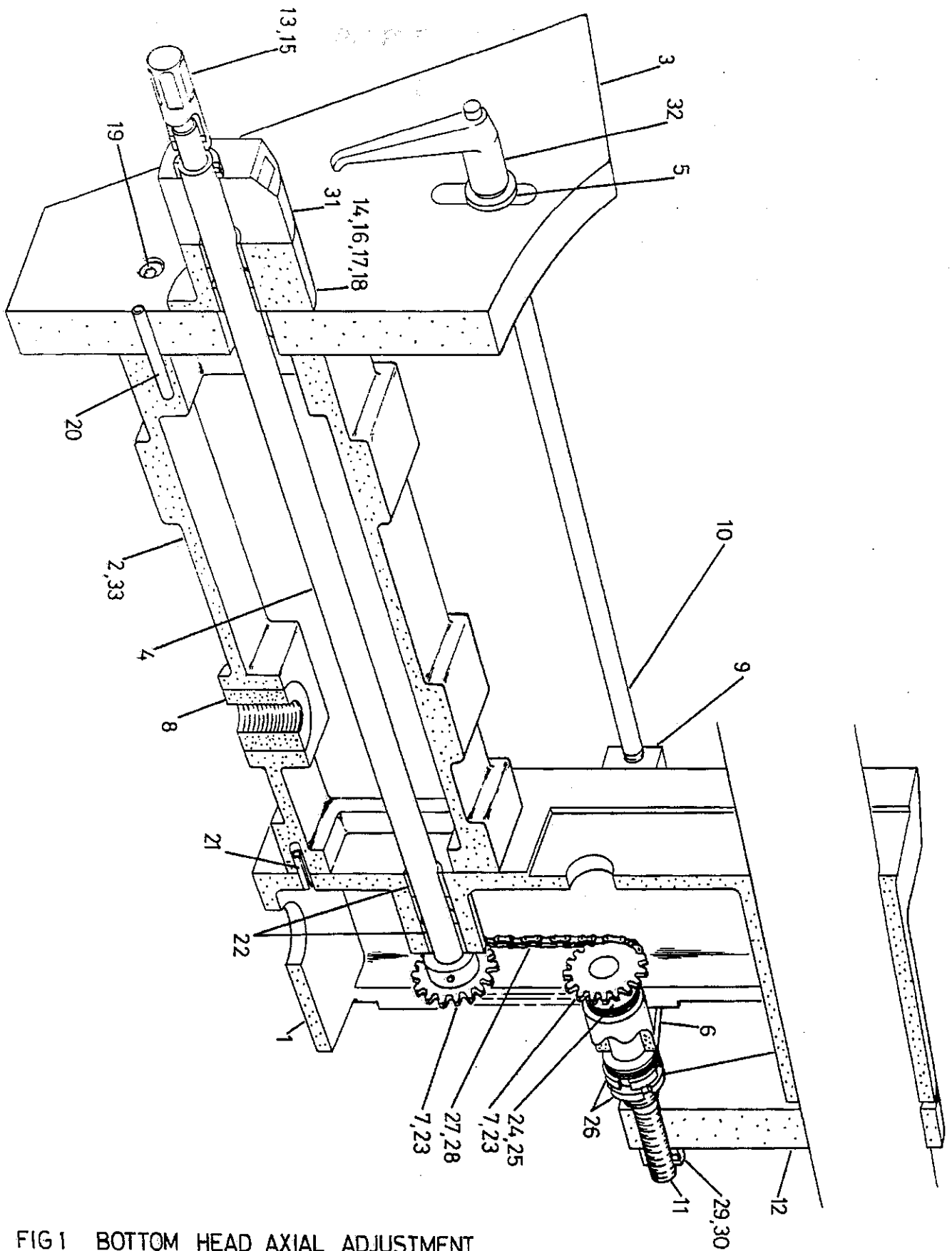

FIG 1 BOTTOM HEAD AXIAL ADJUSTMENT



BOTTOM HEAD MODULE

1. BOTTOM HEAD AXIAL ADJUSTMENT

Ref No.	Description	No Off.
1.	Bottom head vertical slide	1
2.	Stretcher for bottom head	1
3.	Front plate	1
4.	Axial adjustment shaft	1
5.	Clamping washer	2
6.	Bearing bracket	1
7.	Chain sprocket	2
8.	Nut for bottom head rise and fall	1
9.	Locking pad for slide	1
10.	Shaft for bottom head clamping	1
11.	Sprocket shaft for axial adjustment	1
12.	Barrel clamping nut for axial adjustment	1
13.	Square end shaft extension	1
14.	Bracket for axial shaft bearings	1
15.	No 1 Taper pin	1
16.	Hexagon socket cap screw M8 x 25mm long	2
17.	Plain washer M8	2
18.	Bush 25mm O/D x 20mm I/D x 15mm long	2
19.	Hexagon socket cap screw M10 x 25mm long	4
20.	Dowel 8mm diameter x 40mm long	2
21.	Tension pin 8mm diameter x 35mm long	2
22.	Bush 25mm O/D x 20mm I/D x 20mm long	2
23.	Taper pin No 4	2
24.	'INA' Thrust bearing AXK - 2542	2
25.	'INA' Thrust washer AS 2542	4
26.	Notch nut M24 x 1.5mm pitch	2
27.	Chain connecting link No 26	1
28.	'Reynold' chain 1/2" pitch x 39 pitches	1
29.	Threaded collar M20 trapezoidal	1
30.	Hexagon socket grub screw M8 x 8mm long	1
31.	'Siko' position indicator 0902E 4mm	1
32.	Locking handle M12	2
33.	Hexagon socket capscrew M10 x 30mm long (stretcher to side fastening)	4

BOTTOM HEAD MODULE

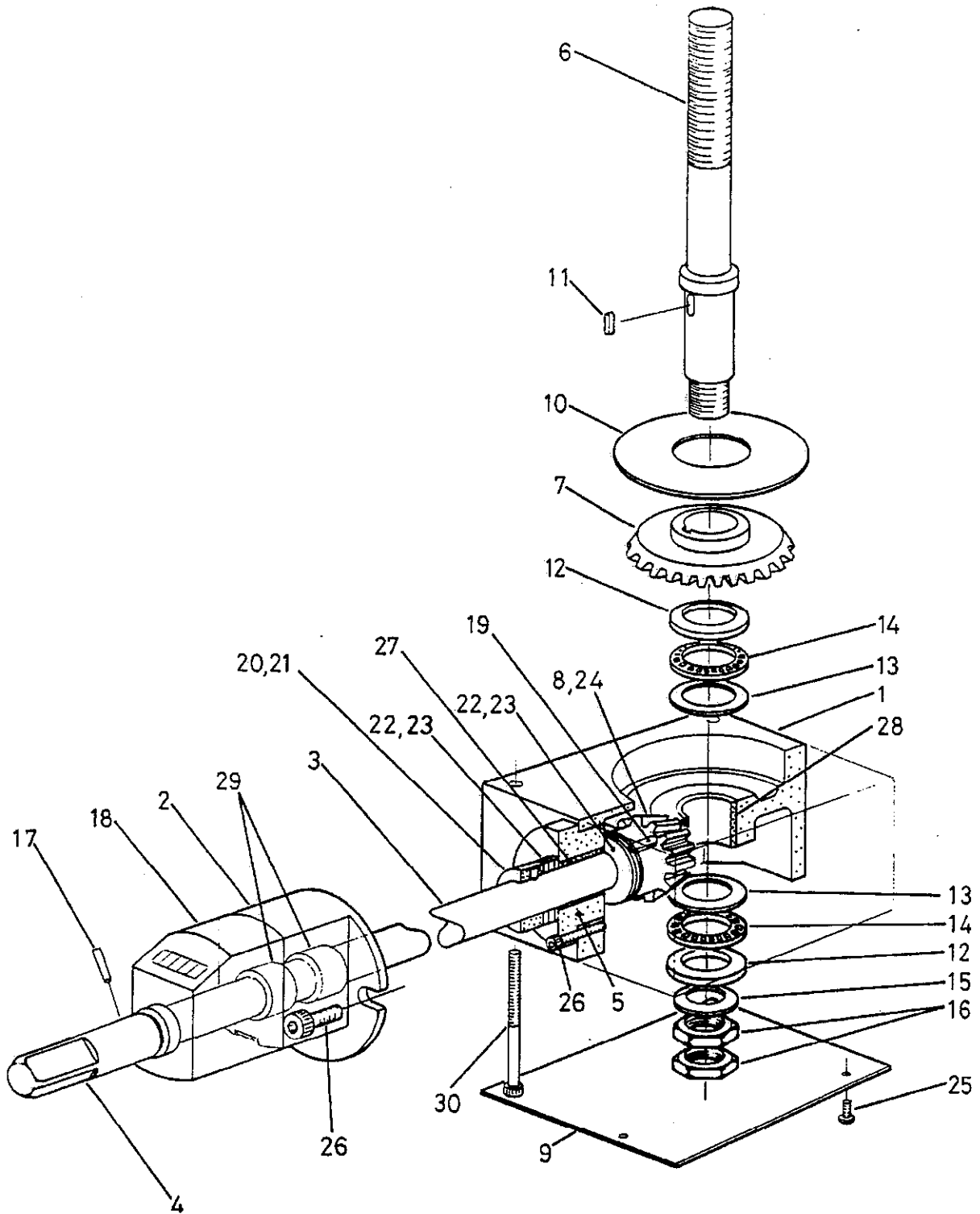

FIG 2 BOTTOM HEAD RISE AND FALL



2. BOTTOM HEAD - RISE AND FALL ADJUSTMENT

Ref No.	Description	No. Off.
1.	Bevel box for bottom head adjustment	1
2.	Bracket for cross shaft bearing	1
3.	Cross shaft for bottom head rise and fall	1
4.	Square end shaft extension	1
5.	End cap for rise and fall bevel box	1
6.	Screw for bottom head rise and fall	1
7.	Bevel gear for rise and fall	1
8.	Bevel gear for rise and fall	1
9.	Cover for bevel box	1
10.	Sealing ring	1
11.	Key 8mm x 7mm x 20mm	1
12.	'INA' Shaft washer WS 81105	2
13.	'INA' Thrust washer AS 2542	2
14.	'INA' Thrust bearing AXK 2542	2
15.	Plain washer M16	1
16.	Hexagon lock nut M16	2
17.	Taper pin	1
18.	Siko position indicator 09011 2mm	1
19.	Key 5mm x 5mm x 20mm	1
20.	Collar dia. 20mm bore	1
21.	Hexagon socket grub screw M6 x 6mm long	1
22.	'INA' Thrust washer AS 2035	4
23.	'INA' Thrust bearing AXK 2035	2
24.	External circlip dia. 16mm	1
25.	Pan head screw M4 x 10mm long	3
26.	Hexagon socket cap screw M6 x 20mm long	3
27.	Bush 25mm O/D x 20mm I/D x 25mm long	1
28.	Bush 30mm O/D x 25mm I/D x 25mm long	1
29.	bush 25mm O/D x 20mm I/D x 15mm long	2
30.	Hexagon socket cap screw M6 x 75mm long	4

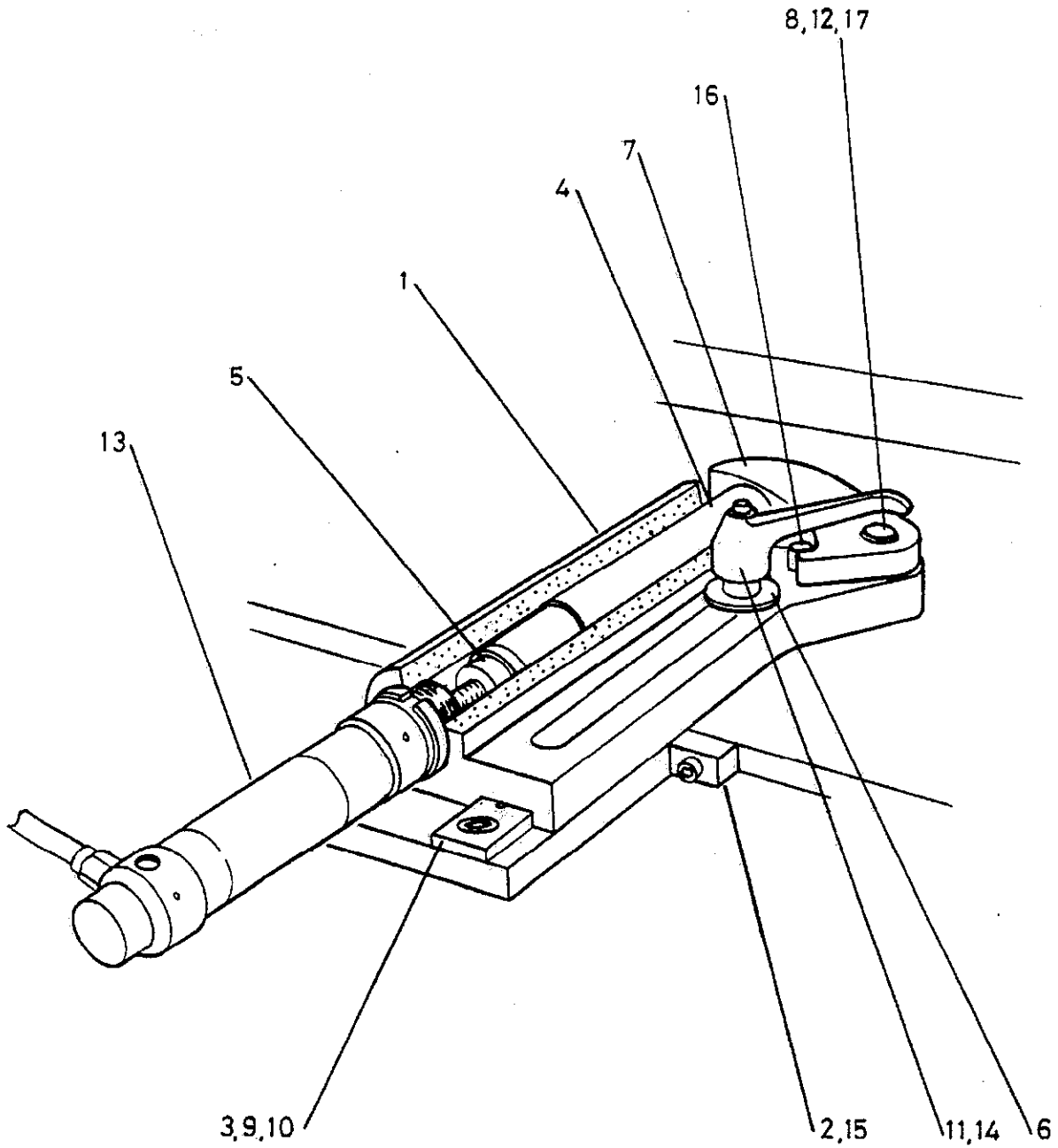

FIG 3 PNEUMATIC 'SKID' TYPE SIDE PRESSURE



BOTTOM HEAD MODULE

3. PNEUMATIC 'SKID' TYPE SIDE PRESSURE

Ref No.	Description	No Off.
1.	Bracket	1
2.	Support for bracket	1
3.	Tenon for support	1
4.	Plunger	1
5.	Sleeve	1
6.	Clamping washer	1
7.	Skid link	1
8.	Pivot link	1
9.	Tension pin dia. 8mm x 24mm long	2
10.	Hexagon socket counter sunk setscrew M8 x 16mm long	2
11.	Locking handle M12 (female)	1
12.	Bronze bush O/D 25mm x I/D 20mm x 15mm	1
13.	'Festo' single acting cylinder ref ESW-32-50P	1
14.	Stud M12 x 50mm long	1
15.	Hexagon socket capscrew M10 x 30mm long	2
16.	Plain dowel dia. 12mm x 40mm long	1
17.	Taper pin	1

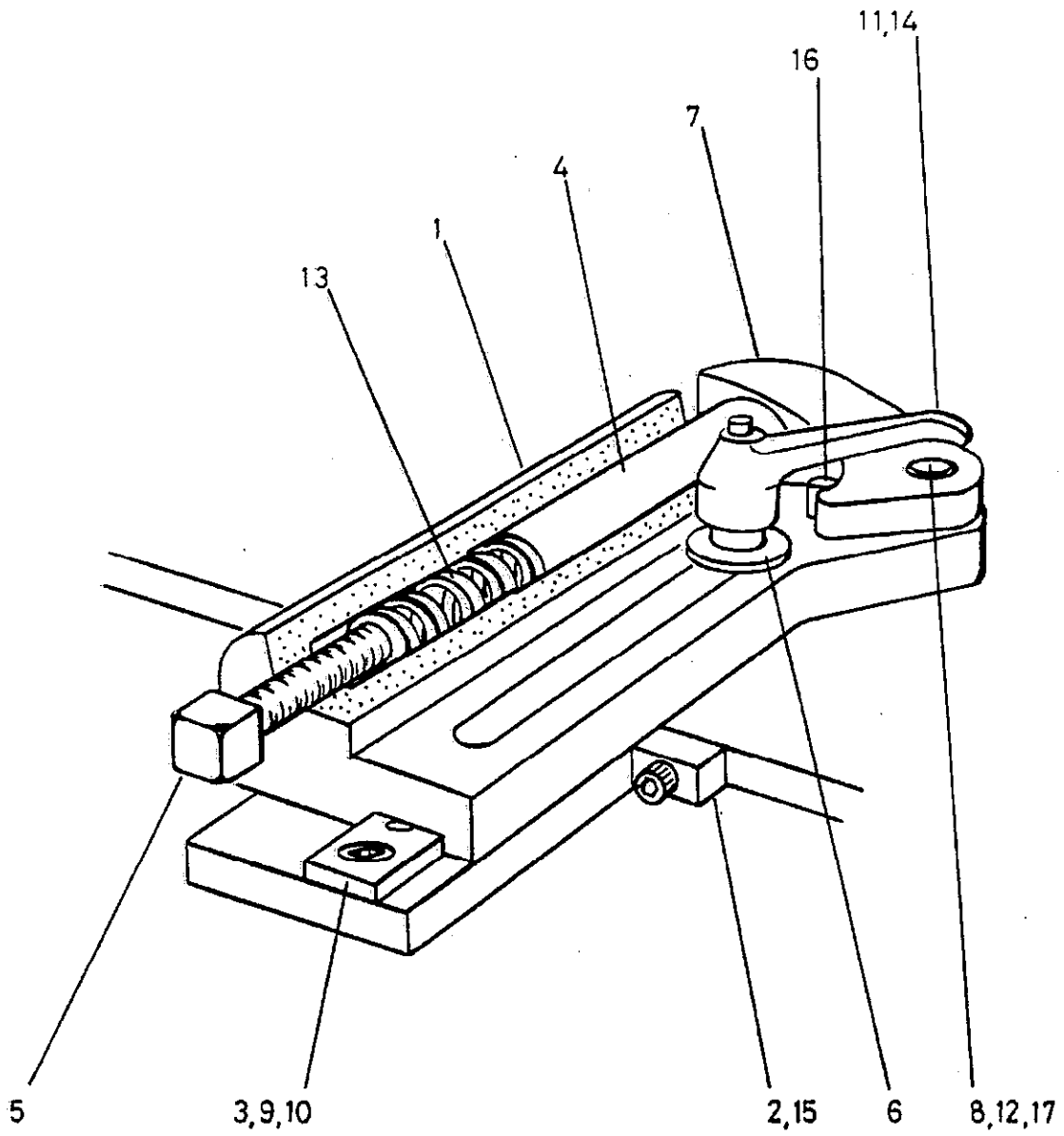

FIG 4 'SKID' TYPE SIDE PRESSURE - SPRING OPERATED



4. 'SKID' TYPE SIDE PRESSURE - SPRING OPERATED

Ref No.	Description	No Off.
1.	Bracket	1
2.	Support for bracket	1
3.	Tenon for support	1
4.	Plunger	1
5.	Tension screw	1
6.	Clamping washer	1
7.	Skid link	1
8.	Pivot link	1
9.	Tension pin dia. 8mm x 24mm long	2
10.	Hexagon socket counter sunk setscrew M8 x 16mm long	2
11.	Locking handle M12 (female)	1
12.	Bronze bush O/D 25mm x I/D 20mm x 15mm	1
13.	Compression spring 187.3mm free length, O/D 24.6mm, I/D 17.3mm, 31 coils	1
14.	Stud M12 x 50mm long	1
15.	Hexagon socket capscrew M10 x 30mm long	2
16.	Plain dowel dia. 12mm x 40mm long	1
17.	Taper pin	1

BOTTOM HEAD MODULE

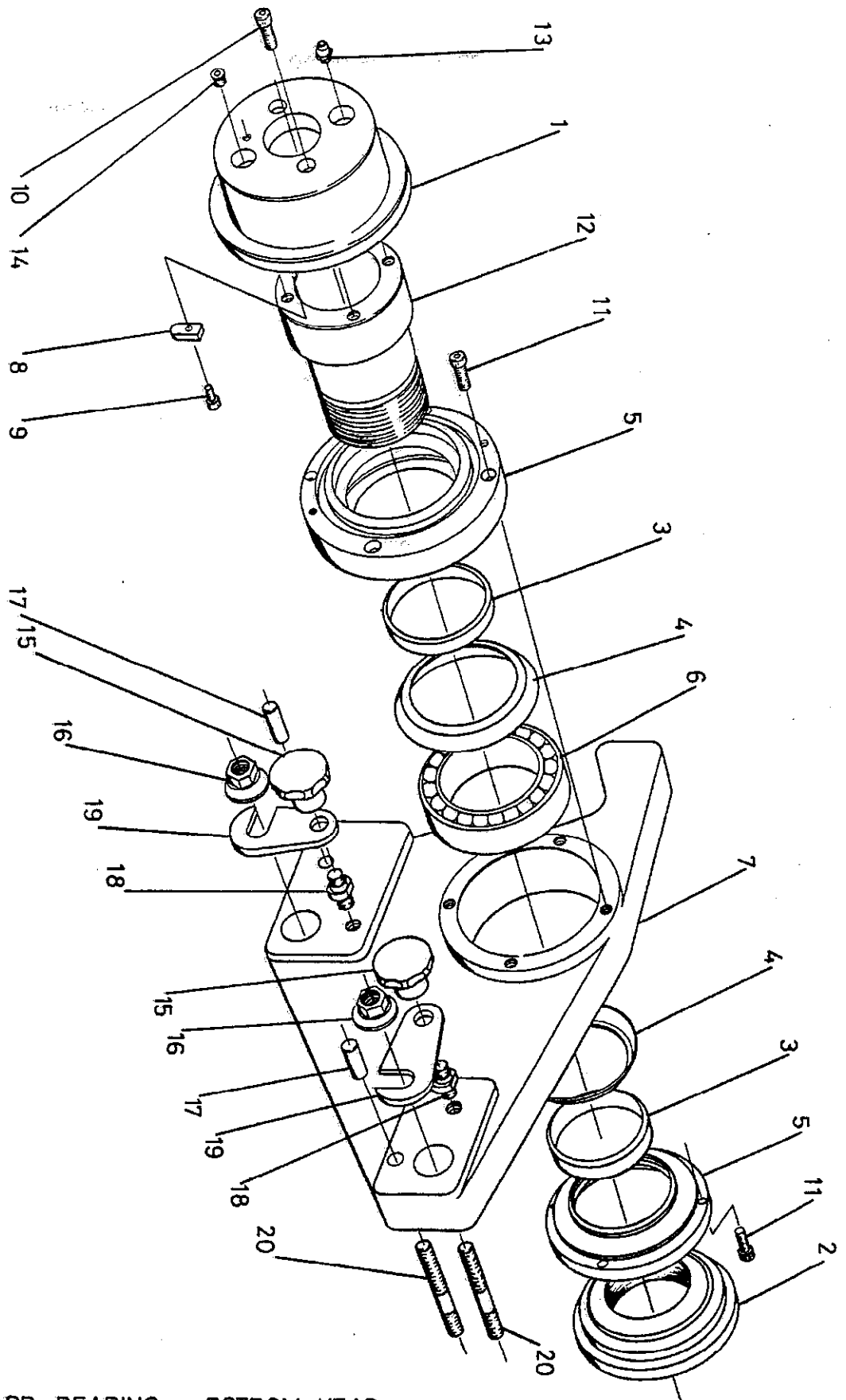

FIG 5 OUTBOARD BEARING - BOTTOM HEAD



5. OUTBOARD BEARING - BOTTOM HEADS

Ref No.	Description	No Off.
1.	Protective ring for hydrogrip sleeve	1
2.	lockout for outboard bearing	1
3.	Bearing spacer	2
4.	Disc spring 99mm O/D x 70.5mm I/D x 1mm	2
5.	End cap for outboard bearing housing	1
6.	'RHP'grease packed bearing 6211-TB-EP7	1
7.	Outboard bearing housing	1
8.	Drive key	1
9.	Hexagon socket capscrew M3 x 12mm long	1
10.	Hexagon socket capscrew M5 x 12mm long	2
11.	Hexagon socket capscrew M6 x 12mm long	8
12.	'ETP' sleeve (less front plate)	1
13.	Grease nipple } items only supplied	1
14.	Pressure release valve } with ETP sleeve	1
15.	Hand wheel M8 threaded	2
16.	Collar nut 'WDS' 404-204 M12	2
17.	Taper dowel dia. 12mm x 40mm long	2
18.	Shoulder screw	2
19.	'C' washer	2
20.	Stud M12 x 70mm long	2

SECTION 7 STAGGERED SIDE HEADS

General

This is the standard side head module with a 300mm stagger between heads. Timber is driven through by two top through feed rolls opposite the near side head followed by an opposed top/bottom roller combination. 'Siti' gearboxes at the rear, transfer the drive from the shafts to the feed rolls.

A side pressure opposite the fence side head, a top roller pressure for the fence side head and a near side head guide all help ensure timber is presented to the cutterblocks correctly.

Fence Side Head (Fig 1, Fig 2)

- 1) Isolate power at mains or at master stop.
Ensure that the machine bed is clean.
- 2) Set the fence guide (1) with a straightedge (2) against the fence guide and cutters (3) in a similar manner to that used for the First Bottom Head. If necessary adjust the spindle laterally as follows:

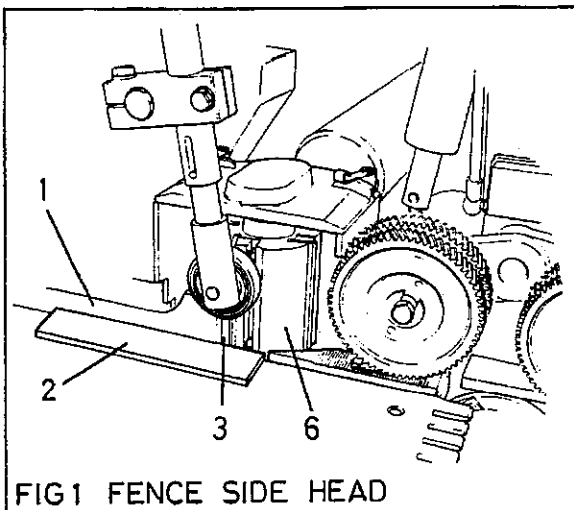

- a. Release the locking handle (4).

- b. Rotate the handscrew (5) clockwise to advance the spindle or anti-clockwise to retract the spindle.
- c. Refasten the locking handle (4).

NOTE: Maximum lateral adjustment is 33mm.

- 3) Set the axial position (height) of the cutterblock (6) as follows:

- a. Release the locking handle (4).
- b. Release the spindle clamp (7) and adjust cutter height by rotating the handscrew (8) anti-clockwise to lower or clockwise to raise the spindle.
- c. Refasten the spindle clamp (7)
- d. Refasten the locking handle (4)

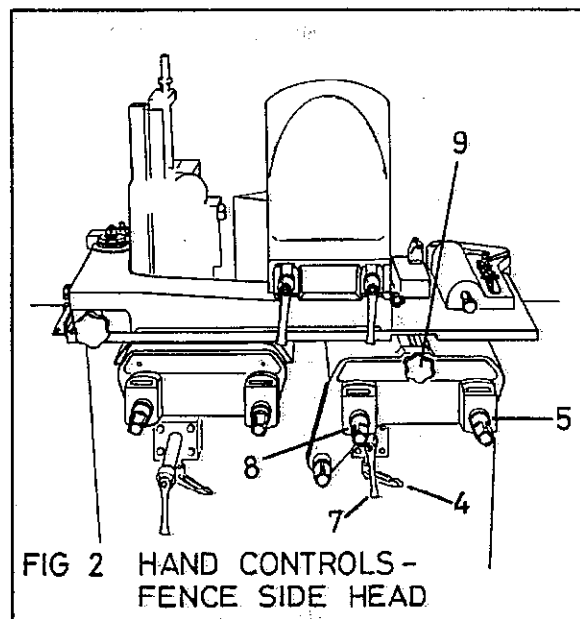

- 4) Set the sliding bedplate using adjusting knob (9) to within 5mm of the cutterblock.

Near Side Head (Fig 3, Fig 4)

- 1) Isolate power at mains or at master stop.

Ensure that the machine bed is clean.

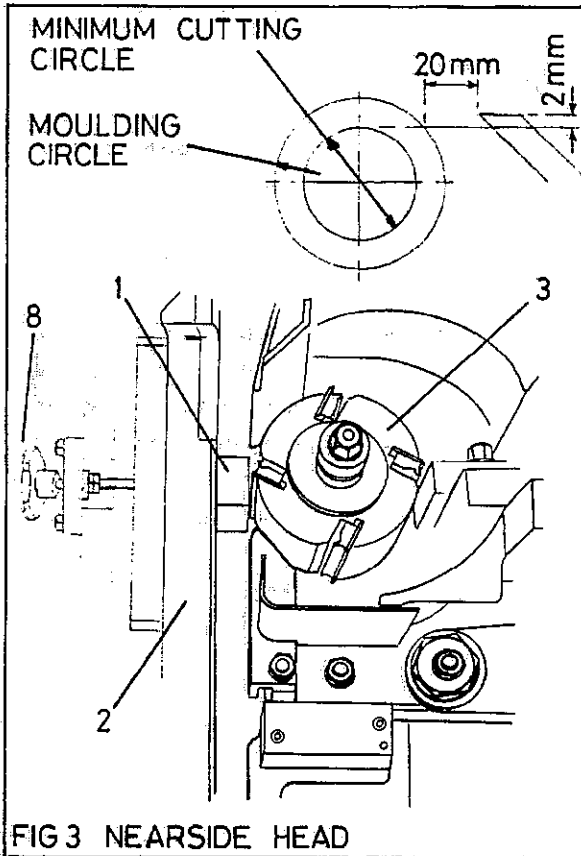

FIG 3 NEARSIDE HEAD

- 2) Check the digital readout (if fitted) using a datum block (1) of known width inserted between the fence guide (2) and cutterblock (3). The cutter blades should just touch the near side of the datum block. If necessary, reposition as follows:

- a. Release locking handle (5)
- b. Rotate handscrew (6) clockwise to advance the spindle or anti-clockwise to retract the spindle.

- c. Refasten locking handle (5)
 - d. Reset digital readout, (where fitted) to the known dimension.
- 3) Set the axial position (height) of the cutterblock (3) as follows:

- a. Release the locking handle (5)

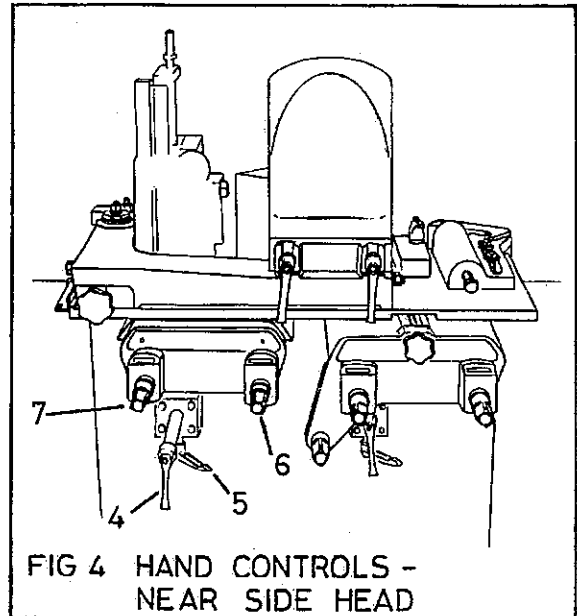

FIG 4 HAND CONTROLS - NEAR SIDE HEAD

- b. Release the spindle clamp (4) and adjust the cutter height by rotating the handscrew (7) anti clockwise to lower the spindle or clockwise to raise the spindle.
 - c. Refasten the spindle clamp (4)
 - d. Refasten locking handle (5)
- 4) Set the sliding bedplate using adjusting knob (8) to within 5mm of the cutterblock.



STAGGERED SIDE HEAD MODULE

Near Side Head Chipbreaker and Side Pressure (Fig 5, Fig 6)

The relationship between the side pad pressure and chipbreaker is factory pre-set but may, if required, be adjusted by slackening off lock nut (7) and turning stop screw (8) to adjust chipbreaker arm.

The tension on the chipbreaker arm may be varied by adjusting the screw (9) on the spring loaded standard version or by adjusting the pressure regulator for the chipbreaker arm on the pneumatic option.

(1) Set up as follows:

- a. Isolate power at mains or at master stop.
- b. Remove dust/jointer hood (4)

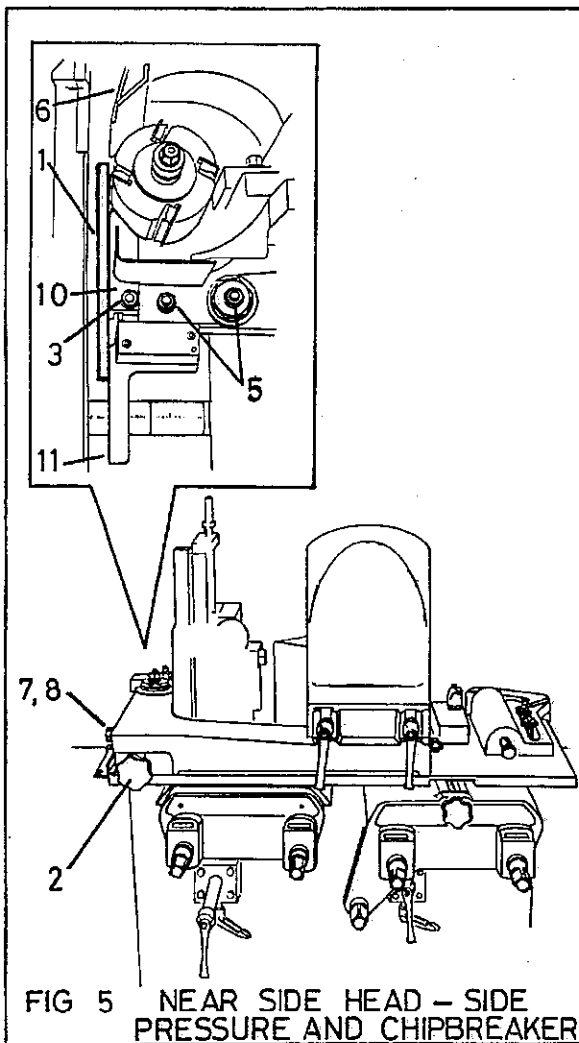

FIG 5 NEAR SIDE HEAD - SIDE PRESSURE AND CHIPBREAKER

- c. Slacken off the two locking nuts (5)
- d. With a straightedge (1) placed along the side pad pressure (10) and side guide (11) after the near side head, position the whole radial chipbreaker unit by turning the hand wheel (2) such that the cutterblades just touch the straightedge. With this set the chipbreaker should be approximately 2mm nearer the fence than the side guide.

2) Tighten up locking nuts (5)

3) Slacken off the side pad pressure locking nut (3) and reposition the pad pressure laterally so the nose is approximately 5mm from the cutterblock. When set tighten nut (3)

4) Loosen the two nuts (12) holding the chipbreaker (6) and reset this so that the nose is approximately 20mm from the cutterblock.

5) Tighten up nuts (12)

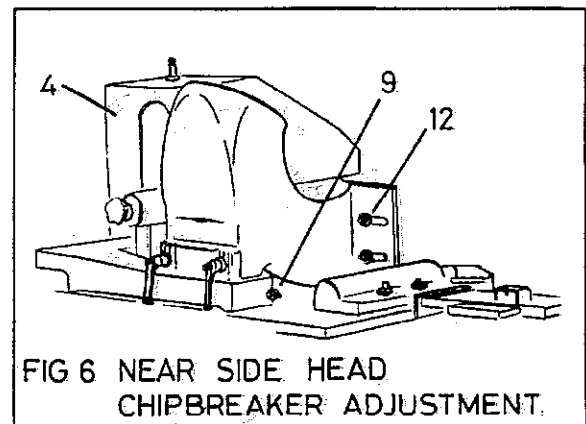

FIG 6 NEAR SIDE HEAD CHIPBREAKER ADJUSTMENT.

Side Pressure Opposite Fence Side Head (Fig 7)

The side pressure although independently adjustable is mounted to the near side head chipbreaker carrier and thus once set

maintains its relationship to the near side head. Adjust the side pressure to exert a moderate force on the timber as follows:-

- 1) Isolate power at mains or at master stop
- 2) Slacken off the two locking nuts (2)
- 3) Using a rule or timber of the correct width position side pressure (1)
- 4) Retighten nuts (2)
- 5) The tension on the skid may be varied by adjusting screw (3) clockwise to stiffen the skid movement on the spring version or by adjusting the air pressure regulator on the pneumatic optional version.

Top Roller Pressure - Fence Side Head (Fig 7)

- 1) Isolate power at mains or at master stop
- 2) Slacken screw (7) to position top roller pressure unit laterally along the bed. Retighten screw (7) when set.
- 3) Slacken screws (4 and 5) to adjust the roller pressure (6) to suit timber width and thickness. Refasten when set.

Adjustment to Top and Bottom Through Feed Rolls

For information relating to adjustment maintenance and parts refer to chapter - Driven Bed Rolls and Top Through Rolls.

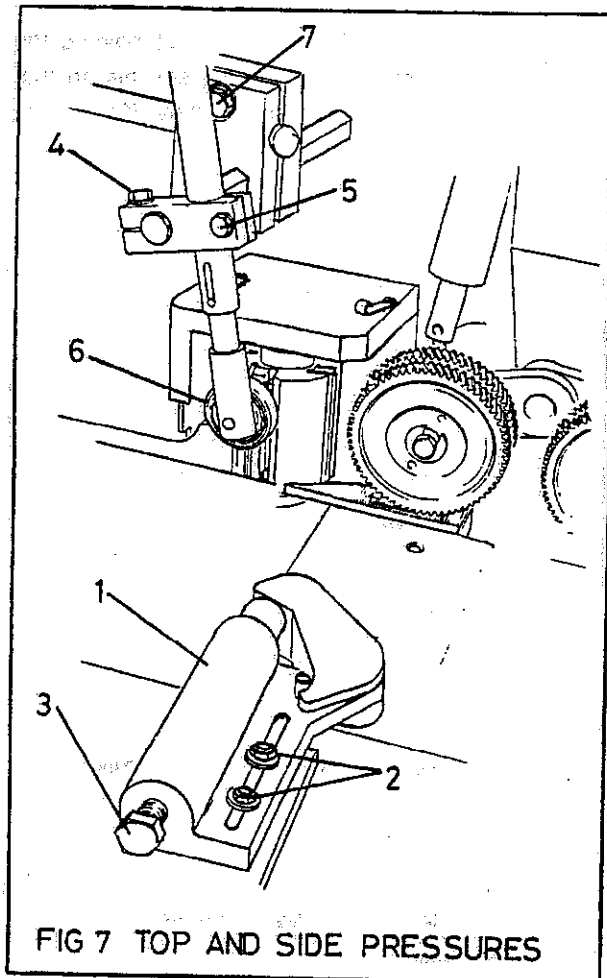

FIG 7 TOP AND SIDE PRESSURES



MOUNTING THE CUTTERBLOCKS

General

The XJS machine can be fitted with plain bore or Hydrogrip (hydraulic pressure) cutterblocks. Hydrogrip cutterblocks are used to provide an improved surface finish and allow higher feed speeds to be used. The method of fitting the two types differs.

When changing cutterblocks, be aware that the spindles for plain bore blocks have right or left hand threads, dependent on spindle location, and tighten accordingly.

The spindles are threaded as follows:

Near Side Vertical spindle - left hand thread.

Fence Side Vertical spindle - right hand thread.

The hydrogrip blocks are not screw fitting and require to be pressurised in position on the spindle. To protect the Hydrogrip cutterblock and the machine spindle in the event of hydraulic failure, it is necessary for safety drive collars to be used.

The consequence of not using the safety drive collars will result in the cutterblock seizing on the machine spindle in the event of either; The operator neglecting to pressurise the cutterblock and then running the spindle, or the Hydrogrip cutterblock sleeve losing pressure.

If a seizure occurs, the spindle and cutterblock must be returned to Wadkin for repair. An appropriate charge will be made for this service.

Two types of safety collar are used. These are a threaded safety collar; for use when full length tooling is in use on the machine spindle. A plain safety collar; for use when short length tooling is used on the machine spindle.

To change cutterblocks on Fence and Near Side Heads (Fig 1)

The method of changing cutterblocks depends on the type fitted.

- 1) Isolate power at mains or at master stop
- 2) Remove covers, guards and extraction ducts as required to allow easy unimpeded access to cutterblock
- 3) Remove cutterblocks as follow taking suitable care when handling:-

Plain Bore Type

- a. Unscrew the cutterblock nut from the spindle with the spanner/s provided. Can be right or left thread (see General)
- b. Place the spanner/s on the hexagon of the spindle and the two flat faces of the cutterblock locknut, or;
- c. Hold the spanner (top) securing the spindle firmly in position and unscrew the cutterblock locknut from the spindle with the bottom spanner.

NOTE: DO NOT use any form of percussion tool or damage to spindle bearings can result. DO NOT use a box or extension spanner.



Hydrogrip Type

- a. Release locking screw on safety collar (fig 2) and remove from spindle.

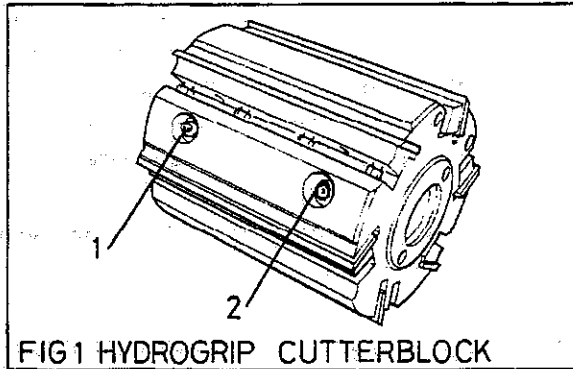

- b. Depressurise the hydrogrip cutterblock by turning the pressure release screw (2), located in a recess on the barrel of the cutterblock one quarter turn to release, using a 3mm A/F hexagon key.
- c. Slide the cutterblock from the spindle. Always leave the pressure release screw (2) undone when the cutterblock is not in use to avoid distortion to the cutterblock due to the variation in room temperatures.
- 4) To replace both types of cutterblock:
 - a. Carefully clean spindles, cutterblocks, spacers and collars before fitting new cutterblocks.
 - b. Carefully place the cutterblock on the spindle. On the hydrogrip blocks tighten pressure release screw (2), and pressurise the cutterblock by applying hydraulic pressure to the pressure nipple (1) located in a recess located on the barrel of the block (see fig 1).

- c. Fit safety collar (see fig 2) and tighten securing screw.
- d. On plain bore cutterblocks. Tighten the block to the spindle with the spanner/s provided.
- e. Turn the spindle slowly to ensure the cutterblock is free and replace covers, guards, extraction ducts etc.
- f. Operate the spindle for a short period to ensure it rotates freely and without vibration.

CAUTION

Take care not to allow the cutterblock to fall onto the spindle shoulder while fitting. This can cause damage to spindle bearings and subsequent vibration.

Safety Collars (fig 2)

Fitting procedure:

- 1) *Threaded collar*
 - a. Mount the cutterblock onto the machine spindle. Make sure the cutterblock fits up to the shoulder on the spindle.
 - b. Pressurise cutterblock to the correct working pressure.
 - c. Unscrew the pins in the threaded safety collar to the fullest extent, using the knurled heads.
 - d. Screw the collar onto the spindle, finger tight, against the end face of the cutterblock.
 - e. Reverse the collar on the threads, sufficient to allow the pins to be brought into line with corresponding

holes in the end face of the cutterblock.

- f. When in line, screw the pins into position, locating into the holes of the cutterblock.

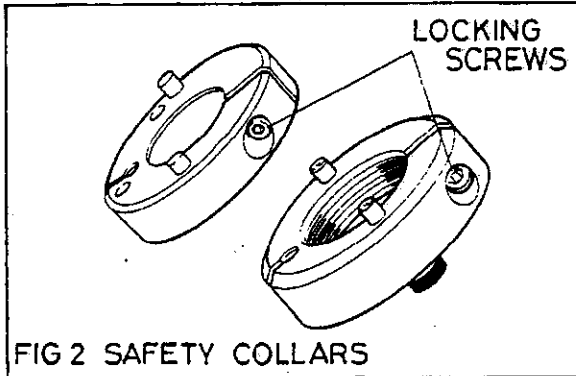

FIG 2 SAFETY COLLARS

- g. Tighten the capscrew in the collar, using an Allen Key. This causes the collar to grip the threads on the spindle.
- h. The collar will now maintain the drive to the cutterblock in the event of depressurisation.

- i. To release; reverse the procedure.

2) Plain collar

- a. Mount the cutterblock onto the machine spindle, making sure it fits up to the spindle shoulder. Pressurise cutterblock to the correct working pressure.
- b. Slide the collar with its pins facing the cutterblock along the machine spindle up to the cutterblock. Locate the pins in to the corresponding holes in the block.
- c. Tighten up the cap screw in the collar, using an Allen Key. This causes the collar to grip the spindle.
- d. The collar will now maintain the drive to the cutterblock in the event of depressurisation.
- e. To release; reverse the procedure.

MAINTENANCE

Routine Maintenance

Before proceeding with any maintenance ensure power is isolated at mains or at master stop.

Weekly (Fig 1)

It is recommended that the machine be cleaned thoroughly once a week, especially when working on hardwood or highly resinous material, to prevent choking of ventilator airways and build-up of deposits on working parts. Ensure sawdust build-up at rear of machine is clear of motors and belts.

Clean all spindles regularly and remove all remains of resin and grease. Do the same with cutterblock collars and machine tables. Check that all machine parts slide, or rotate freely.

Lightly lubricate as directed, do not over-lubricate.

If cleaning with compressed air, take care not to direct the jet onto the spindle bearing housings, moving shafts, etc., and avoid forcing dust and debris into bearings and housings.

The Side Head Slideways should be greased weekly using Wadkin grade L6 (see **Approved Lubricants**). Grease nipples for the slide way are located underneath the Near Side Head chipbreaker carrier plate. After lubrication the Heads should be adjusted to their extremes to evenly distribute the grease and prevent sawdust/resin build-up on the slideway.

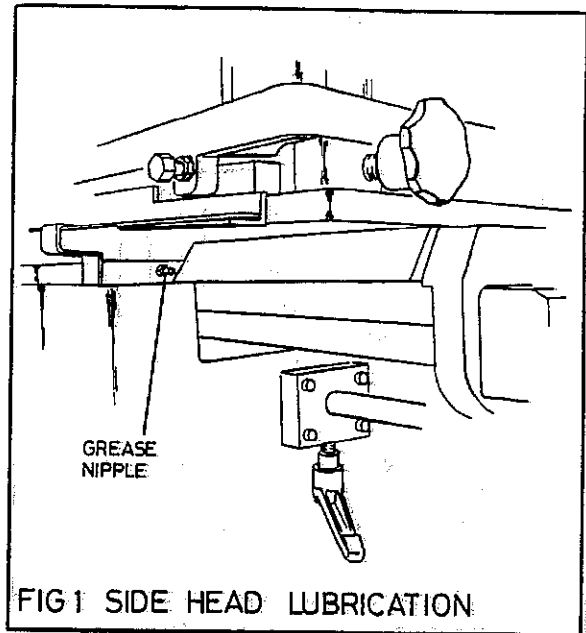

Three Monthly (Fig 2)

Electric drive motors have sealed for life bearings and are maintenance free. However the fan cowls should be removed at intervals and the fans checked for damage, check for excessive end float, signs of overheating etc. If a cowl itself is damaged it should be replaced. Check tension and condition of drive belts. The belts should be capable of being depressed approximately 1 1/2 to 2cm per metre of span by application of average thumb pressure of 2.2 - 3.2 kgf (5-7 bf). If necessary retension (see **vee Belt Drive Tensioning**). Unscrew the two nuts (1) retaining the cover (2) over the bevel gears for the motor rise and fall (near the side head motors). Clean and regrease using Wadkin grade L6. Replace and secure cover.

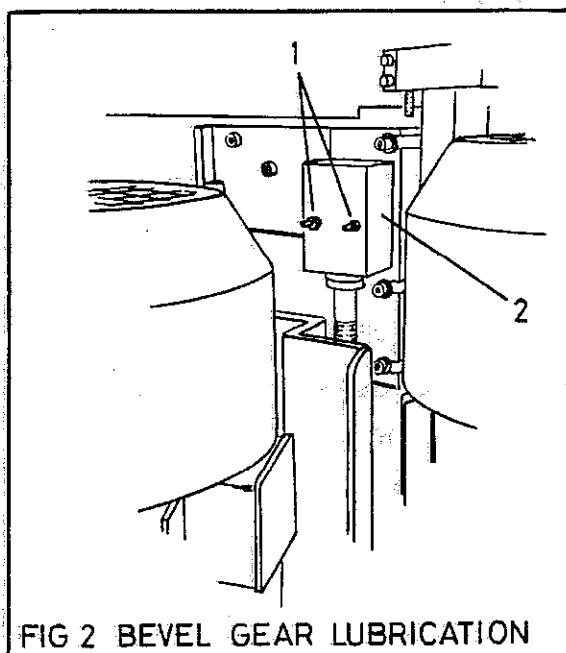

FIG 2 BEVEL GEAR LUBRICATION

Vee Belt Drive Tensioning (Fig 3)

Both fence and side head motors are mounted in the same way and adjustment to each is similar.

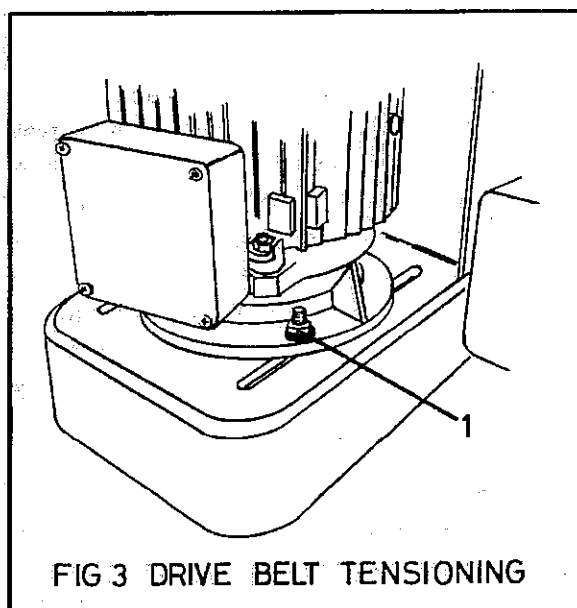

FIG 3 DRIVE BELT TENSIONING

- 2) Tension the belts using an outward force on the motor
- 3) Tighten motor clamping bolts

Replacing Vee Belts (Fig 3)

Drive belts must be replaced as a set to obtain correct drive performance.

- 1) Relieve tension on the drive belts by slackening off the four bolts (1)
- 2) Slide the motor towards machine until belts may be removed
- 3) Fit new belts (check size, type and reference)
- 4) Retension and secure bolts.

- 1) Slacken off the four motor clamping bolts (1)

ILLUSTRATED PARTS LIST

CONTENTS

1. Fence side head carriage adjustments
2. Spindle barrel locks for fence and near side heads
3. Near side head carriage adjustments
4. Motor rise and fall for side heads
5. 'Skid' type side pressure – spring operated
6. 'Skid' type side pressure – pneumatic operated
37. Near side head chipbreaker MKIII.

IMPORTANT :- When ordering spares always quote model and machine number

STAGGERED SIDE HEAD MODULE

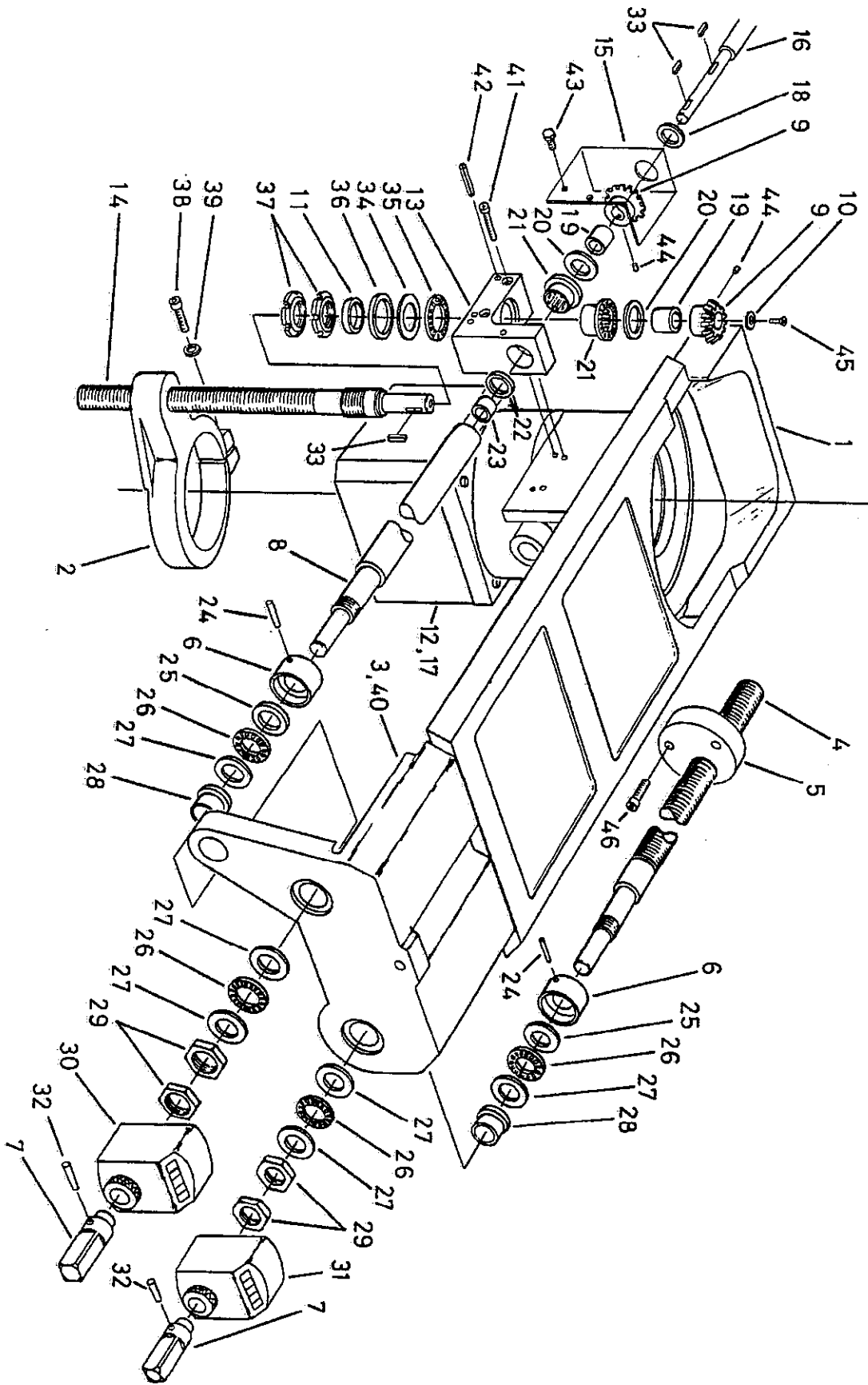

FIG 1 FENCE SIDE HEAD CARRIAGE ADJUSTMENTS



STAGGERED SIDE HEAD MODULE

1. FENCE SIDE HEAD CARRIAGE ADJUSTMENTS

Ref No.	Description	No. Off
1.	Fence side head carriage 105mm dia. barrel	1
2.	Adjusting nut for spindle barrel	1
3.	Carriage extension	1
4.	Horizontal adjustment screw	1
5.	Nut for horizontal adjustment screw	1
6.	Collar	2
7.	Square end shaft extension	2
8.	Horizontal adjustment shaft for spindle rise and fall	1
9.	Bevel gear	2
10.	Special washer	1
11.	Spacer	1
12.	Carriage extension	1
13.	Bevel gear housing	1
14.	Adjusting screw for spindle rise and fall	1
15.	Bevel gear housing cover	1
16.	Extension shaft for horizontal rise and fall	1
17.	Hexagon socket capscrew M8 x 30mm long	4
18.	Grommet to suit 25mm hole, 20mm shaft	1
19.	'Nadella' bearing sleeve IM 15 x 20 x 20	2
20.	'Nadella' thrust plate CP 32035	2
21.	'Nadella' bearing RAX 720	2
22.	'Nadella' seal ET 2026	1
23.	'Nadella' bearing sleeve IM 15 x 20 x 16.4	1
24.	Taper pin No3	2
25.	'INA' Shaft washer WS 81104	2
26.	'INA' Thrust bearing AXK 2035	6
27.	'INA' Thrust washer AS 2035	6
28.	Bronze flanged bush 26mm O/D, 20mm I/D, 20mm long	2
29.	Locking nut M20 x 1.5p	4
30.	'Siko' dial indicator 0902 E (4mm)	1
31.	'Siko' dial indicator 0902 I (4mm)	1
32.	Taper pin No 0	2
33.	Key 5mm x 5mm x 2mm long	3
34.	'Nadella' thrust plate CP 32542	1
35.	'Nadella' thrust bearing AX 2542	1
36.	'Gaco' Lip seal SMIM 32427	1
37.	Notched nut M24 x 1.5p	2
38.	Hexagon socket capscrew M10 x 50mm long	1
39.	Plain washer M10	1
40.	Hexagon socket capscrew M10 x 35mm long	4
41.	Hexagon socket capscrew M8 x 45mm long	2

STAGGERED SIDE HEAD MODULE

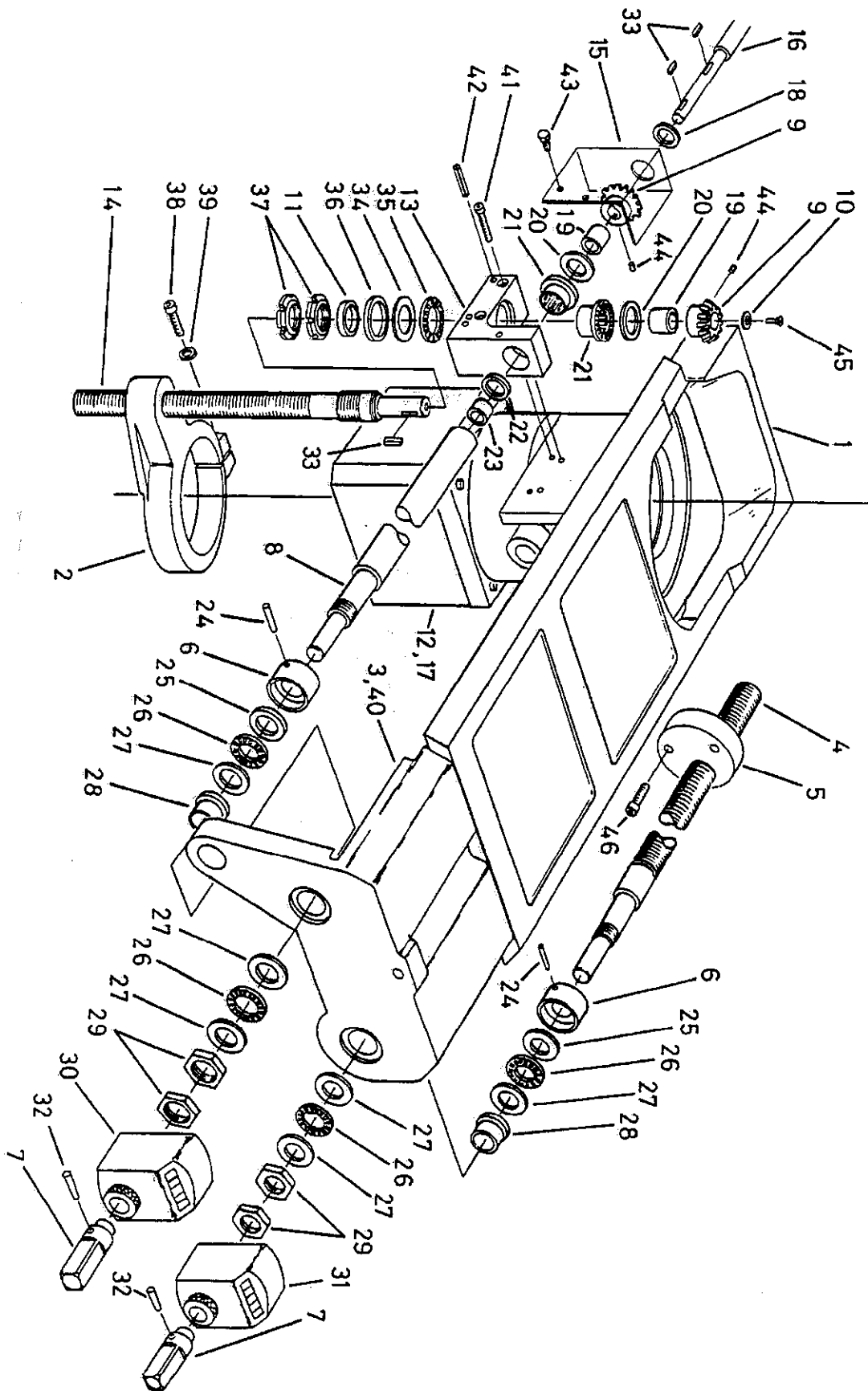

FIG 1 FENCE SIDE HEAD CARRIAGE ADJUSTMENTS



STAGGERED SIDE HEAD MODULE

1. FENCE SIDE HEAD CARRIAGE ADJUSTMENTS (CONT....)

Ref No.	Description	No Off.
42.	Tension pin 6mm dia x 50mm long	2
43.	Hexagon set screw M6 x 10mm long	2
44.	Hexagon socket grubscrew M6 x 6mm long	2
45.	Hexagon socket countersunk screw M8 x 16mm long	1
46.	Hexagon socket capscrew M8 x 40mm long	2

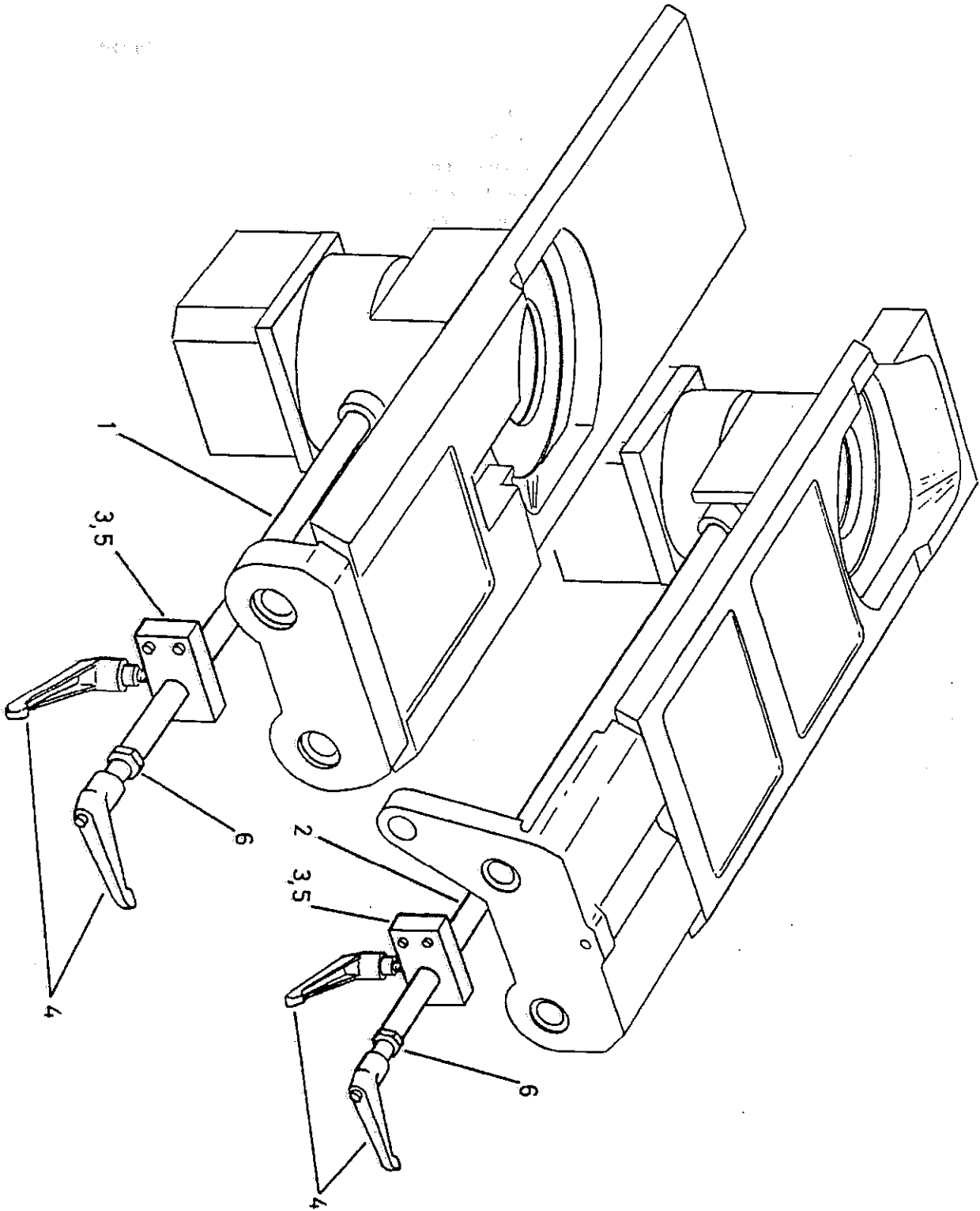

FIG 2 SPINDLE BARREL LOCKS FOR FENCE AND NEAR SIDE HEADS



STAGGERED SIDE HEAD MODULE

2. SPINDLE BARREL LOCKS FOR FENCE AND NEAR SIDE HEADS

Ref No.	Description	No.off
1.	Shaft for near side head barrel lock	1
2.	Shaft for fence side head barrel lock	1
3.	Block for side head clamps	2
4.	Bristol lock handle (male) M12 x 25	4
5.	Hexagon socket capscrew M8 x 40mm long	4
6.	Hexagon lock nut M12	2

STAGGERED SIDE HEAD MODULE

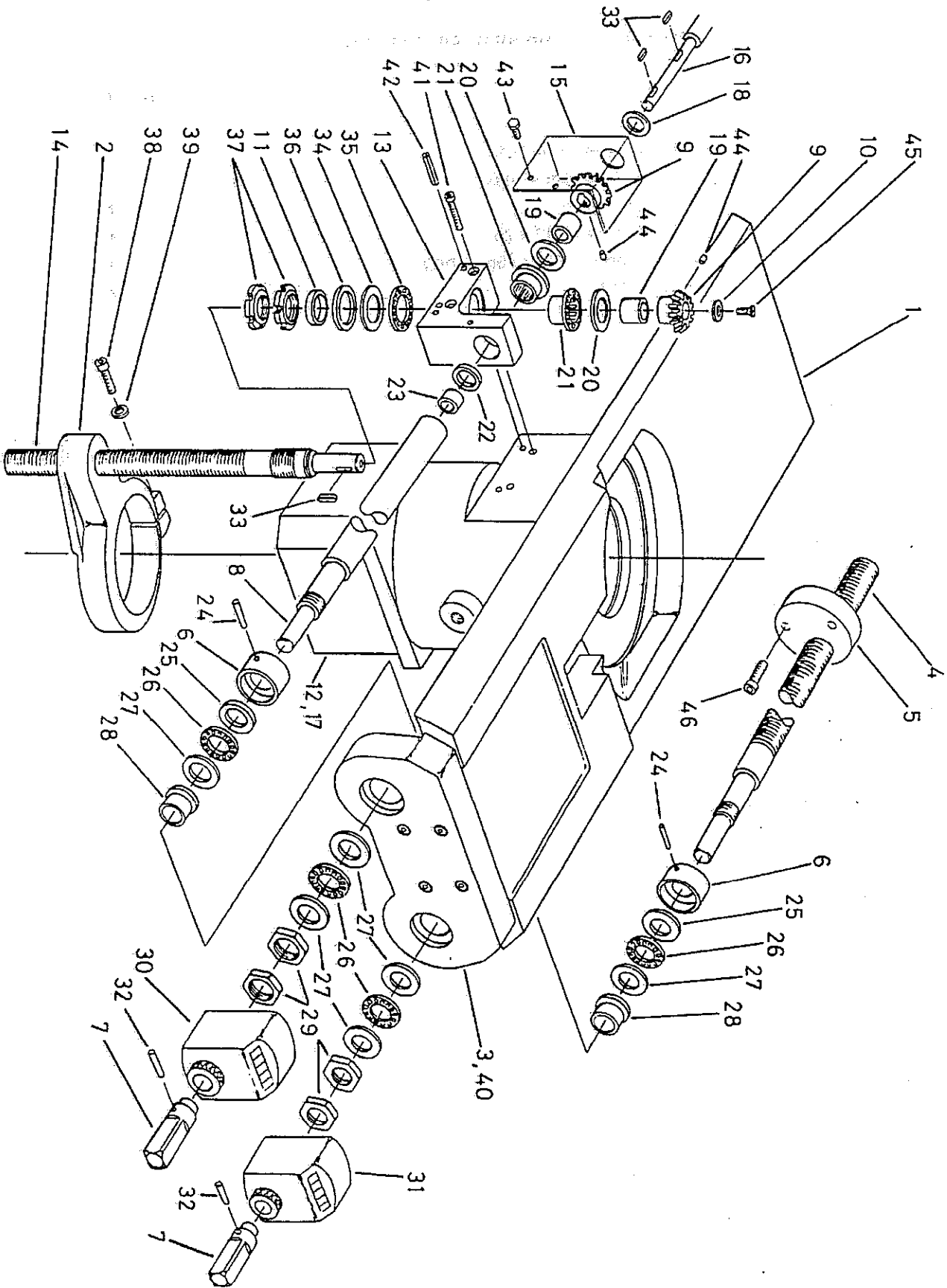

FIG 3 NEAR SIDE HEAD CARRIAGE ADJUSTMENTS



3. NEAR SIDE HEAD CARRIAGE ADJUSTMENTS

Ref No.	Description	No. off
1.	Near side head carriage 105mm dia barrel	1
2.	Adjusting nut for spindle barrel	1
3.	Carriage extension	1
4.	Horizontal adjustment screw	1
5.	Nut for horizontal adjustment screw	1
6.	Collar	2
7.	Square end shaft extension	2
8.	Horizontal adjustment shaft for spindle rise and fall	1
9.	Bevel gear	2
10.	Special washer	1
11.	Spacer	1
12.	Carriage extension	1
13.	Bevel gear housing	1
14.	Adjusting screw for spindle rise and fall	1
15.	Bevel gear housing cover	1
16.	Extension shaft for horizontal rise and fall	1
17.	Hexagon socket capscrew M8 x 30mm long	4
18.	Grommet to suit 25mm hole, 20mm shaft	1
19.	'Nadella' bearing sleeve IM 15 x 20 x 20	2
20.	'Nadella' thrust plate CP 32035	2
21.	'Nadella' bearing RAX 720	2
22.	'Nadella' seal ET 2026	1
23.	'Nadella' bearing sleeve IM 15 x 20 x 16.4	1
24.	Taper pin No 3	2
25.	'INA' shaft washer WS 81104	2
26.	'INA' thrust bearing AXK 2035	6
27.	'INA' thrust washer AS 2035	6
28.	Bronze flanged bush 26mm O/D, 20mm I/D, 20mm long	2
29.	Locking nut M20 x 15p	4
30.	'Siko' dial indicator 0902 E (4mm)	1
31.	'Siko' dial indicator 0902 I (4mm)	1
32.	Taper pin No 0	2
33.	Key 5mm x 5mm x 20mm long	3
34.	'Nadella' thrust plate CP 32542	1
35.	'Nadella' thrust bearing AX 2542	1
36.	'Gaco' lip seal SMIM 32427	1
37.	Notched nut M24 x 1.5p	2
38.	Hexagon socket capscrew M10 x 50mm long	1
39.	Plain washer M10	1
40.	Hexagon socket capscrew M10 x 45mm long	4
41.	Hexagon socket capscrew M8 x 45mm long	2
42.	Tension pin 6mm dia x 50mm long	2

STAGGERED SIDE HEAD MODULE

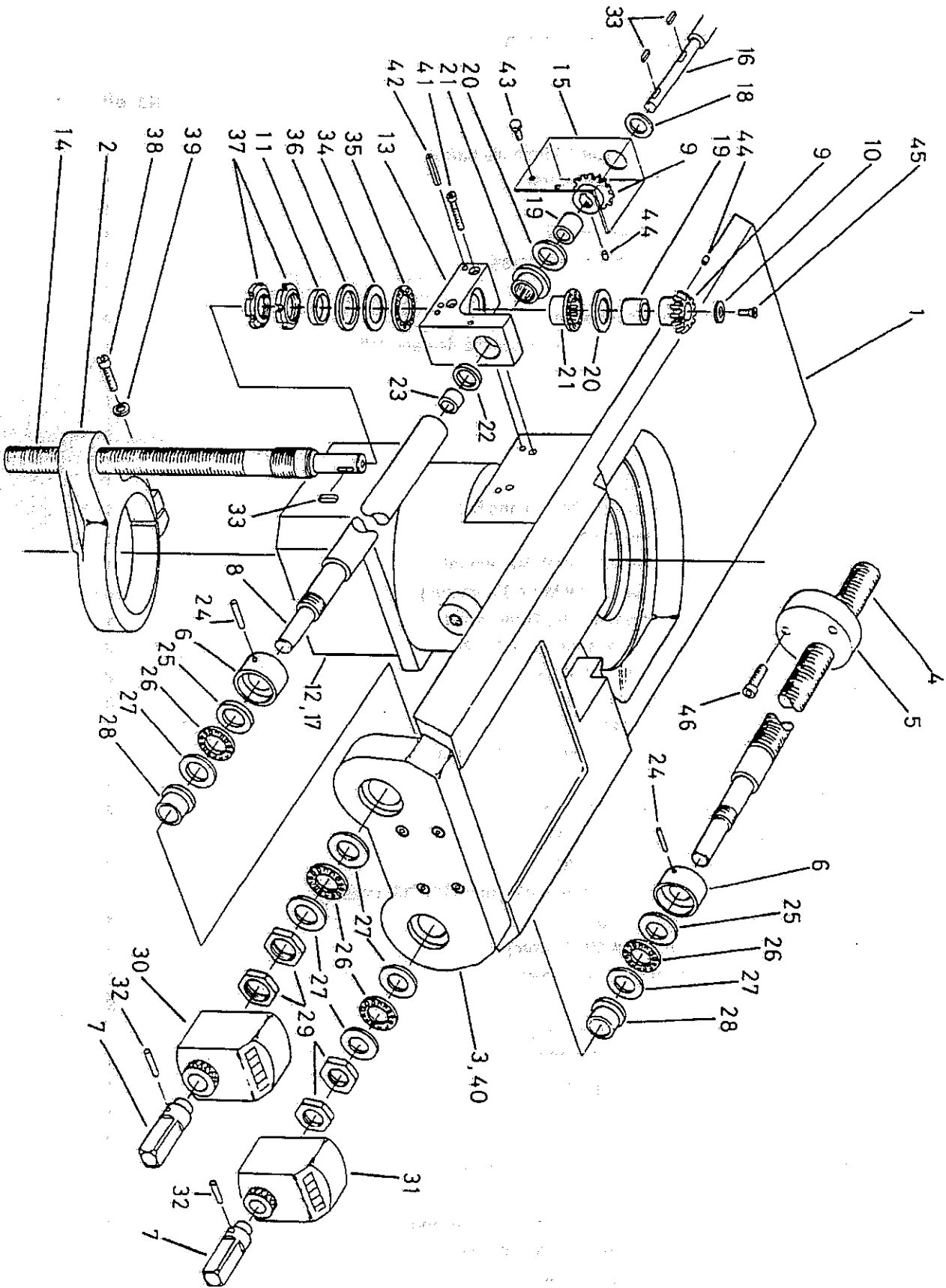

FIG 3 NEAR SIDE HEAD CARRIAGE ADJUSTMENTS



3. NEAR SIDE HEAD CARRIAGE ADJUSTMENTS (CONT...)

Ref No.	Description	No Off.
43.	Hexagon set screw M6 x 10mm long	2
44.	Hexagon socket grubscrew M6 x 6mm long	2
45.	Hexagon socket screw countersunk screw M8 x 16mm long	1
46.	Hexagon socket capscrew M8 x 40mm long	2

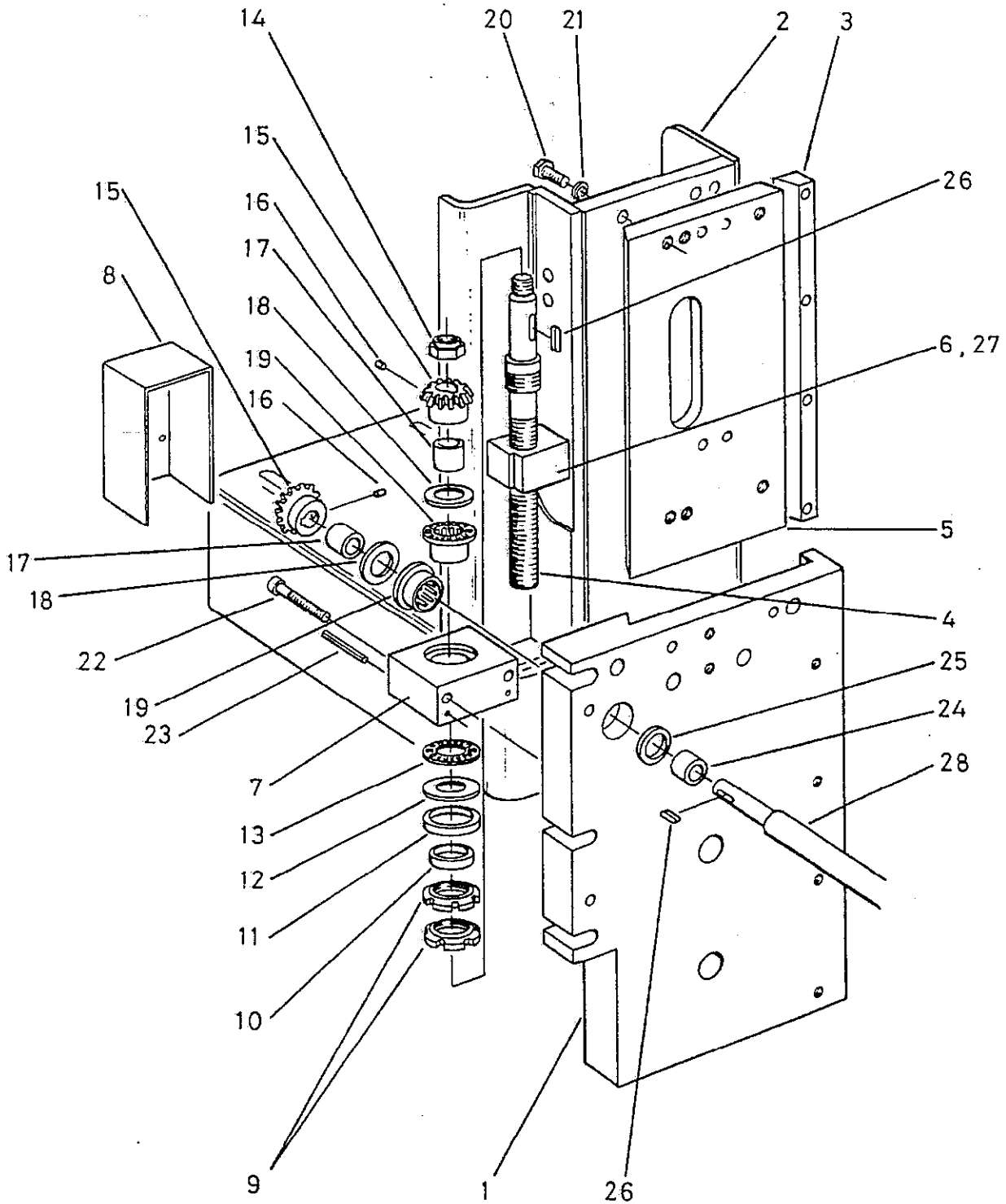

FIG 4 MOTOR RISE AND FALL FOR SIDE HEADS



4. MOTOR RISE AND FALL FOR SIDE HEADS

Ref No.	Description	No. off.
1.	Slideway for side head motor mounting	1
2.	Bracket for mounting side head motors	1
3.	Wear strip	1
4.	Vertical adjustment screw	1
5.	Slide for mounting side head motor	1
6.	Nut for side head motor rise and fall	1
7.	Bearing block	1
8.	Cover for bevel gears	1
9.	Notched nut M24 x 1.5p	2
10.	Spacer	1
11.	'Gaco' lip seal SMIM 32427	1
12.	'Nadella' thrust plate CP 32542	1
13.	'Nadella' thrust bearing AX 2542	1
14.	Self locking nut M12	1
15.	Bevel gear	2
16.	Hexagon socket grubscrew M6 x 6mm long	2
17.	'Nadella' bearing sleeve IM 15 x 20 x 20	1
18.	'Nadella' thrust plate CP 32035	1
19.	'Nadella' bearing RAX 720	2
20.	Hexagon head setscrew M12 x 35mm long	4
21.	Spring washer M12	4
22.	Hexagon socket capscrew M8 x 55mm long	2
23.	Tension pin dia. 6mm x 50mm	2
24.	'Nadella' bearing sleeve IM 15 x 20 x 20	2
25.	'Nadella' seal ET 2026	1
26.	Key 5mm x 5mm x 20mm long	1
27.	Hexagon socket capscrew M10 x 25mm long	2
28.	Extension shaft for horizontal rise and fall	1

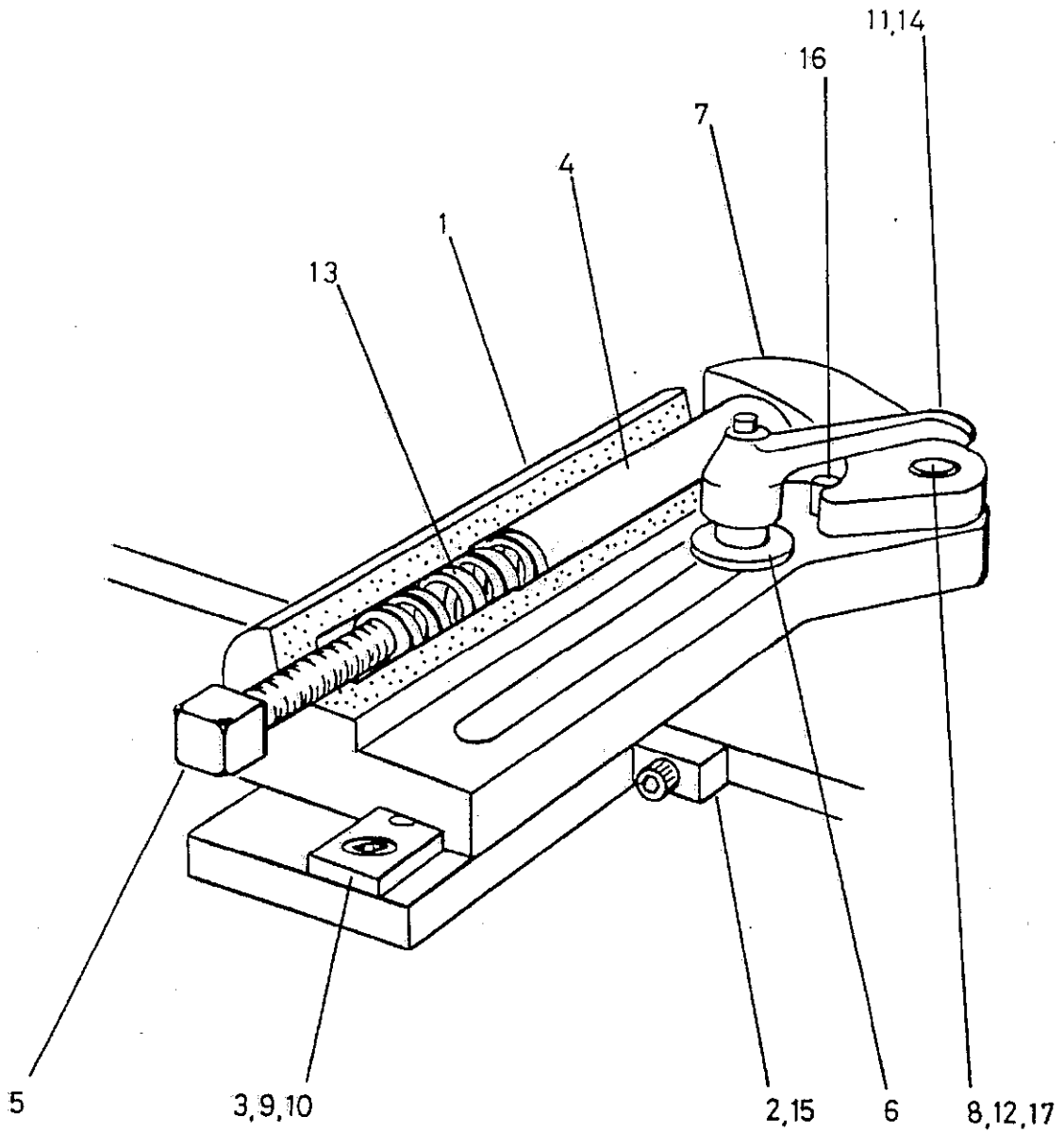

FIG 5 'SKID' TYPE SIDE PRESSURE - SPRING OPERATED



STAGGERED SIDE HEAD MODULE

5. 'SKID' TYPE SIDE PRESSURE - SPRING OPERATED

Ref No.	Description	No Off.
1.	Bracket	1
2.	Support for bracket	1
3.	Tenon for support	1
4.	Plunger	1
5.	Tension screw	1
6.	Clamping washer	1
7.	Skid link	1
8.	Pivot link	1
9.	Tension pin dia. 8mm x 24mm long	2
10.	Hexagon socket counter sunk setscrew M8 x 16mm long	2
11.	Locking handle M12 (female)	1
12.	Bronze bush O/D 25mm x 1/D 20mm x 15mm	1
13.	Compression spring 187.3mm free length, O/D 24.6mm, 1/D 17.3mm, 31 coils	1
14.	Stud M12 x 50mm long	1
15.	Hexagon socket capscrew M10 x 30mm long	2
16.	Plain dowel dia. 12mm x 40mm long	1
17.	Taper pin	1

STAGGERED SIDE HEAD MODULE

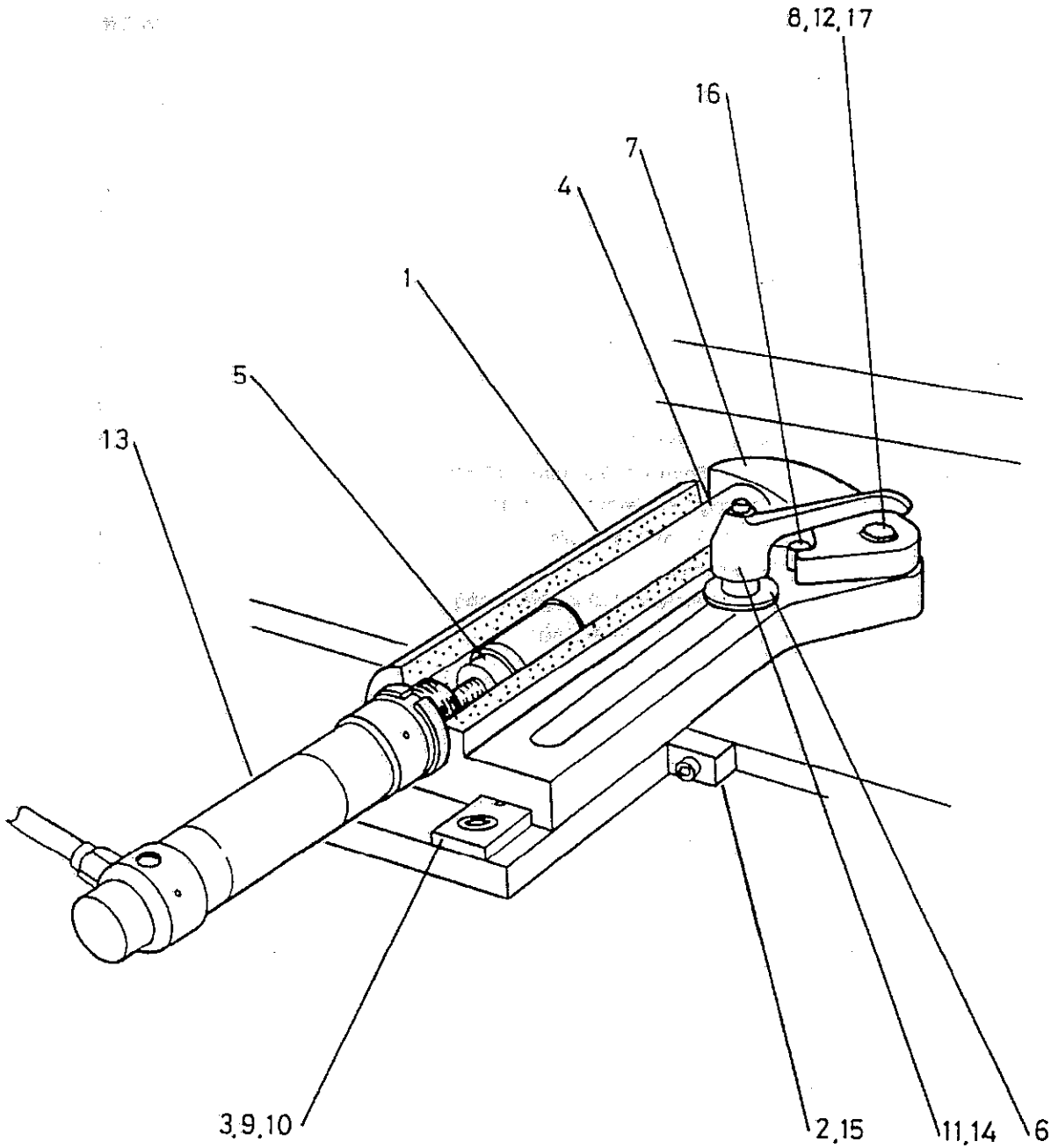

FIG 6 PNEUMATIC 'SKID' TYPE SIDE PRESSURE



STAGGERED SIDE HEAD MODULE

6. PNEUMATIC 'SKID' TYPE SIDE PRESSURE

Ref No.	Description	No Off.
1.	Bracket	1
2.	Support for bracket	1
3.	Tenon for support	1
4.	Plunger	1
5.	Sleeve	1
6.	Clamping washer	1
7.	Skid link	1
8.	Pivot link	1
9.	Tension pin dia. 8mm x 24mm long	2
10.	Hexagon socket counter sunk setscrew M8 x 16mm long	2
11.	Locking handle M12 (female)	1
12.	Bronze bush O/D 25mm x I/D 20mm x 15mm	1
13.	'Festo' single acting cylinder ref ESW-32-5OP	1
14.	Stud M12 x 50mm long	1
15.	Hexagon socket capscrew M10 x 30mm long	2
16.	Plain dowel dia. 12mm x 40mm long	1
17.	Taper pin	1

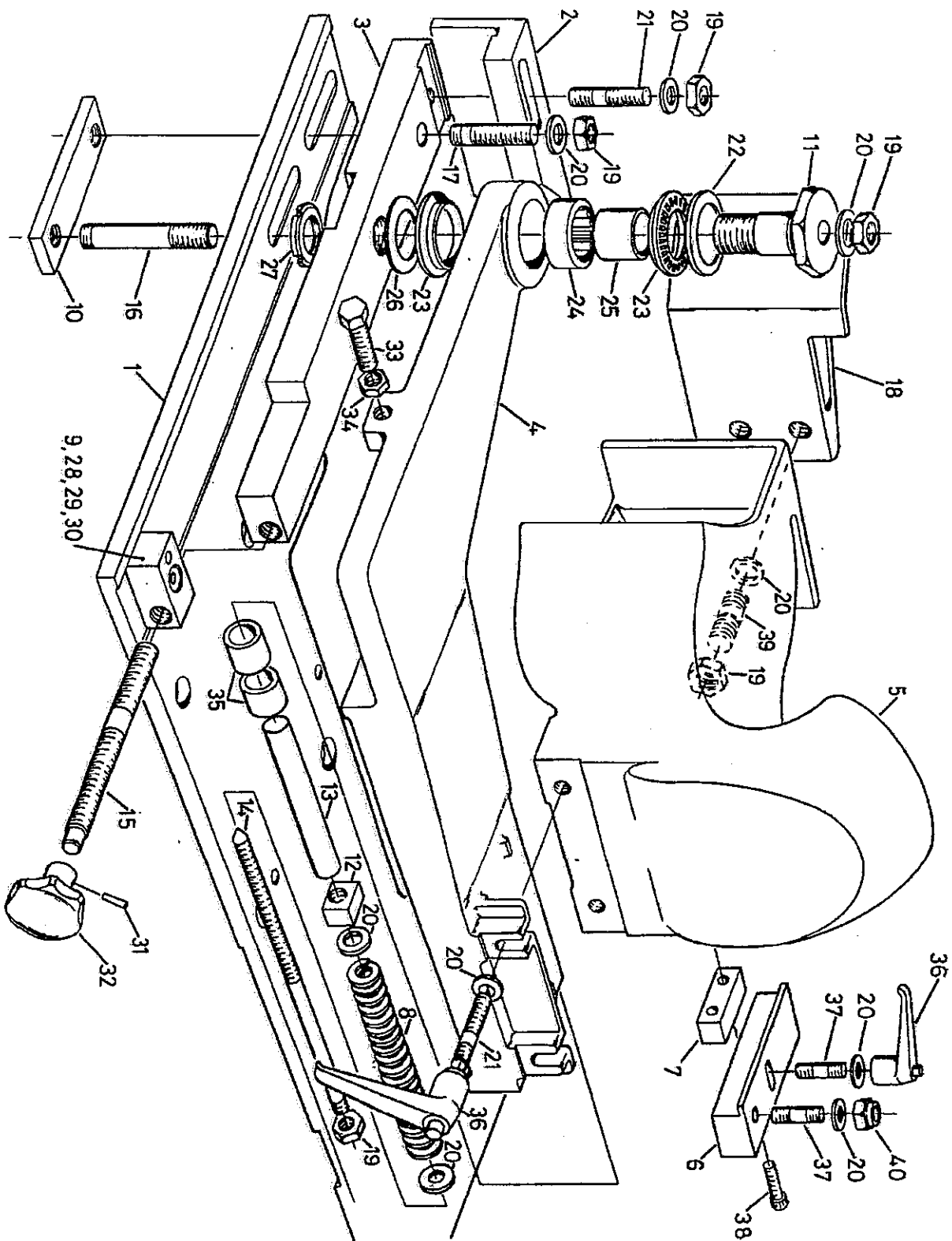

FIG 37. NEAR SIDE HEAD CHIPBREAKER MK III

**37. NEAR SIDE HEAD CHIPBREAKER MK III**

Ref No.	Description	No. off
1	Plate for mounting near side head chipbreaker	1
2	Pad for near side head side guide	1
3	Block for mounting near side head chipbreaker	1
4	Arm for near side head chipbreaker	1
5	Hood for near side head	1
6	Latch for near side head chipbreakers	1
7	Block for retaining near side head chipbreaker	1
8	Spring	1
9	Block for near side head adjustment	1
10	Clamp for near side head adjustment	1
11	Bolt for near side head chipbreaker pivot	1
12	Nut for near side head chipbreaker spring	1
13	Plunger	1
14	Guide for spring	1
15	Screw for side guide adjustment	1
16	Stud for pivot bolt	1
17	Stud for block	1
18	Shoe for chipbreaker	1
19	Nut M12	6
20	Plain washer M12	11
21	Stud M12 x 55mm long	3
22	'INA' Thrust washer LS-3552	1
23	'INA' Thrust bearing AXW - 30	2
24	'INA' Needle bearing HK 3020	1
25	'INA' Inner ring IR25 x 30 x 30	1
26	(INA) Thrust washer AS-3047	1
27	Notch nut	1
28	Tension pin dia 8mm x 40mm long	1
29	Hexagon socket cap screw M10 x 35mm long	1
30	'helicoil' insert M12	1
31	Taper pin No. 1	1
32	Handwheel	1
33	Hexagon head setscrew M12 x 35mm long	1
34	Locknut M12	1
35	Oilite bush	2
36	Locking handle	3
37	Stud m12 x 65mm long	2
38	Hexagon socket capscrew M12 x 30mm long	2
39	Stud M12 x 45mm long	2
40	Self locking nut M12	1

SECTION 8 CLOSE COUPLED STAGGERED SIDE HEADS

General

This optional side head module has the heads staggered 80mm. The timber is driven through by two top through feed rolls opposite the near side head, followed by an opposed top/bottom roller combination. 'Siti' gearboxes at the rear, transfer the drive from the shafts to the feedrolls via a cardan prop shaft.

Side pressures, side guides and top roller pressures all help ensure timber is presented correctly to the cutterheads.

Fence Side Head (Fig 1)

- 1) Isolate power at mains or at master stop.
Ensure machine bed is clean.

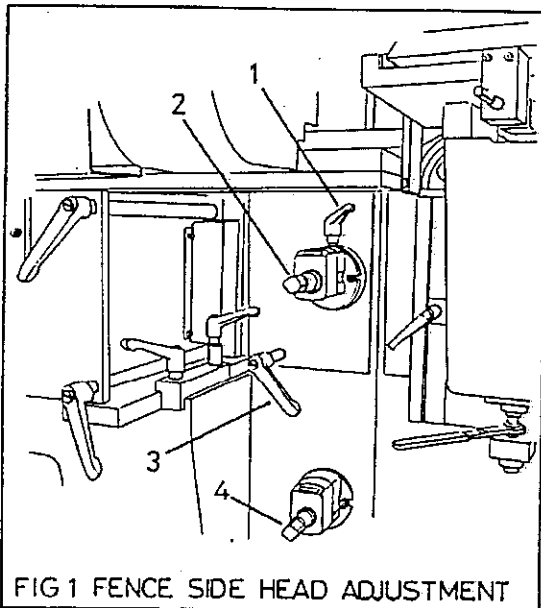

- 2) To adjust the spindle laterally proceed as follows:
 - a. Release the locking handle (1).
 - b. Rotate the handscrew (2) clockwise to advance the spindle towards the fence and anti-clockwise to retract the spindle away from the fence.

- c. When set refasten locking handle (4).
- 3) Set the axial position (height) of the cutterblock as follows:
 - a. Release the spindle barrel lock (3).
 - b. Turn the handscrew (4) clockwise to lower or anti-clockwise to raise the spindle.
 - c. When set refasten locking handles.

Near Side Head (Fig 2)

Because of the close distance (80mm) between the side head spindles movement of the near side head also moves the bedplate (between the side heads) at 45° degrees.

- 1) Horizontal spindle adjustment.

To avoid any damage to the tooling, horizontal adjustments should be carried out in the following order:

Near side head carriage out - adjust spindle first then the side guide.

Near side head carriage in - adjust the side guide first then the spindle.

Refer to Section 20 for side guide adjustment.

Ensure machine power is isolated before adjustments:

- a. Slacken off the two locking handles (1).
- b. With the machine bed clean place a block of known width or a piece of timber to a set size between fence and near side head cutter.



- c. Rotate the handscrew (2) clockwise to move the spindle towards fence and anti-clockwise to retract it away from the fence.

Adjust the cutter until the knives are just touching the setting piece. Opening/removal of the lid on the near side head hood will facilitate viewing.

By noting the reading on the siko indicator (3) and adding or deducting the difference between the block width and the required cut, a new siko reading may be obtained.

- d. remove the setting piece close/replace hood lid and adjust to new reading.

2) Vertical spindle adjustment.

- a. Release the two spindle barrel locks (4).
- b. Turn handscrew (5) clockwise to raise and anti-clockwise to lower spindle.

Note: Rotation of the handscrew also raises and lowers the drive motor.

- c. When set to the desired height refasten barrel locks (4).

Adjustment to Top and Bottom Through Feed Rolls

For information relating to adjustment maintenance and parts refer to section 'Driven Bed Rolls and Top Through Rolls'.

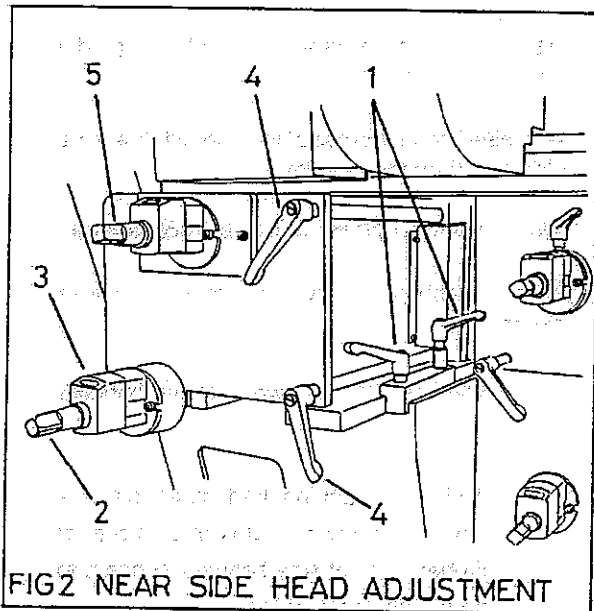



MOUNTING THE CUTTERBLOCKS

General

The XJS machine can be fitted with plain bore or Hydrogrip (hydraulic pressure) cutterblocks. Hydrogrip cutterblocks are used to provide an improved surface finish and allow higher feed speeds to be used. The method of fitting the two types differs.

When changing cutterblocks, be aware that the spindles for plain bore blocks have right or left hand threads, dependent on spindle location, and tighten accordingly.

The spindles are threaded as follows:

Near Side Vertical spindle - left hand thread.

Fence Side Vertical spindle - right hand thread.

The hydrogrip blocks are not screw fitting and require to be pressurised in position on the spindle. To protect the Hydrogrip cutterblock and the machine spindle in the event of hydraulic failure, it is necessary for safety drive collars to be used.

The consequence of not using the safety drive collars will result in the cutterblock seizing on the machine spindle in the event of either; The operator neglecting to pressurise the cutterblock and then running the spindle, or the Hydrogrip cutterblock sleeve losing pressure.

If a seizure occurs, the spindle and cutterblock must be returned to Wadkin for repair. An appropriate charge will be made for this service.

Two types of safety collar are used. These are a threaded safety collar; for use when full length tooling is in use on the machine spindle. A plain safety collar; for use when short length tooling is used on the machine spindle.

To change cutterblocks on Fence and Near Side Heads (Fig 1)

The method of changing cutterblocks depends on the type fitted.

- 1) Isolate power at mains, or at master stop
- 2) Remove covers, guards and extraction ducts as required to allow easy unimpeded access to cutterblock
- 3) Remove cutterblocks as follows taking suitable care when handling:-

Plain Bore Type

- a. Unscrew the cutterblock nut from the spindle with the spanner/s provided. Can be right or left thread (see **General**)
- b. Place the spanner/s on the hexagon of the spindle and the two flat faces of the cutterblock locknut, or;
- c. Hold the spanner (top) securing the spindle firmly in position and unscrew the cutterblock locknut from the spindle with the bottom spanner.

NOTE: DO NOT use any form of percussion tool or damage to spindle bearings can result. DO NOT use a box or extension spanner.

*Hydrogrip Type*

- a. Release locking screw on safety collar (fig 2) and remove from spindle.

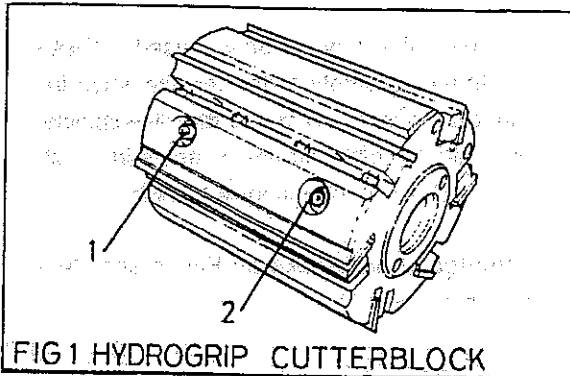

- b. Depressurise the hydrogrip cutterblock by turning the pressure release screw (2), located in a recess on the barrel of the cutterblock one quarter turn to release, using a 3mm A/F hexagon key.
- c. Slide the cutterblock from the spindle. Always leave the pressure release screw (2) undone when the cutterblock is not in use to avoid distortion to the cutterblock due to the variation in room temperatures.
- 4) To replace both types of cutterblock:
- a. Carefully clean spindles, cutterblocks, spacers and collars before fitting new cutterblocks.
- b. Carefully place the cutterblock on the spindle. On the hydrogrip blocks tighten pressure release screw (2), and pressurise the cutterblock by applying hydraulic pressure to the pressure nipple (1) located in a recess located on the barrel of the block (see fig 1).

- c. Fit safety collar (see fig 2) and tighten securing screw.
- d. On plain bore cutterblocks. Tighten the block to the spindle with the spanner/s provided.
- e. Turn the spindle slowly to ensure the cutterblock is free and replace covers, guards, extraction ducts etc.
- f. Operate the spindle for a short period to ensure it rotates freely and without vibration.

CAUTION

Take care not to allow the cutterblock to fall onto the spindle shoulder while fitting. This can cause damage to spindle bearings and subsequent vibration.

Safety Collars (fig 2)

Fitting procedure:

- 1) *Threaded collar*
- a. Mount the cutterblock onto the machine spindle. Make sure the cutterblock fits up to the shoulder on the spindle.
- b. Pressurise cutterblock to the correct working pressure.
- c. Unscrew the pins in the threaded safety collar to the fullest extent, using the knurled heads.
- d. Screw the collar onto the spindle, finger tight, against the end face of the cutterblock.
- e. Reverse the collar on the threads, sufficient to allow the pins to be

brought into line with corresponding holes in the end face of the cutterblock.

- f. When in line, screw the pins into position, locating into the holes of the cutterblock.

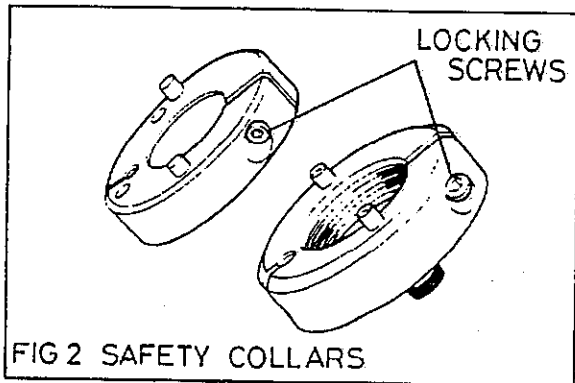

- c. Tighten up the cap screw in the collar, using an Allen Key. This causes the collar to grip the spindle.
- d. The collar will now maintain the drive to the cutterblock in the event of depressurisation.
- e. To release; reverse the procedure.

- g. Tighten the capscrew in the collar, using an Allen Key. This causes the collar to grip the threads on the spindle.
- h. The collar will now maintain the drive to the cutterblock in the event of depressurisation.
- i. To release; reverse the procedure.

2) Plain collar

- a. Mount the cutterblock onto the machine spindle, making sure it fits up to the spindle shoulder. Pressurise cutterblock to the correct working pressure.
- b. Slide the collar with its pins facing the cutterblock along the machine spindle up to the cutterblock. Locate the pins in to the corresponding holes in the block.



MAINTENANCE

Routine Maintenance

Before proceeding with any maintenance ensure power is isolated at mains or at master stop.

Weekly

It is recommended that the machine be cleaned thoroughly once a week, especially when working on hardwood or highly resinous material, to prevent choking of ventilator airways and build-up of deposits on working parts. Ensure sawdust build-up at rear of machine is clear of motors and belts.

Clean all spindles regularly and remove all remains of resin and grease. Do the same with cutterblock collars and machine tables. Check that all machine parts slide, or rotate freely.

Lightly lubricate as directed, do not over lubricate.

If cleaning with compressed air, take care not to direct the jet onto the spindle bearing housings, moving shafts, etc., and avoid forcing dust and debris into bearings and housings.

The Side Head Slideways should be greased weekly using Wadkin grade L6 (see **Approved Lubricants**). Grease nipples for the slideway are located underneath the Near Side Head chipbreaker carrier plate. After lubrication the Heads should be adjusted to their extremes to evenly distribute the grease and prevent sawdust/resin build-up on the slideway.

Three Monthly

Electric drive motors have sealed for life bearings and are maintenance free. However the fan cowls should be removed at intervals and the fans checked for damage,

check for excessive end float, signs of overheating etc. If a cowl itself is damaged it should be replaced. Check tension and condition of drive belts. The belts should be capable of being depressed approximately 1 1/2 to 2cm per metre of span by application of average thumb pressure of 2.2 - 3.2 kgf (5-7 lb) if necessary retension (see Vee Belt Drive Tensioning).

Vee Belt Drive Tensioning (Fig 1)

Both fence and side head motors are mounted in the same way and adjustment to each is similar.

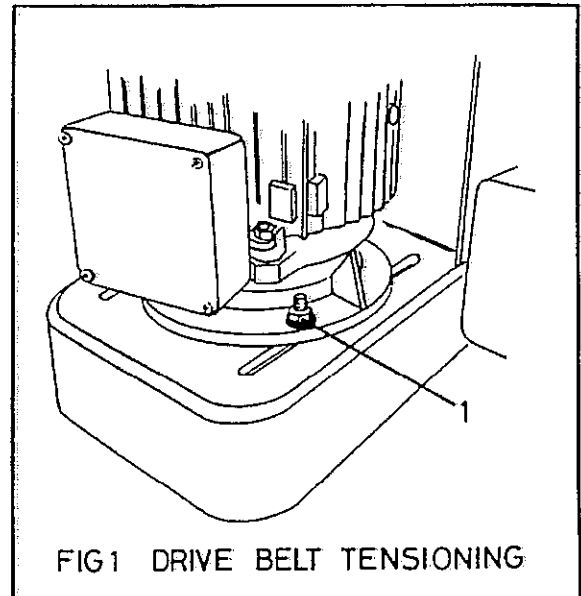

- 1) Slacken off the four motor clamping bolts (1).
- 2) Tension the belts using an outward force on the motor.
- 3) Tighten motor clamping bolts.



Replacing Vee Belts (Fig 1)

Drive belts must be replaced as a set to obtain correct drive performance.

- 1) Relieve tension on the drive belts by slackening off the four bolts (1).
- 2) Slide the motor towards machine until belts may be removed.
- 3) Fit new belts (check size, type and reference).
- 4) Retension and secure bolts.



ILLUSTRATED PARTS LIST

CONTENTS

1. Near Side Head Rise and Fall
2. Near Side Head Lateral Adjustment
3. Near Side Head Spindle and Carriage Locks
4. Fence Side Head Lateral Adjustment
5. Fence Side Head Rise and Fall

IMPORTANT: When ordering spares always quote model and machine number.

CLOSE COUPLED STAGGERED SIDE HEADS

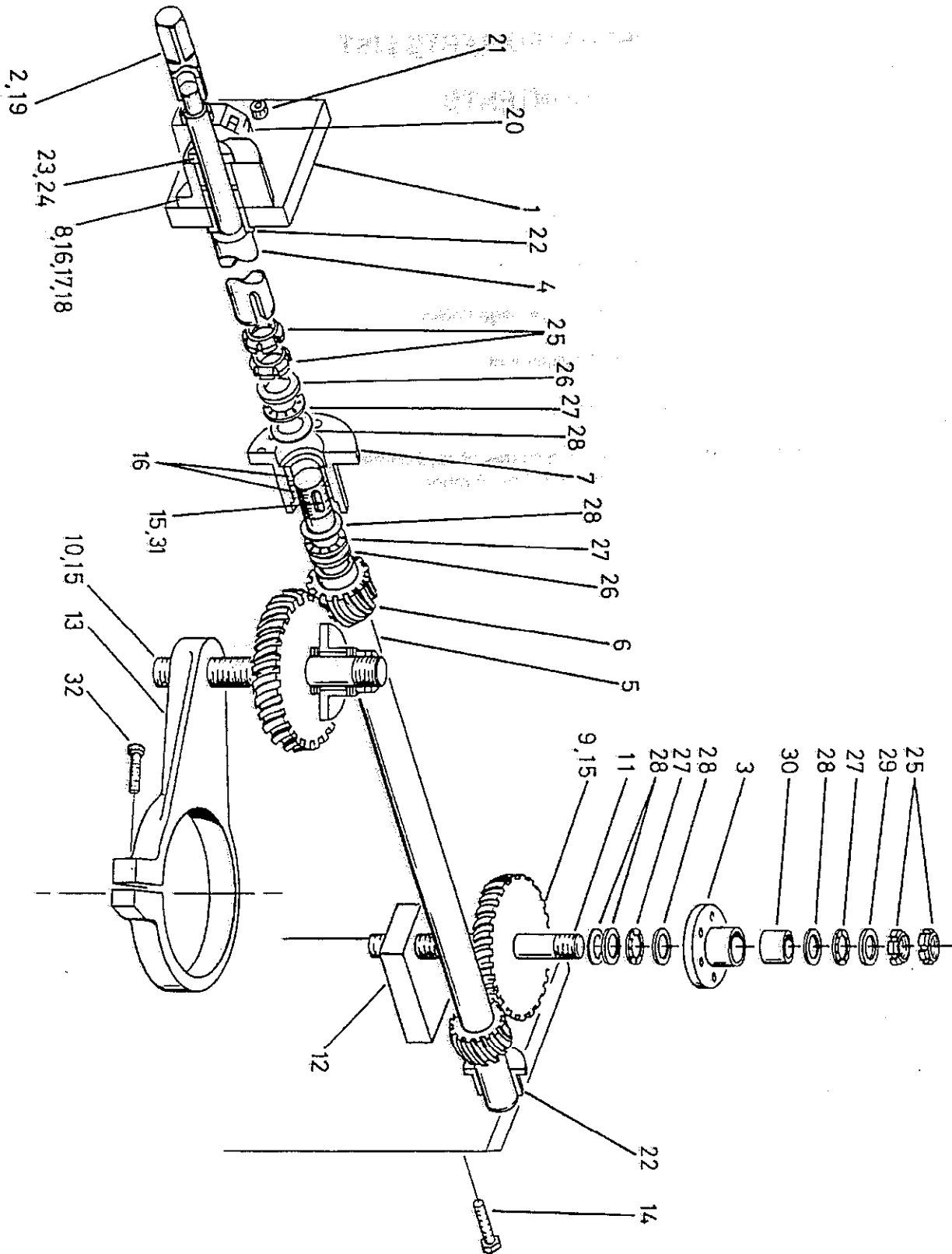

FIG 1 NEAR SIDE HEAD RISE AND FALL



CLOSE COUPLED STAGGERED SIDE HEADS

1. NEAR SIDE HEAD RISE AND FALL

Ref No.	Description	No. Off
1.	Plate for shaft extension	1
2.	Square end shaft extension	1
3.	Housing for vertical shaft bearings	2
4.	Extension shaft	1
5.	Horizontal winding shaft	1
6.	Pinion	2
7.	Housing for horizontal shaft bearings	1
8.	Bracket for shaft bearing	1
9.	Gear	2
10.	Rise and fall leadscrew (left hand thread)	1
11.	Rise and fall leadscrew (right hand thread)	1
12.	Screw block for motor slide	1
13.	Adjusting screw clamp for spindle barrel	1
14.	Hexagon head setscrew M12 x 45mm long	2
15.	Key 6mm x 6mm x 20mm long	3
16.	Bronze bush 25mm O/D x 20mm I/D x 15mm long	4
17.	Hexagon socket capscrew M8 x 16mm long	2
18.	Plain washer M8	2
19.	Taper pin No.1	1
20.	'SIKO' digital indicator 0902E 4mm	1
21.	Hexagon socket capscrew M8 x 25mm long	2
22.	Bronze headed bush 26mm O/D x 20mm I/D x 15mm long	2
23.	Locking collar	1
24.	Hexagon socket grubscrew M6 x 6mm long	1
25.	Notch nut M20 x 1.5mm	6
26.	Shaft washer 'INA' WS81104	4
27.	Thrust bearing 'INA' AXK 2035	6
28.	Thrust washer 'INA' AS 2035	8
29.	Thrust washer 'INA' WS 81104	2
30.	Bronze bush 25mm O/D x 20mm I/D x 20mm long	2
31.	Hexagon socket capscrew M4 x 12mm long	1
32.	Hexagon head setscrew M10 x 55mm long	1

NOTE: Both leadscrew assemblies are identical apart from the 'Handed' Leadscrews

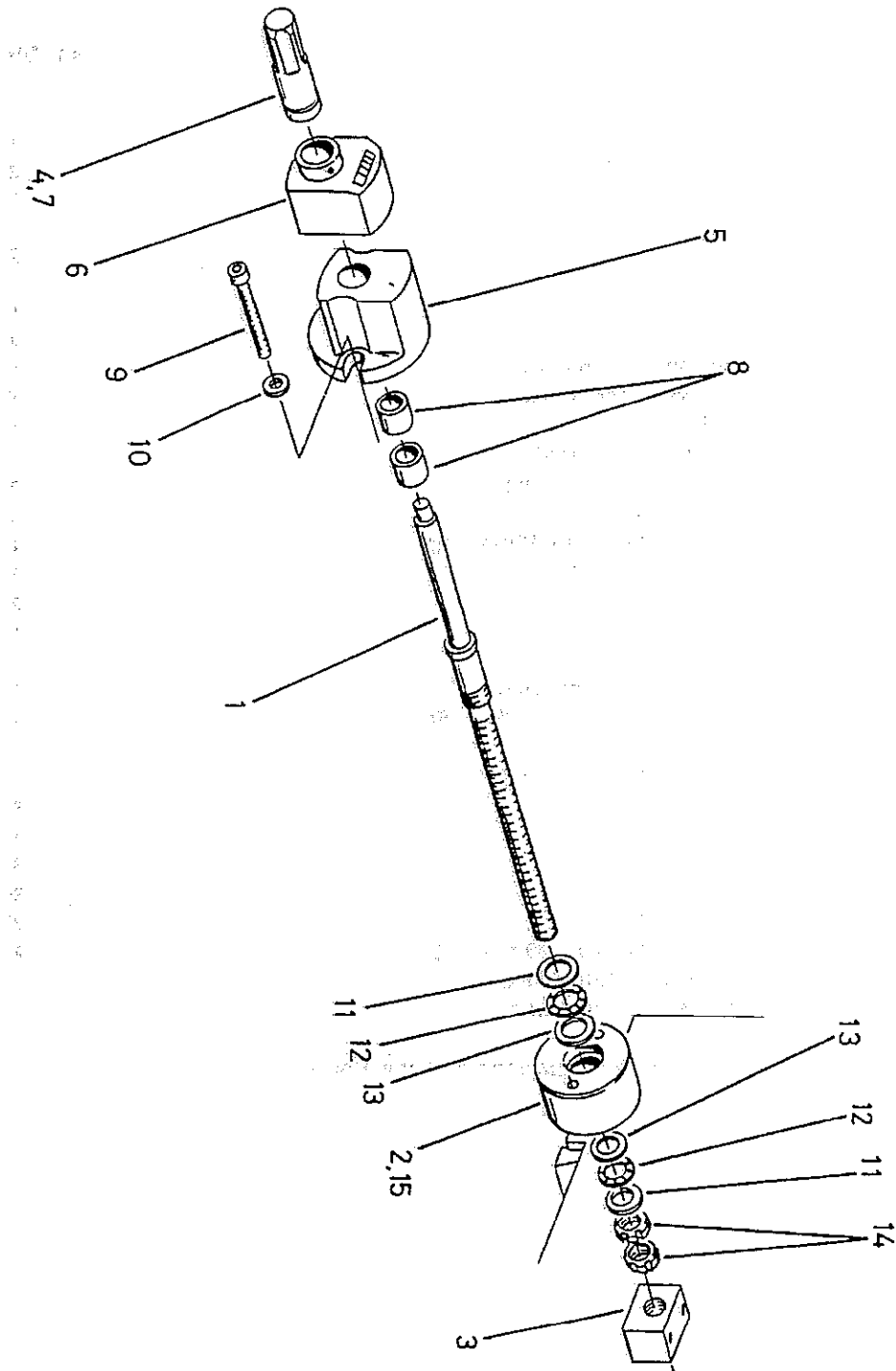

FIG 2 NEAR SIDE HEAD LATERAL ADJUSTMENT



2. NEAR SIDE HEAD LATERAL ADJUSTMENT

Ref No.	Description	No Off.
1.	Screw for cross traverse	1
2.	Housing for traverse screw bearings	1
3.	Nut traverse	1
4.	Shaft extension	1
5.	Bracket for shaft bearings	1
6.	'SIKO' digital indicator 0902 1.2mm	1
7.	Taper pin No.1	1
8.	Bronze bush 25mm O/D x 20mm I/D x 15mm long	2
9.	Hexagon socket capscrew M8 x 60mm long	2
10.	Plain washer M8	2
11.	Thrust washer 'INA' LS 2542	2
12.	Thrust bearing 'INA' AXK 2542	2
13.	Thrust washer 'INA' AS 2542	2
14.	Notch nut M24 x 1.5mm P.	2
15.	Bronze bush 30mm O/D x 25mm I/D x 20mm long	1

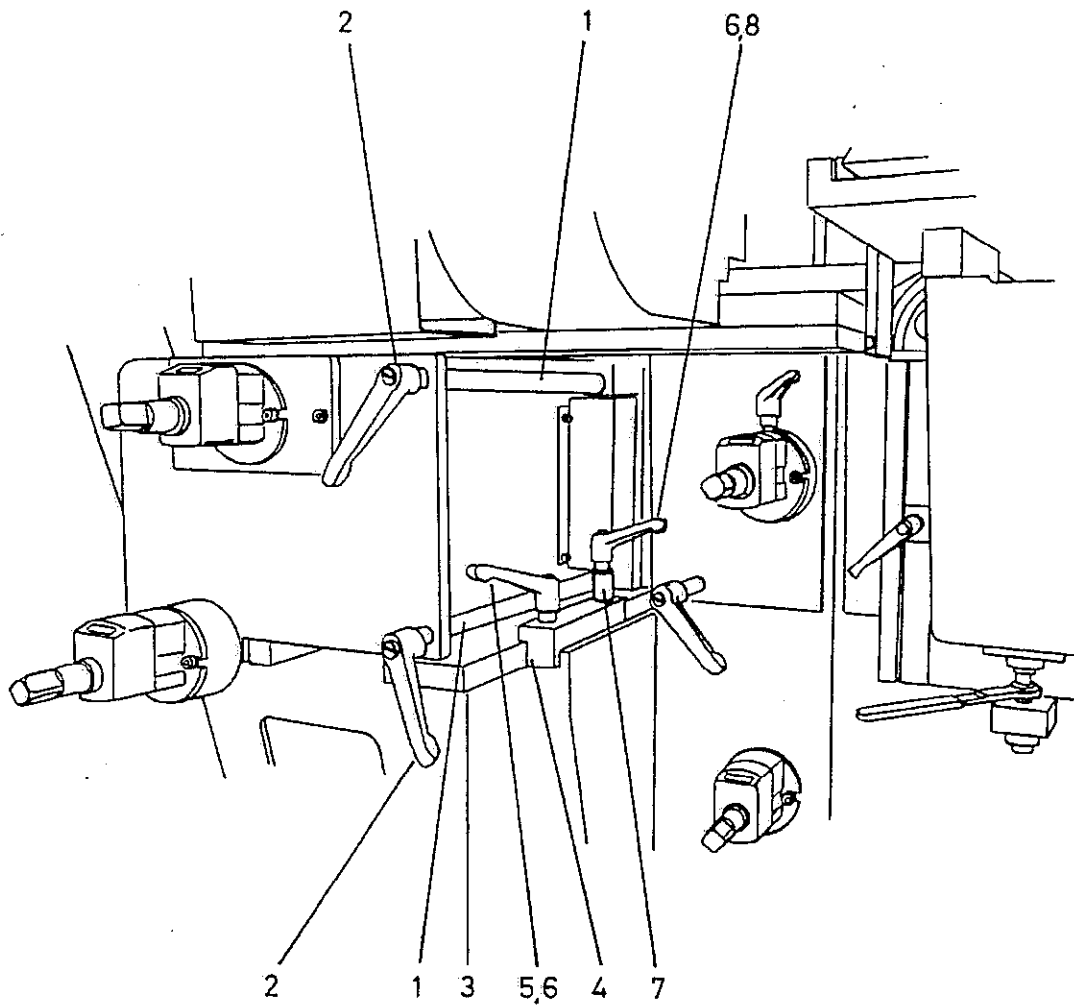

FIG 3 NEAR SIDE HEAD SPINDLE AND CARRIAGE LOCKS



CLOSE COUPLED STAGGERED SIDE HEADS

3. NEAR SIDE HEAD SPINDLE AND CARRIAGE LOCKS

Ref No.	Description	No Off.
1.	Shaft for side head lock	2
2.	Handle (male) M12 x 25mm	2
3.	Slide plate	1
4.	Lock bar	1
5.	Stud M12 x 70mm long	2
6.	Kipp handle (female) M12	2
7.	Spacing collar 25mm O/D x 14mm I/D x 50mm long	1
8.	Stud M12 x 125mm long	1

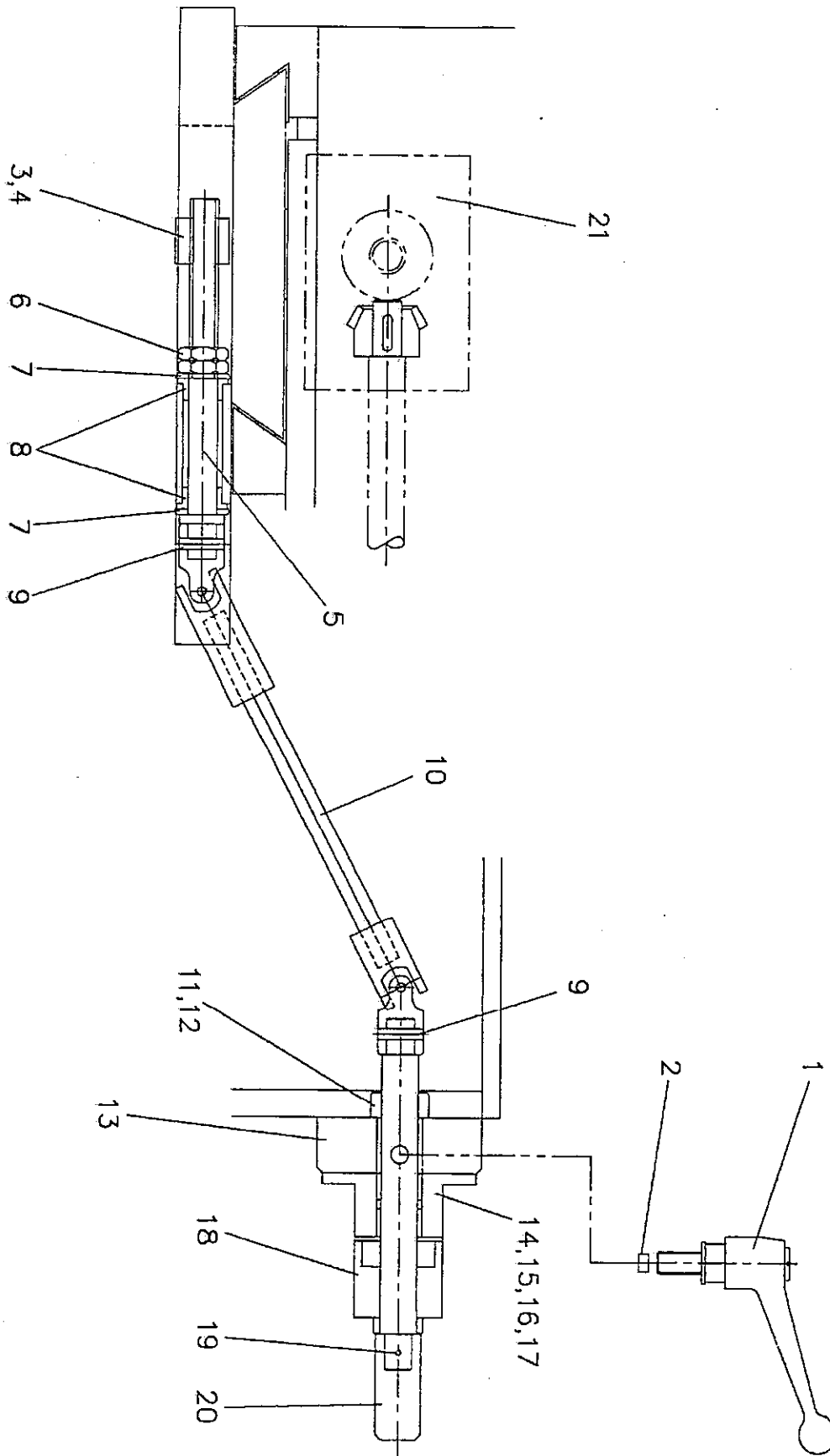

FIG 4 FENCE SIDE HEAD LATERAL ADJUSTMENT



4. FENCE SIDE HEAD LATERAL ADJUSTMENT

Ref No.	Description	No Off.
1.	Locking handle	1
2.	Brass pad	1
3.	Traverse nut	1
4.	Hexagon socket capscrew M8 x 35mm long.	2
5.	Traverse screw	1
6.	Nut M16	2
7.	Washer M16	2
8.	Flanged bush 16mm I/D x 22mm O/D x 12mm long.	2
9.	Tension pin dia. 6mm x 24mm long.	2
10.	Universal coupling shaft	1
11.	Collar	1
12.	Hexagon socket grubscrew M6 x 6mm long.	1
13.	Spacer	1
14.	Housing	1
15.	Bush 20mm I/D x 25mm O/D x 15mm long.	2
16.	Hexagon socket capscrew M8 x 50mm long	2
17.	Washer M8	2
18.	'SIKO' indicator - 0902E 2mm	1
19.	Taper pin No.1	1
20.	Square end	1
21.	Rise and fall gearbox (Shown for reference)	1

CLOSE COUPLED STAGGERED SIDE HEADS

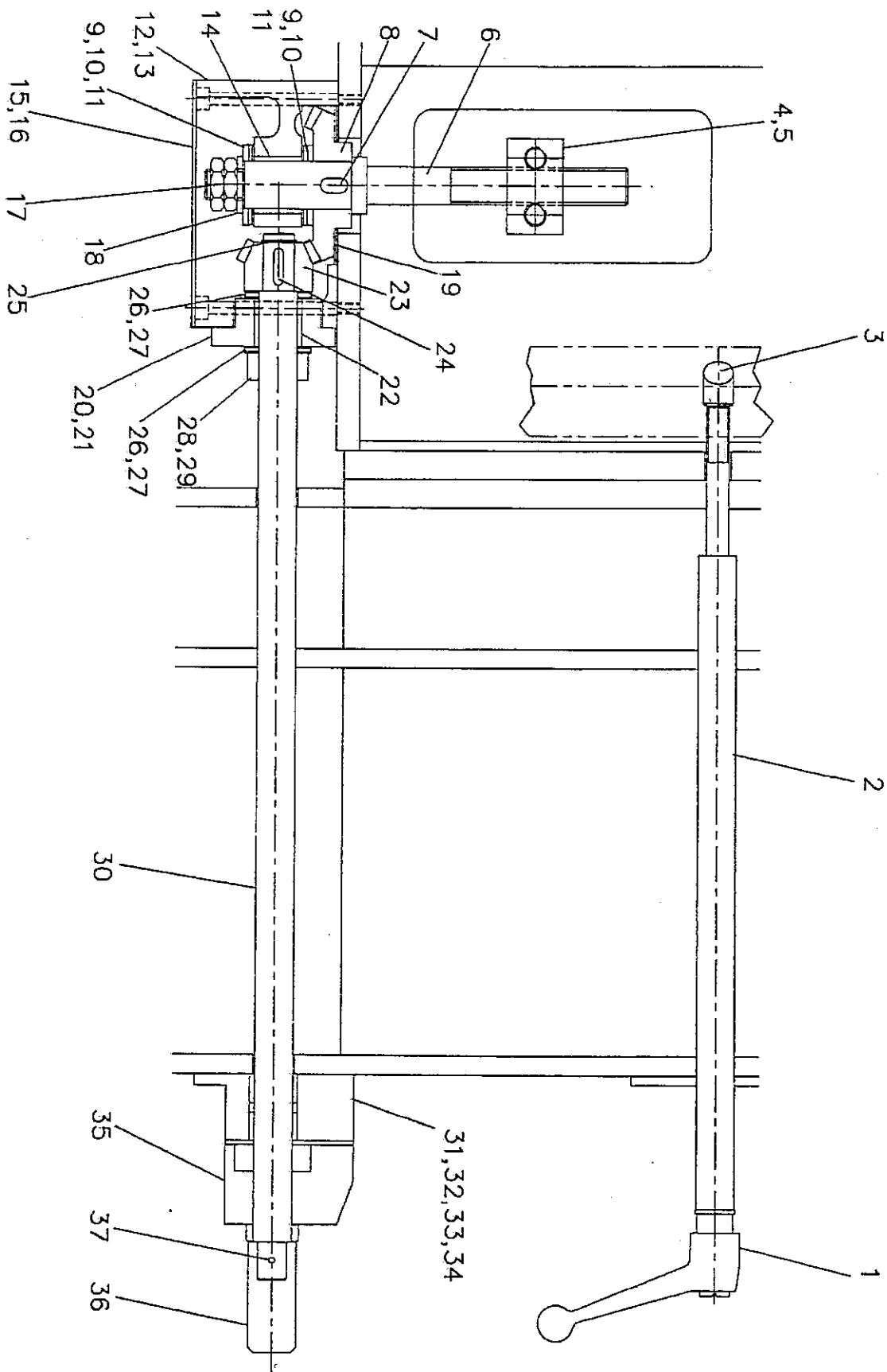

FIG 5 FENCE SIDE HEAD RISE AND FALL



CLOSE COUPLED STAGGERED SIDE HEADS

5. FENCE SIDE HEAD RISE AND FALL

Ref No.	Description	No Off.
1.	Locking handle	1
2.	Locking shaft	1
3.	Clamping pad	1
4.	Rise and fall nut	1
5.	Hexagon socket capscrew M12 x 35mm long	2
6.	Rise and fall screw	1
7.	Key 8mm x 7mm x 14mm long	1
8.	Bevel gear 32 teeth	1
9.	'INA' Thrust bearing AXK 2542	2
10.	'INA' Thrust washer AS 2542	2
11.	'INA' Thrust washer WS 81105	2
12.	Bevel gear box	1
13.	Hexagon socket capscrew M6 x 75mm long	4
14.	Bush 25mm I/D x 30mm O/D x 25mm long	1
15.	Cover	1
16.	Pan head screw M4 x 10mm long	3
17.	Locknut M16	2
18.	Washer M16	1
19.	Sealing ring	1
20.	End cap	1
21.	Hexagon socket capscrew M6 x 20mm long	3
22.	Bush 20mm I/D x 25mm O/D x 25mm long	1
23.	Bevel gear 16 teeth	1
24.	Key 5mm x 5mm x 20mm long	1
25.	Circlip - 16mm dia. external	1
26.	'INA' Thrust bearing AXK 2035	2
27.	'INA' Thrust washer AS 2035	4
28.	Collar	1
29.	Hexagon socket grubscrew M6 x 6mm long	1
30.	Shaft	1
31.	Housing	1
32.	Bush 20mm I/D x 25mm O/D x 15mm long	2
33.	Hexagon socket capscrew M8 x 20mm long	2
34.	Washer M8	2
35.	'SIKO' indicator 0902 2mm	1
36.	Square end	1
37.	Taper pin No.1	1

SECTION 9 TOP HEAD MODULE

General (Fig 1)

The Top head cutterblock carrier has attached to it, a bank of three individual chipbreakers prior to the spindle and a pad pressure following the spindle.

An opposed top roller/bottom roller combination, driven at the rear of the module by 'Siti' gearboxes, trails the cutterblock.

A small amount of adjustment is catered for on the horizontal heads.

Note: The machine is factory set to give 12mm movement backwards from the datum face of the fence when it is set at zero.

If it should be necessary to obtain further lateral movement when at the maximum rearward position, it may be obtained by removing the pulley guard and releasing the belt tension. (Refer to Maintenance - Vee Belt Drive Tensioning). Move the belts onto the next vacant pulley groove to bring them back into line and then re-tension the belts.

Locking collars prevent the spindle movement exceeding the original factory set boundaries and therefore if the belts are repositioned, then the rear stop (1) must also be reset.

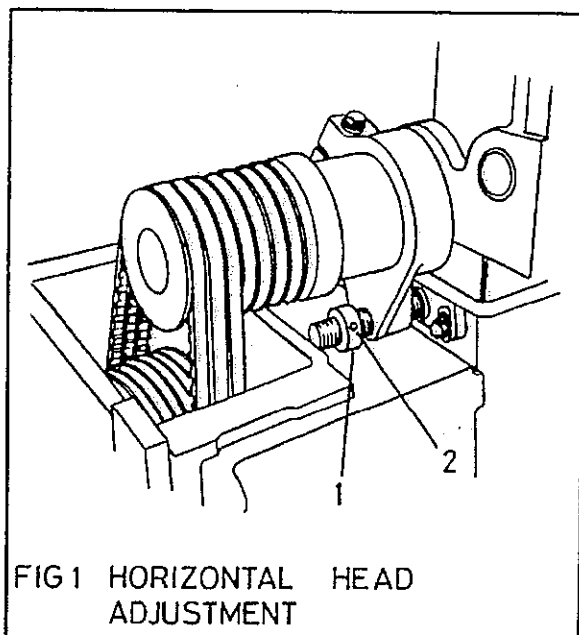

This may be done by slackening off the grub screw (2), moving the collar back a further 12mm and then retightening the grub screw (2).

Top Head Vertical and Horizontal Adjustment (Fig 2, Fig 3)

Before making any horizontal adjustment ensure that the jointer is 'parked' clear (see **Jointer** chapter).

Horizontal Adjustment

- 1) Isolate power at master stop or mains.
- 2) Release the spindle barrel lock (2).
- 3) Adjust using the handscrew (1).
- 4) Tighten barrel lock (2).

Manual Vertical Adjustment - Top Head Only.

Note: The outboard bearing support is hydraulically locked into position and **MUST** be released before any vertical adjustment is made. The lock and unlock control buttons are found on the main control cabinet and on the infeed and outfeed sub control unit (6) depending on modular assembly.

- 1) Release hydraulic locks (7) by pressing button indicated thus . Then isolate power supply at master stop or at mains.
- 2) Ensure bed is clean.
- 3) Remove jointer cover (3) by slackening off thumb screws (4) or remove blanking cover if no jointers are fitted. This allows easy access to cutter.

TOP HEAD MODULE

- 4) Place a datum block (5) of known thickness under the cutterblock.

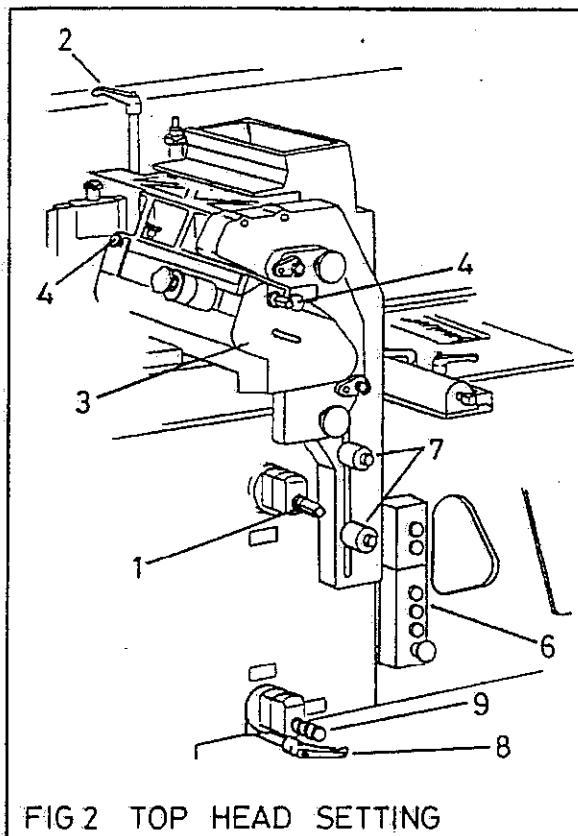

FIG 2 TOP HEAD SETTING

- 5) Rotate the hand screw (9) clockwise to lower the spindle or anti-clockwise to raise the spindle. The knives should just touch the block when the spindle is rotated slowly by hand via the outboard bearing.

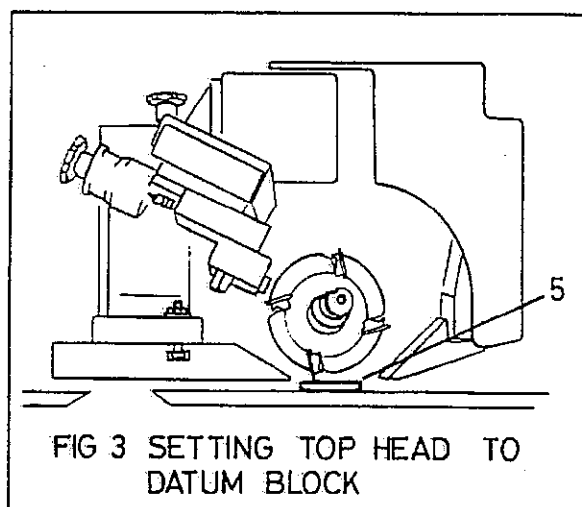

FIG 3 SETTING TOP HEAD TO DATUM BLOCK

- 6) When setting to a datum block check the digital readout. If necessary reset counter by loosening grub screw in collar of the readout and then turning collar until the reading coincides to the thickness of the datum block. When set remove block.
- 7) Set head to desired position and replace cover (3).
- 8) Switch power on and engage hydraulic locks by pressing button indicated $\rightarrow*$.

Electrical Vertical Adjustment - Top Head and Beam

Note: The powered vertical adjustment of the beam is electrically interlocked with the Top head and cannot move until the hydraulic locks are disengaged.

- 1) Release outboard bearing support locks by pressing button marked thus $\rightarrow|+$. The lock and unlock buttons are found on the main control cabinet or on the infeed sub control station.
- 2) Engage clutch lever (8). If the clutch does not readily engage, turn the handscrew (9), slightly to the left or right until it engages.
- 3) To raise the head/beam press the button marked ' \uparrow '. The button with the downward pointing arrow moves the head/beam down. These buttons again are found on the main control cabinet or on the infeed sub station.
- 4) When in the required position re-engage locks by pressing button marked $\rightarrow*$. Disengage clutch.

Top Head Chipbreaker and Pad Pressure (Fig 4)

Ensure power is isolated from machine. The bed should be clean and the cutterblock already 'set up'. Place a straight edge on the table under the pad pressure, cutterblock and chipbreakers. When set all three should be in line with each other.

To Adjust Pad Pressure

- 1) Use adjusting screw (1) to raise and lower pad.

- 2) Slacken off pad pressure locking nuts (2) and laterally position the pad nose 5mm clear of the maximum cutting circle. Also position pad, width wise, to suit timber.
- 3) Retighten nuts (2).

To Adjust Chipbreaker

The chipbreaker is made up of a bank of three individual units each positioned in a similar way.

Set the height of each unit as follows.

- 4) Slacken off the two locknuts (3).
- 5) Raise/lower the chipbreaker unit until the nose touches the straight edge placed under the pad pressure after the top head.
- 6) Tighten the locknuts (3).
- 7) A stop screw (4) provides for small adjustment to align all the chipbreaker nose pieces.

Lateral adjustment

- 8) Slacken off the two locknuts (5) at the rear of the top head and turn the adjusting screw (6) until the chipbreaker nose is approximately 20mm from the cutter knives.
- 9) Fasten rear locknuts (5).

Adjustment to Top and Bottom Through Feed Rollers

For information relating to adjustment, maintenance and parts refer to chapter - Driven Bed and Top Through Feed Rolls.

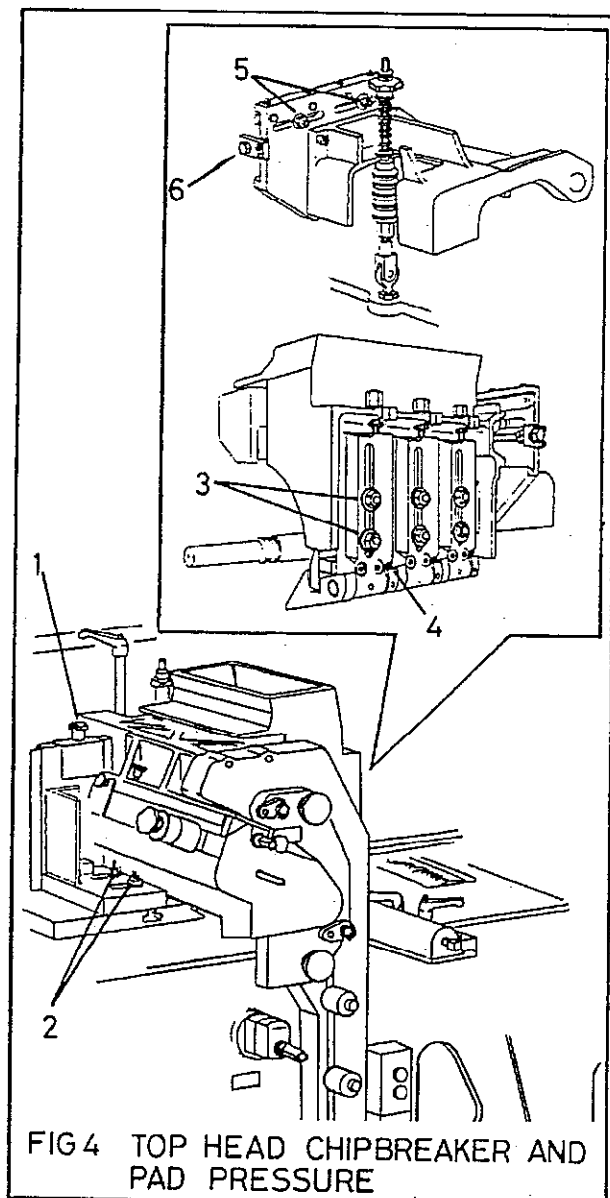

FIG 4 TOP HEAD CHIPBREAKER AND PAD PRESSURE



MOUNTING THE CUTTERBLOCKS

General

The XJS machine can be fitted with plain bore or Hydrogrip (hydraulic pressure) cutterblocks. Hydrogrip cutterblocks are used to provide an improved surface finish and allow higher feed speeds to be used. The method of fitting the two types differs.

When changing cutterblocks, be aware that the spindles for plain bore blocks have right or left hand threads, dependent on spindle location, and tighten accordingly.

The top horizontal spindle has a right hand thread.

The Hydrogrip blocks are not screw fitting and require to be pressurised in position on the spindle. To protect the Hydrogrip cutterblock and the machine spindle in the event of hydraulic failure, it is necessary for safety drive collars to be used.

The consequence of not using the safety drive collars will result in the cutterblock seizing on the machine spindle in the event of either; the operator neglecting to pressurise the cutterblock and then running the spindle, or the Hydrogrip cutterblock sleeve losing pressure.

If a seizure occurs, the spindle and cutterblock must be returned to Wadkin for repair. An appropriate charge will be made for this service.

Two types of safety collar are used. These are a threaded safety collar; for use when full length tooling is in use on the machine spindle. A plain safety collar; for use when short length tooling is used on the machine spindle.

Outboard bearings are fitted to the horizontal spindles to give greater rigidity to the cutterblock; these support each spindle at its outer position.

The outboard bearing support bracket on the Top heads is hydraulically locked from the control panel or infeed station and is interlocked to the powered rise and fall of the spindle to ensure the plate is free to move with the spindle. The bearing plate locks must be released before making adjustments and once released the power can be isolated before commencing to change/alter cutterblocks.

To Change Cutterblock (Fig 1, Fig 2, Fig 3)

The method of changing tooling depends on the type fitted and it will be first necessary to remove any outboard bearing, locking collar, spindle nut and spacers fitted, as applicable. Isolate machine from power source.

- 1) Slacken off shoulder screws (1) and remove outboard bearing cover (2). If jointers are fitted the cover and position of shoulder screws may vary to those illustrated.
- 2) Depressurise the outboard bearing by turning the pressure release valve (6) one quarter of a turn using a 3mm Allen key.
- 3) Ensure pad pressure, chipbreaker and jointer are all well clear of cutterblock especially if fitting a larger cutting circle.



- 4) Slacken off the two 12mm collar nuts (3), swing captive 'C' washers (4) clear and remove outboard bearing housing (5).

Note: This housing is spigoted and must be pulled horizontally.

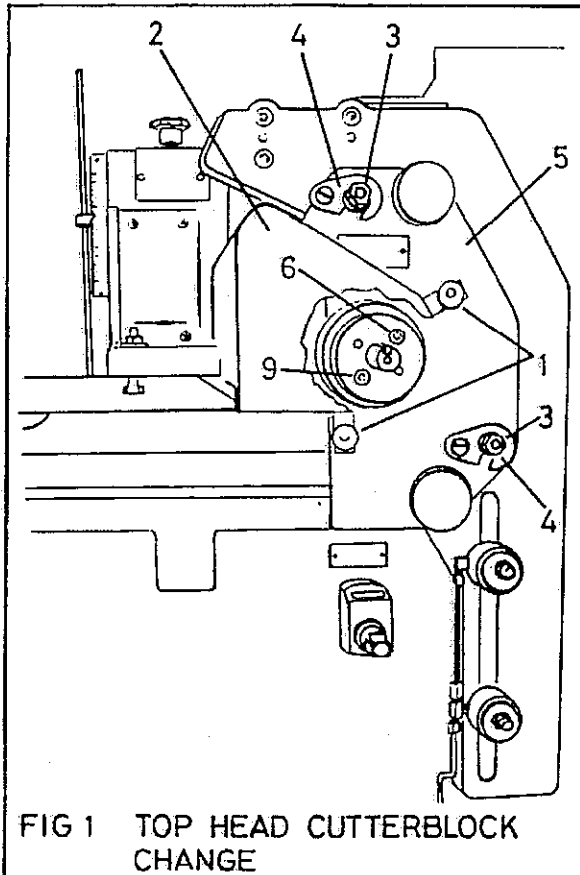

FIG 1 TOP HEAD CUTTERBLOCK CHANGE

- 5) Remove cutterblock off spindle. When handling cutterblocks care should be taken to avoid injury on knife blades. The method of removal of the cutterblocks varies depending on the block type.

a) Plain Bore Cutterblock

Unscrew the cutterblock nut from the spindle with the spanner/s provided. Can be right or left-hand thread (see General).

Place the spanner/s on the hexagon of the spindle and the two flat faces of the cutterblock locknut, or;

Hold the spanner (top) securing the spindle firmly in position and unscrew the cutterblock locknut from the spindle with the bottom spanner.

Note: DO NOT use any form of percussion tool or damage to the spindle bearings can result. DO NOT use a box or extension spanner.

Remove cutterblock.

b) Hydrogrip Cutterblock with Plain Collar.

Release the capscrew in the collar using an Allen key. This causes the collar to loosen its grip on the spindle and slide off.

Note: On reassembly ensure this collar is fitted with locating pins facing cutterblock.

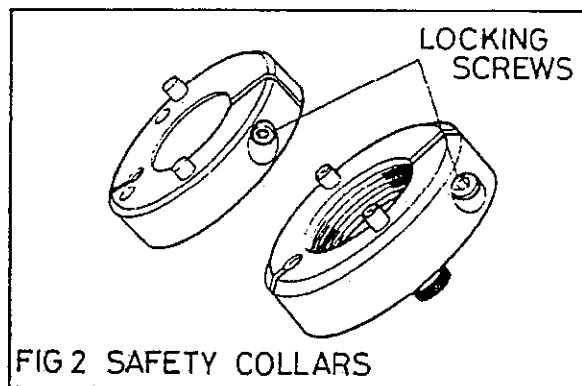
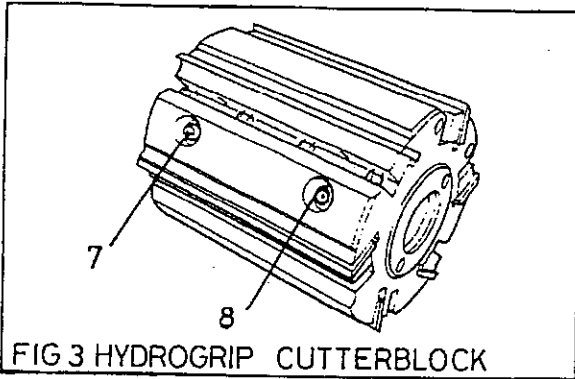

FIG 2 SAFETY COLLARS

Depressurise the hydrogrip cutterblock by turning the pressure release screw (8), located in a recess on the barrel of the cutterblock one quarter turn to release, using a 3mm A/F hexagon key.

Slide the cutterblock from the spindle.



Always leave the pressure release screw (8) undone when the cutterblock is not in use to avoid distortion to the cutterblock due to the variation in room temperatures.

c) Hydrogrip Cutterblock with Threaded Collar

Release the capscrew in the collar using an Allen key. Unscrew the two knurled headed pins until the collar itself is free to unscrew.

Note: On reassembly this collar must be screwed finger tight against the pressurised block and then, if needed, unscrewed until the pins line up with the corresponding cutterblock holes.

Depressurise the hydrogrip cutterblock by turning the pressure release screw (8), located in a recess on the barrel of the cutterblock one quarter turn to release, using a 3mm A/F hexagon key.

Slide the cutterblock from the spindle.

Always leave the pressure release screw (8) undone when the cutterblock is not in use to

avoid distortion to the cutterblock due to the variation in room temperatures.

6) Before replacing cutterblock ensure spindle, spindle shoulder, shoulder of cutterblock and bores are all clean.

7) Carefully place the cutterblock on the spindle. On the hydrogrip blocks tighten pressure release screw (8), and pressurise the cutterblock by applying hydraulic pressure to the pressure nipple (7) located in a recess located on the barrel of the block (see Fig 3).

8) Fit safety collars and/or spacers as applicable. On the plain bore cutterblocks, tighten the block to the spindle with the spanner/s provided.

9) Replace bearing housing (5) and retighten captive 'C' washer (4) and collar nuts (3). Tighten pressure release valve (6) and pressurise bearing to 300 bar (4350 p.s.i.) by application of hydraulic pressure to the nipple (9) in the recess on the face of the bearing.

10) Rotate spindle slowly by hand to check knives are clear of chipbreaker, pad pressure etc. Replace outboard bearing cover, engage power and start head for a short period of time to ensure cutterblock is running smoothly and without vibration.

MAINTENANCE

Routine Maintenance

Caution: Before maintenance is performed on the machine the power must be switched off at master stop or mains.

Weekly

It is recommended that the machine be cleaned thoroughly once a week, especially when working on hardwood or highly resinous material, to prevent choking of ventilator airways and build-up of deposits on working parts.

Clean all spindles regularly and remove all remains of resin and grease. Do the same with cutterblock collars and machine tables. Check that all machine parts slide, or rotate freely. Lightly lubricate as directed, do not over-lubricate.

If cleaning with compressed air, take care not to direct the jet onto the spindle bearing housings, moving shafts etc., and avoid forcing dust and debris into bearings and housings.

Centralised lubrication points at the front of the machine allows for oiling of the top head slideway as part of an overall oiling operation.

The slideways should be oiled at weekly intervals. Once lubricated the head should be traversed to its maximum and minimum position to ensure even distribution of oil and to prevent sawdust/resin 'build up' on slideways. 'Wadkin' grade L4 oil should be used (see **Approved Lubricants**).

Three Monthly (Fig 1)

Electric drive motors have sealed for life bearings and are maintenance free.

However the fan cowl should be removed at intervals and the fan checked for damage, check for excessive end float, signs of overheating etc. If the cowl itself is damaged it should be replaced.

At the rear of the module remove the cover over the top head spindle pulley. Clean and grease using Wadkin L6 grease (see **Approved Lubricants**) the spindle barrel lateral adjustment screw (1).

NB see page 10-10

Whilst the cover is off also check tension and condition of drive belts. The belts (2) should be capable of being depressed approximately 1 1/2 to 2cm per metre of span by application of average thumb pressure of 2.2 - 3.2 kgf (5-7 lbf). If necessary retension (see **Vee Belt Drive Tensioning**).

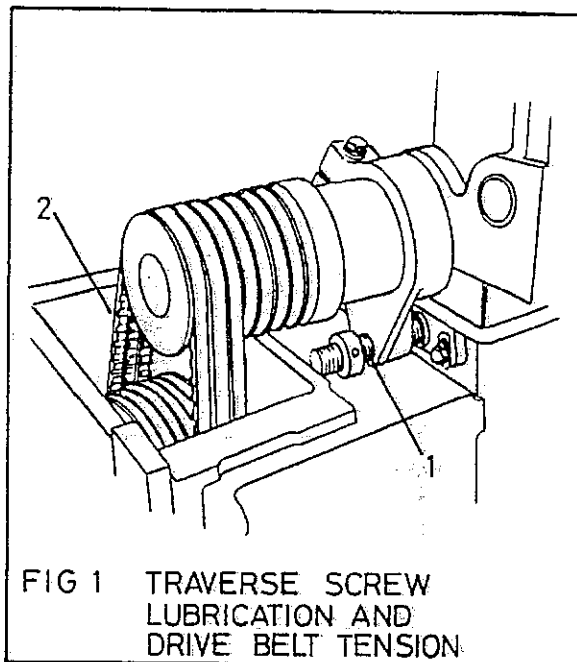

FIG 1 TRAVERSE SCREW
LUBRICATION AND
DRIVE BELT TENSION

Vee Belt Drive Tensioning (Fig 2)

It is important that drive belts are correctly set as insufficient tension causes slipping and premature belt wear.

Too much tension causes bearing wear. The method of adjustment is as follows:

- 1) Isolate power at master stop or mains.
- 2) Remove cover to expose spindle pulley and belts (Fig 1).
- 3) Slacken off motor mounting plate bolts (1).
- 4) Tension belt by slackening the top locknut (2) and turning the bottom locknut (3) in an anticlockwise direction.

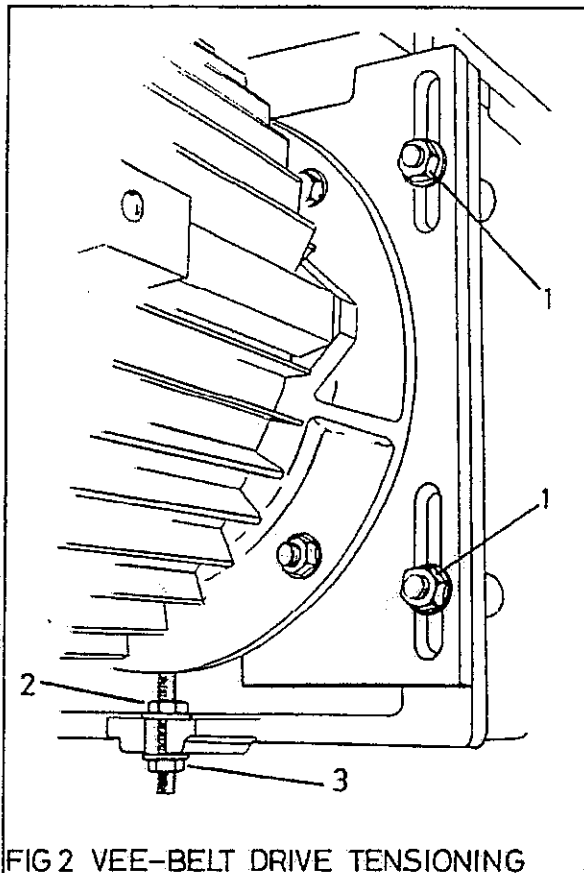

- 5) When tensioned lock up both nuts (2 and 3) and motor mounting bolts (1). Refit cover and engage power.

There may be occasions where the tensioning arrangement does not follow that described. However, all belt drive adjustment follows the same general principle: This involves moving the drive pulley centres or motor platform, thus taking up any slack in the belt drive. The method used will normally be self evident. Always retighten any securing features fitted.

If one or more of the vee-belts becomes faulty it will usually be necessary to replace as a complete set (see Replacing Drive Belts). It is impossible to obtain a correctly tensioned drive, with all belts taking an equal share of the load, by mixing old and new, or different belts.

Replacing Drive Belts

Drive belts must be replaced as a set to obtain correct drive performance.

- 1) Isolate power at master stop or mains.
- 2) Remove cover.
- 3) Relieve tension on belts by reducing drive centres i.e. slacken off the four motor mounting bolts (1), the locknut (3) and raise the motor by rotating nut (2) in a clockwise direction.
- 4) Remove old drive belts and fit a new set of belts of the same size, type and reference (see Motor and Drive Belt Data).
- 5) Retension the new belt set (see Vee Belt Tensioning).

Note: It may at times be necessary to remove a drive pulley. The motor shaft pulleys are fitted with taper lock bushes (see fig 3). Spindle pulleys are located on tolerance rings and held on by spigot washer and screw.

Removal and Refit of Drive Pulleys (Fig 3)

To remove a Taper-Lock Bush Pulley:

- 1) Slacken off all screws (1) several turns using a hexagonal key. Remove one or two screws according to number of jacking holes (2).
- 2) Insert screws in jacking holes after oiling thread and point of grub screws, or thread and head of capscrews, as applicable.
- 3) Tighten screws (1) alternatively until bush (3) is loosened in pulley hub and assembly is free on shaft.
- 4) Remove pulley assembly from shaft.

To Refit a Taper-Lock Bush Pulley:

- 1) Ensure that mating taper surfaces are completely clean and free from oil or dirt. Insert bush in hub and line up screw holes.
- 2) Oil thread and point of grub screws, or thread and head of capscrews. Place screws (1) loosely in threaded holes in hub of pulley.
- 3) Clean shaft, fit hub and bush to the shaft as a unit. Locate in position. On fitting; the bush will nip the shaft first, then hub will be drawn onto bush.

Note: It is necessary to axially align drive and driven pulleys.

- 4) Using a hexagonal key, alternatively tighten screws (1), until all screws are pulled up securely. Use a short length of pipe on key to increase leverage.
- 5) After the drive has been running under load for a short time, stop and check tightness of screws. Tighten if needed.

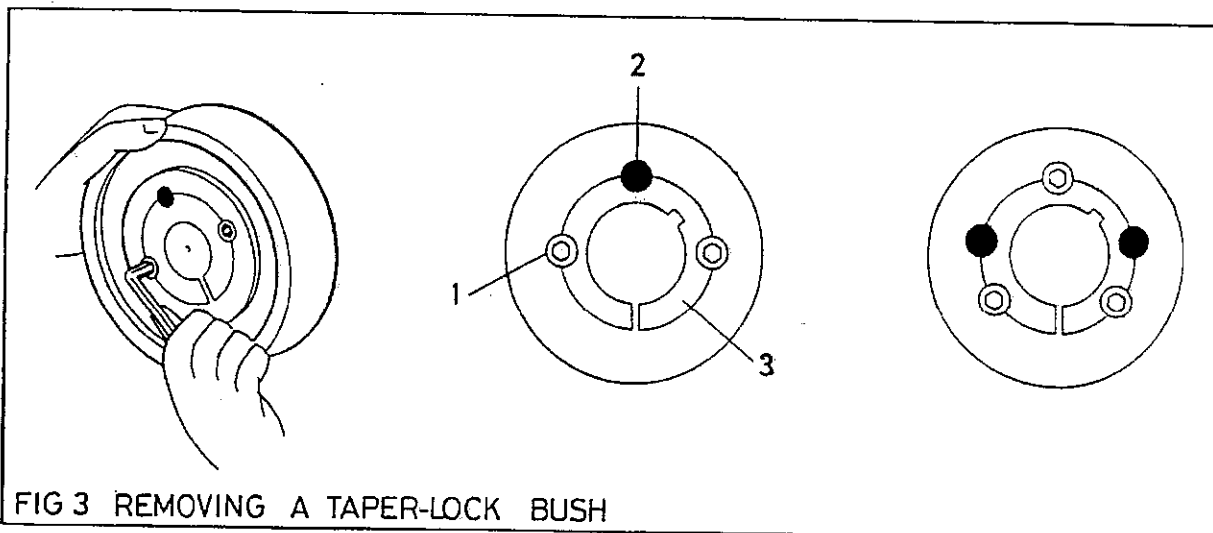

FIG 3 REMOVING A TAPER-LOCK BUSH



- 6) Fill all empty screw holes with grease to exclude dirt.

Preparation prior to fitting bearings

Wadkin strongly recommend buying an exchange spindle rather than attempting a bearing change.

Before fitting a new bearing, the protection lubricant must be meticulously removed with petroleum spirit, triethylamine, or other volatile solvent.

In order to prevent the moving parts from being damaged by drying out due to over cleaning, add a small amount of the bearing lubricant to the cleaning agent at the second bath.

The film of grease which remains after the solvent has evaporated will provide protection for the bearing until charged with lubricant.

The new bearings should be charged with

'Kluber' lubricant, type 'Isoflex' NBU 15. It is important that the correct amount of grease is applied, preferably using the formula:

$$G \text{ (weight in grams)} = d \times B \times 1.01$$

d = bore of bearing in mm

B = width in mm

This is approximately sufficient to fill one third of the bearing volume.

Outboard Bearing Change Top Head (Fig 4)

Note: Work must take place in a clean and dry environment, failure to do so could result in premature bearing failure. Isolate power at mains or at master stop before proceeding.

- 1) Remove outboard bearing assembly from machine (see **Changing Cutterblock**).

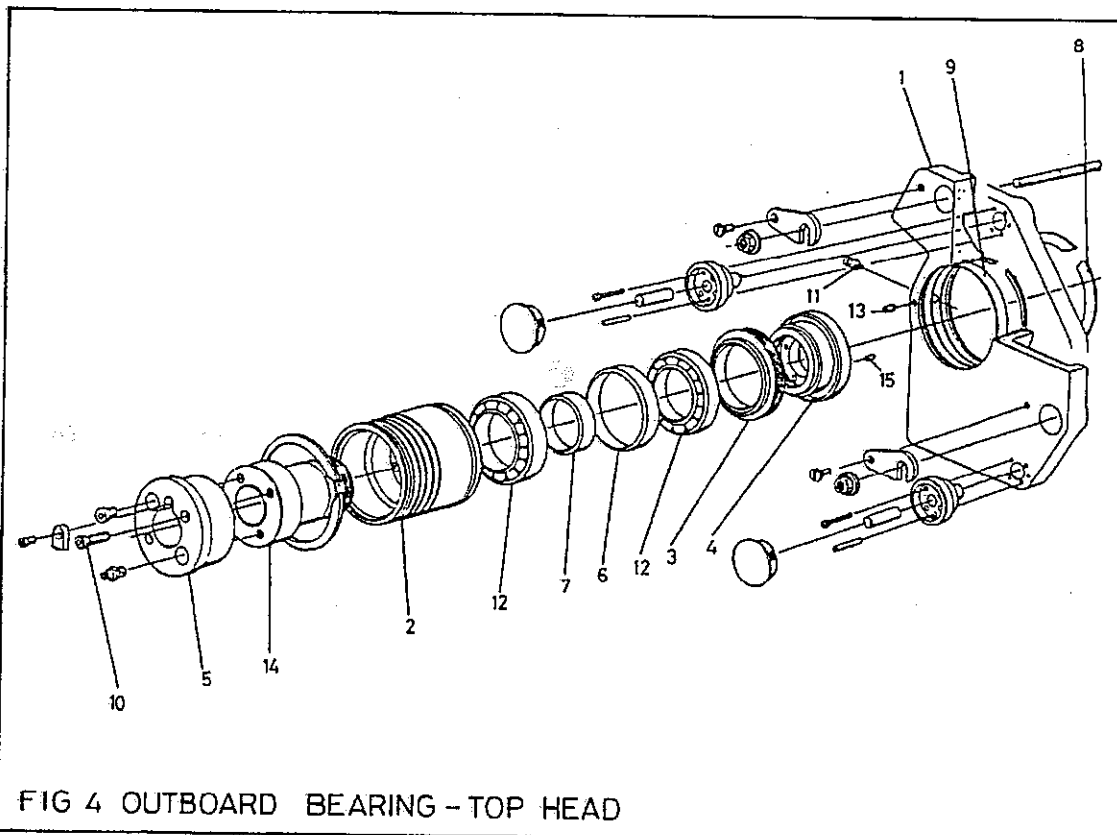

FIG 4 OUTBOARD BEARING - TOP HEAD



Note: It is not necessary to remove the housing assembly (2) from the mounting place (1), unless the housing (2) has become damaged. To remove see later note 'Housing Removal'.

2) Remove 2 off grubscrew (15). Remove ETP sleeve locknut (4), remove 2 off hexagon socket capscrew (10) which will then allow the ETP end cap (5) to be withdrawn. Remove bearing locknut (3), the ETP sleeve (14) and the bearing assembly can be withdrawn from the rear of the housing (2).

3) The bearings (12) can now be removed along with the bearing spacers (6 and 7) using a bearing puller.

Note: Care must be taken not to damage the ETP sleeve (14).

4) After preparation (see preparation prior to fitting bearings), and lubrication. The new bearings (12) can now be fitted to the ETP sleeve (14) complete with the bearing spacers (6 and 7). Ensure that the bearings (12) are fitted the correct way round. Use only sufficient pressure to fit bearings, applying pressure to the inner ring only. Ensure tha the bearing ring fits up to the location shoulder.

5) Refit ETP sleeve (14) and bearing assembly into the housing (2) ensuring that the assembly fits right up to the shoulder of the housing (2). Refit bearing locknut (3) ensuring that it is tight. Refit sleeve end cap (5) and sleeve locknut (4) insert grubscrews (15).

Note: Ensure all labyrinth seals are re-filled with grease.

Outboard Bearing Housing Removal (Fig 4)

1) Remove outboard bearing assembly from machine.

2) Remove grubscrew (13), remove anti rotation pin (11). Remove the external circlip (8) from the rear of the housing, this will allow the housing assembly to be removed from the front of the machine. Care must be taken not to damage the housing assembly (2) or the mounting plate (1).

3) To refit the housing reverse the previous steps. Re-assembly will be aided by smearing the bore of the housing plate (1) with oil.

Note: Care must be taken when re-assembly not to damage the tape strip (9) in the housing plate (1).



ILLUSTRATED PARTS LIST

CONTENTS

1. Top Head Axial Adjustment
2. Top Head Power Rise And Fall
3. Pad Pressure After Top Head
4. Top Head Chipbreaker
5. Outboard Bearing

**IMPORTANT: WHEN ORDERING SPARES ALWAYS QUOTE
MODEL AND MACHINE NUMBER**

TOP HEAD MODULE

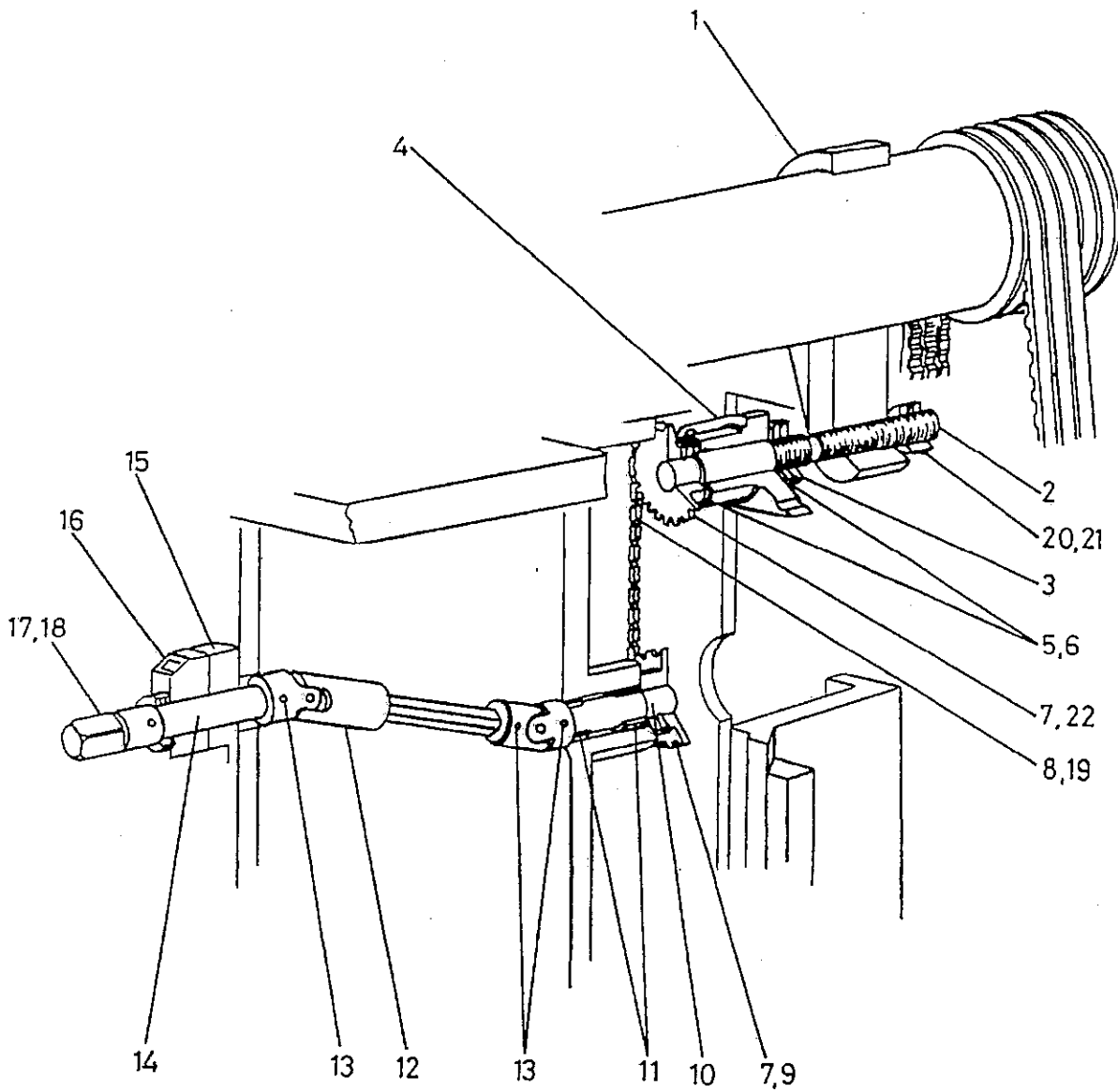

FIG 1 TOP HEAD AXIAL ADJUSTMENT



TOP HEAD MODULE

1. TOP HEAD AXIAL ADJUSTMENT

Ref No.	Description	No.Off
1.	Nut for horizontal head adjustment	1
2.	Shaft for horizontal head adjustment	1
3.	M24 x 1.5 Chamfered notch nut	2
4.	Bearing bracket for horizontal head adjustment	1
5.	'INA' Thrust bearing AXK 2542	2
6.	'INA' Thrust washer AS 2542	4
7.	Sprocket for horizontal head axial adjustment	2
8.	'REYNOLD' Roller chain no. 111046 12.9mm (1/2") pitch, 40 pitches	1
9.	No. 4 Taper pin	1
10.	Shaft	1
11.	20mm I/D x 25mm O/D x 20mm long bronze bush	2
12.	Universal coupling with 12mm A/F telescopic shaft	1
13.	6mm dia. x 24mm long tension pin	1
14.	Shaft for horizontal head cross adjustment	1
15.	Bearing block	1
16.	Digital readout	1
17.	Square shaft extension	1
18.	Taper pin no. 1	1
19.	Chain connector link	1
20.	Threaded collar M20 trapezoidal	1
21.	Hexagon socket grubscrew M8 x 8mm long	2
22.	6mm dia. x 40mm long tension pin	1

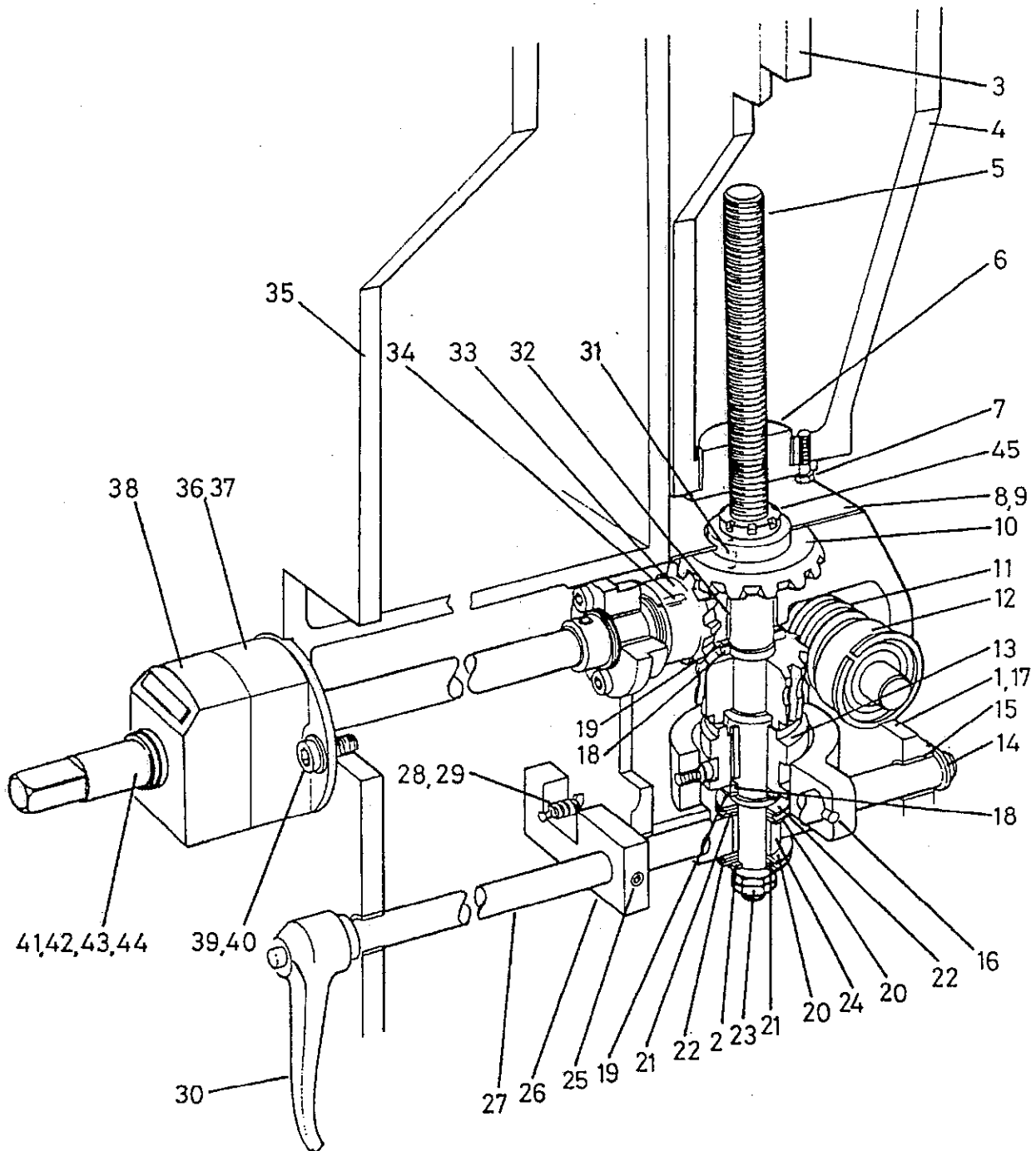

FIG 2 TOP HEAD POWER RISE AND FALL



TOP HEAD MODULE

2. TOP HEAD POWER RISE AND FALL

Ref No.	Description	No Off.
1.	Socket head capscrew M12 x 30mm long	4
2.	Plain washer M16	1
3.	Slide strip	1
4.	Top head vertical slide	1
5.	Vertical rise and fall screw	1
6.	Nut for rise and fall screw	1
7.	Hexagon head setscrew M8 x 25mm long	2
8.	Top cover	1
9.	Hexagon socket capscrew M6 x 8mm long	4
10.	Bevel gear	1
11.	Worm gear	1
12.	Bearing 'SKF' 6204 RS	2
13.	Dog clutch	1
14.	External circlip 16mm dia.	2
15.	Bronze bush 20mm O/D x 16mm I/D x 16mm long	2
16.	Tension pin 6mm dia. x 32mm long.	1
17.	Gearbox/clutch housing	1
18.	Clutch spacer washer	2
19.	External circlip 30mm dia.	2
20.	Thrust washer 'INA' AS 2542	2
21.	Thrust bearing 'INA' AXK 2542	2
22.	Shaft washer 'INA' WS 2542	2
23.	Locknut M16	2
24.	Bronze bush 30mm O/D x 25mm I/D x 20mm long	1
25.	Hexagon socket grubscrew M6 x 10mm long	1
26.	Clutch location arm	1
27.	Clutch adjusting shaft	1
28.	Spring for spindle lock	1
29.	Steel ball 10mm dia.	1
30.	Locking handle M10 x 25mm male	1
31.	Parallel key 8mm x 7mm x 14mm long	1
32.	Bronze bush 35mm O/D x 30mm I/D x 20mm long	1
33.	Bevel gear	1
34.	Parallel key 5mm x 5mm x 20mm long	1
35.	Main frame	1

cont/....

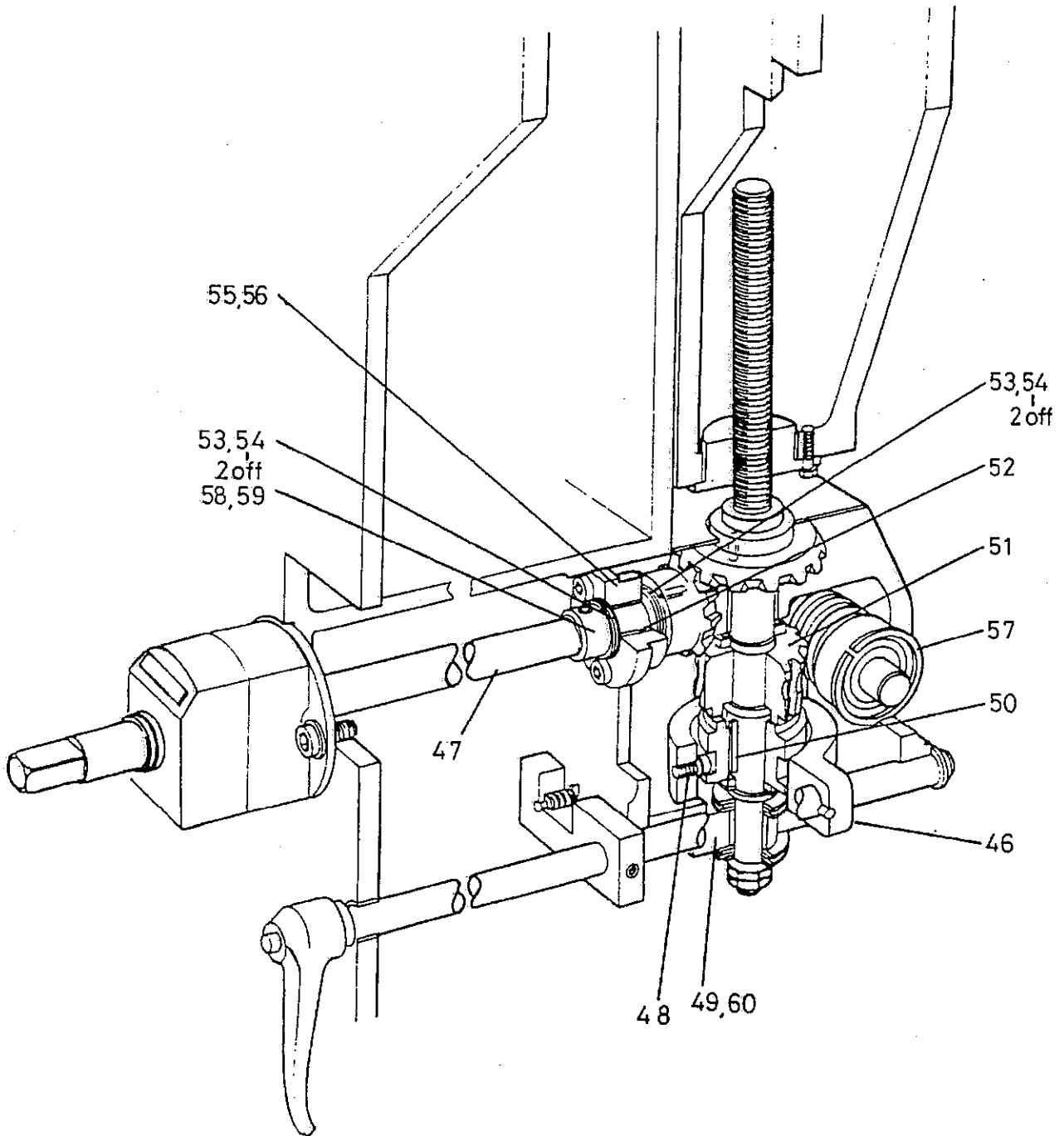

FIG 2 TOP HEAD POWER RISE AND FALL



TOP HEAD MODULE

2 TOP HEAD POWER RISE AND FALL (cont....)

Ref No.	Description	No. Off.
36.	Bearing bracket	1
37.	Bronze bush 25mm O/D x 20mm I/D x 15mm long	2
38.	'SIKO' digital readout 0902E 2mm	1
39.	Hexagon socket capscrew M6 x 20mm long	2
40.	Plain washer M6	2
41.	Square end shaft extension	1
42.	Taper pin No. 1	1
43. +	Compression spring	1
44.	External circlip 25mm dia.	1
45.	Notch nut M24 x 1.5mm	1
46.	Clutch yoke	1
47.	Adjusting shaft	1
48.	Hexagon socket capscrew M6 x 10mm long	2
49.	Bottom cover	1
50.	Parallel key 8mm x 7mm x 32mm long	1
51.	Worm wheel	1
52.	Bronze bush 25mm O/D x 20mm I/D x 25mm long	1
53.	Thrust bearing 'INA' AXK 2035	2
54.	Thrust washer 'INA' AS 2035	4
55.	End cap	1
56.	Hexagon socket capscrew M6 x 20mm long	3
57.	Internal circlip 47mm dia.	2
58.	Collar 32mm O/D x 20mm I/D x 14mm	1
59.	Hexagon socket grubscrew M6 x 6mm long	1
60.	Hexagon socket capscrew M8 x 16mm long	4

+ Not illustrated

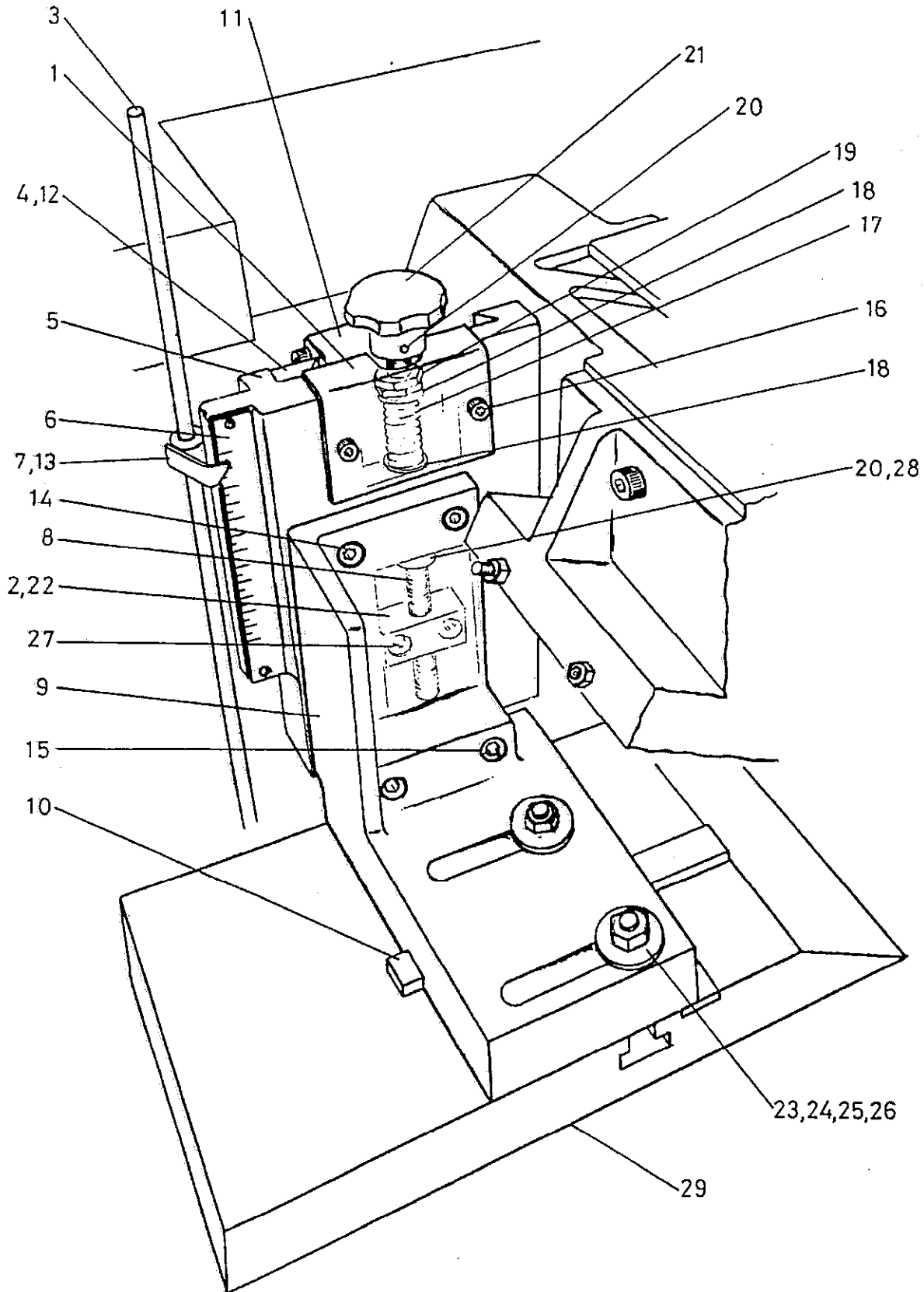

FIG 3 TOP HEAD PRESSURE PAD



TOP HEAD MODULE

3. PAD PRESSURE AFTER TOP HEAD

Ref No.	Description	No Off.
1.	Cover for top head pressure spring	1
2.	Nut for top head pressure adjustment	1
3.	Pointer support first top head.	1
OR	Pointer support second top head	1
4.	Wear strip	1
5.	Saddle for top head pressure	1
6.	0-130mm Metric scale	1
7.	Pointer	1
8.	Screw for top head pressure adjustment	1
9.	Bracket for mounting top head pressure pad	1
10.	Cross tenon	1
11.	Slide for top head pressure	1
12.	Hexagon head setscrew	4
13.	Hexagon socket grub screw M6 x 6mm long	1
14.	Hexagon socket cap screw M10 x 16mm long	2
15.	Hexagon socket cap screw M10 x 50mm long	2
16.	Hexagon socket cap screw M6 x 10mm long	2
17.	Compression spring 'Flexo' 283816	1
18.	Thrust washer 'INA' AS 1226	2
19.	Locknut M12	2
20.	Taper pin	2
21.	Handwheel M12	1
22.	Helicoil insert M12	1
23.	Tee nut 'WDS' 664203	2
24.	Stud M10 x 55mm long	2
25.	Nut M10	2
26.	Plain large washer M10	2
27.	Hexagon socket cap screw M8 x 20mm long	2
28.	Collar	1
29.	Pad pressure shoe	}for machine with
OR	Pad pressure shoe for	}one top head only
	splitting/counter profiling	}
OR	Pad pressure shoe	}for machine with two
	Pad pressure shoe for	}or more top heads
	dia. 125 cutting circle	}
OR	Pad pressure shoe for soft pads (optional)	

TOP HEAD MODULE

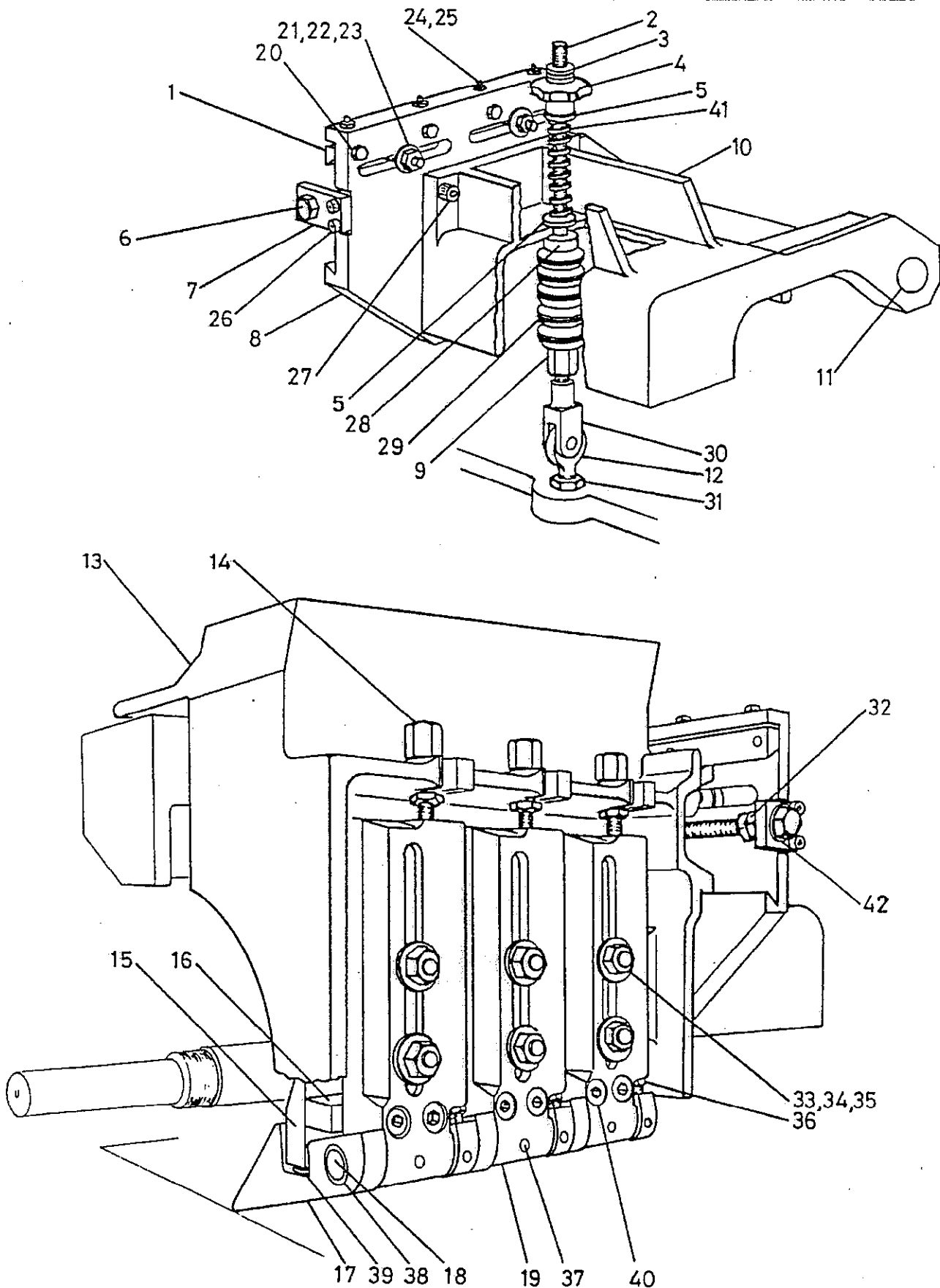

FIG 4 TOP HEAD CHIPBREAKER



4. TOP HEAD CHIPBREAKER MK 111

Ref No.	Description	No Off.
1.	Wear strip	1
2.	Screw	1
3.	Thumb nut 'WDS' 614-204	1
4.	Hand knob	1
5.	Cap for tension spring	2
6.	Adjusting screw	1
7.	Plate for adjusting screw	1
8.	Swing for chipbreaker (front)	1
9.	Stop for top head chipbreaker	1
10.	Swing for chipbreaker (rear)	1
11.	Shaft for chipbreaker pivot	1
12.	Eye bolt	1
13.	Hood for chipbreaker carrier	1
14.	Adjusting screw for top chipbreaker	3
15.	Baffle/spring housing	3
16.	Block for spacing baffle	3
17.	Shoe for chipbreaker	3
18.	Pin for chipbreaker shoe pivot	3
19.	Bracket for mounting chipbreaker shoe	3
20.	Hexagon head setscrew M8 x 20mm long	4
21.	Stud M12 x 50mm long	2
22.	Large washer M12	2
23.	Nut M12	2
24.	Hexagon head grubscrew M6 x 20mm long	4
25.	Locknut M6	4
26.	Hexagon socket capscrew M6 x 16mm long	2
27.	Hexagon socket capscrew M12 x 30mm long	4
28.	Collar 40mm O/D x 25mm I/D x 16mm wide	1
29.	Disc springs 50mm O/D x 25.4mm I/D x 1.5	10
30.	Rod clevis festo SG M12	1
31.	Nut M12	1
32.	Lock screw M12	2
33.	Stud M12 x 65mm long	6
34.	Washer M12	6
35.	Nut M12	6
36.	Hexagon head setscrew M6 x 30mm long	3
37.	Hexagon socket grubscrew M6 x 10mm long	3
38.	Oilite bronze bush 20mm O/D x 16mm I/D x 12mm long	6

cont/...

TOP HEAD MODULE

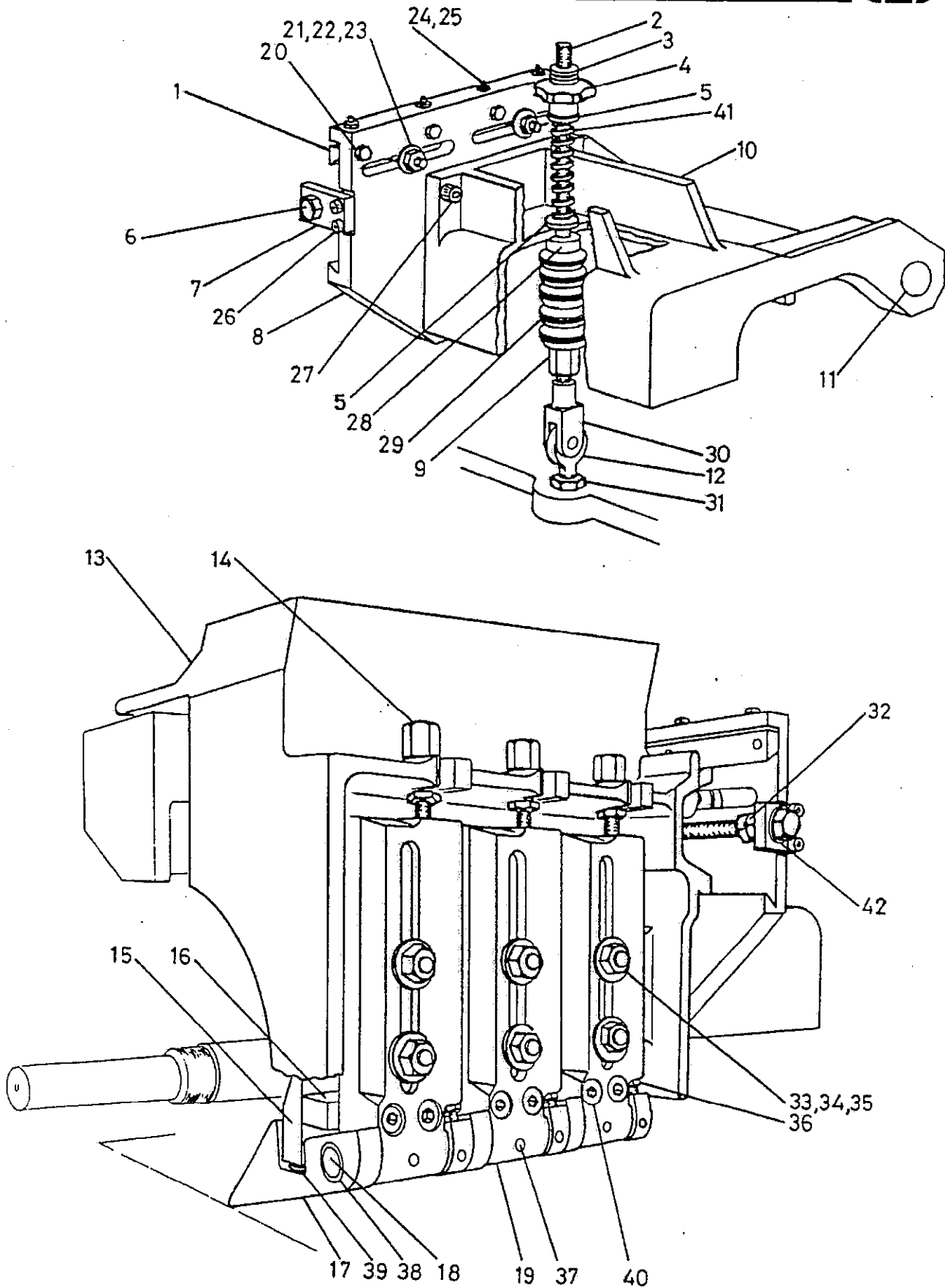

FIG 4 TOP HEAD CHIPBREAKER



TOP HEAD MODULE

4. TOP HEAD CHIPBREAKER MK 111 (CONT....)

Ref No.	Description	No Off.
39.	Compression spring	1
40.	Hexagon socket capscrew M10 x 60mm long	6
41.	Compression spring 135mm long x 28.2 O/D x 21.8 I/D	1
42.	Thrust washer 'INA' AS 1226	2

TOP HEAD MODULE

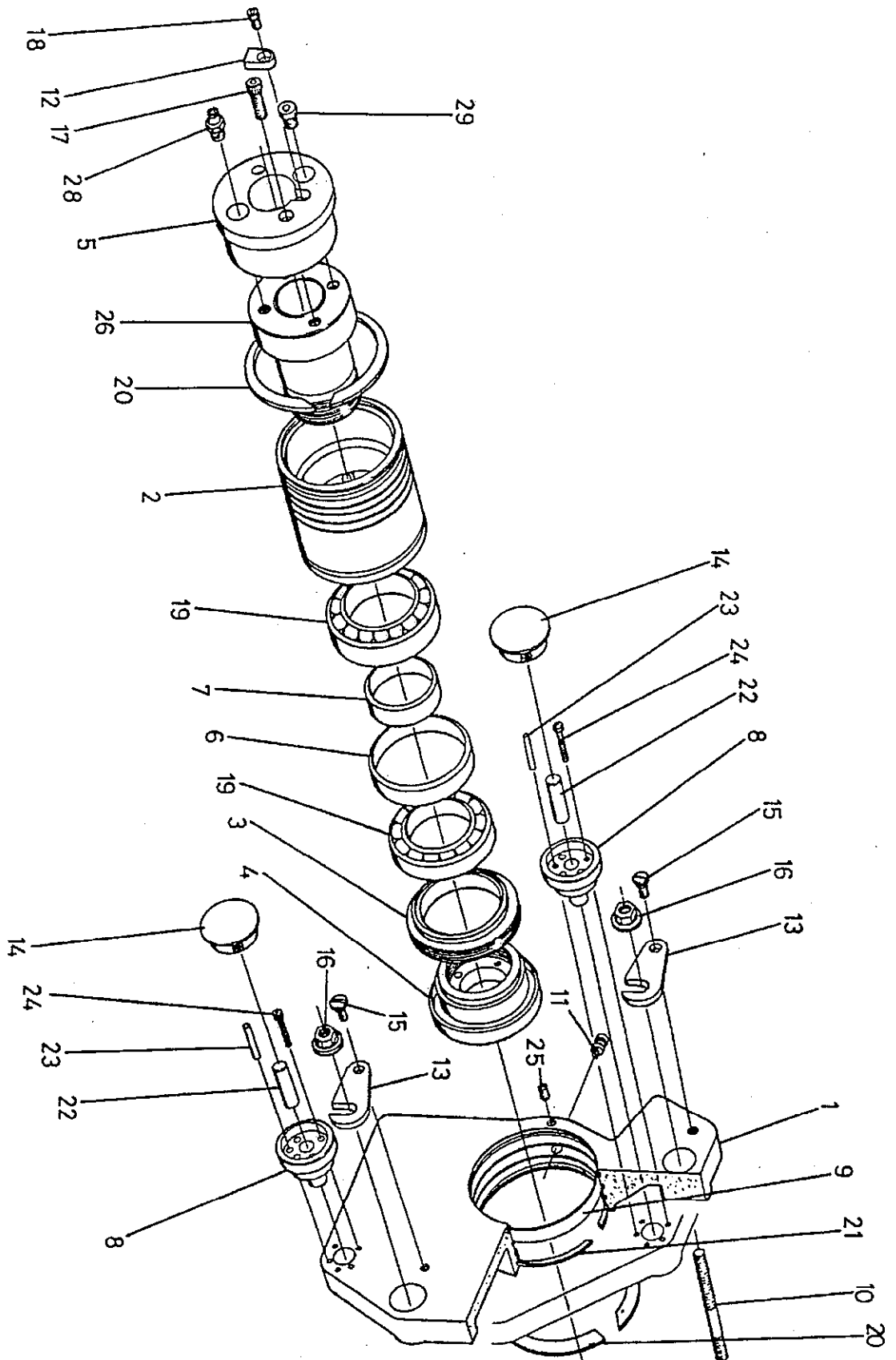

FIG5 OUTBOARD BEARING → TOP HEAD



5. OUTBOARD BEARING - MK 111 TOP HEAD

Ref No.	Description	No Off.
1.	Plate for mounting outboard bearing housing	1
2.	Housing for adjustable outboard bearing	1
3.	Locknut for outboard bearing housing	1
4.	Locknut for hydro grip sleeve	1
5.	End cap for hydro grip sleeve	1
6.	Outer bearing spacer } supplied as matched	1
7.	Inner bearing spacer } pair	1
8.	Knob for outboard location	2
9.	Tape strip for outboard bearing housing	2
10.	Stud for outboard bearing plate	1
11.	Anti rotation pin for housing	1
12.	Drive key	1
13.	'C' Washer	2
14.	DP 2000, 2783 black plug	2
15.	Shoulder screw 'WDS' 615-203	2
16.	Collar nut 'WDS' 404-204 M12	2
17.	Hexagon socket capscrew M5 x 12mm long	2
18.	Hexagon socket capscrew M3 x 12mm long	1
19.	'RHP' bearing 7911 x 2 TAU EP7	2
20.	'INA' external circlip WR95	2
21.	'INA' internal snap ring BR100	4
22.	Plain dowel dia. 12 x 45mm long	2
23.	Tension pin dia. 6 x 32mm long	4
24.	Hexagon socket capscrew M6 x 30mm long	6
25.	Hexagon socket grub screw M6 x 16mm long	1
26.	ETP sleeve (less front plate)	1
27.	Pressure relieve valve } items only supplied	1
28.	Grease nipple } with ETP sleeve	1

SECTION 10 TOP HEAD/BOTTOM HEAD MODULE

General (Fig 1)

This module has a top head followed directly by a bottom head. Timber is fed through the unit by a single top feed roll and an opposed top/bottom roller combination at the outfeed end. Drive to the through feed rollers is via 'siti' gearboxes at the rear of the module (see chapter - Gearboxes and Drive Shafts).

A small amount of adjustment is catered for on the horizontal heads.

Note: The machine is factory set to give 12mm movement backwards from the datum face of the fence when it is set at ZERO.

If it should be necessary to obtain further lateral movement when at the maximum rearward position, it may be obtained by first isolating the power at the master stop or mains, removing the pulley guard and releasing the belt tension (see Maintenance - Vee Belt Drive Tensioning). Move the belts onto the next vacant pulley groove to bring them back into line and then re-tension the belts.

Locking collars prevent the spindle movement exceeding the original factory set boundaries and therefore if the belts are repositioned, then the rear stop (1) must also be reset.

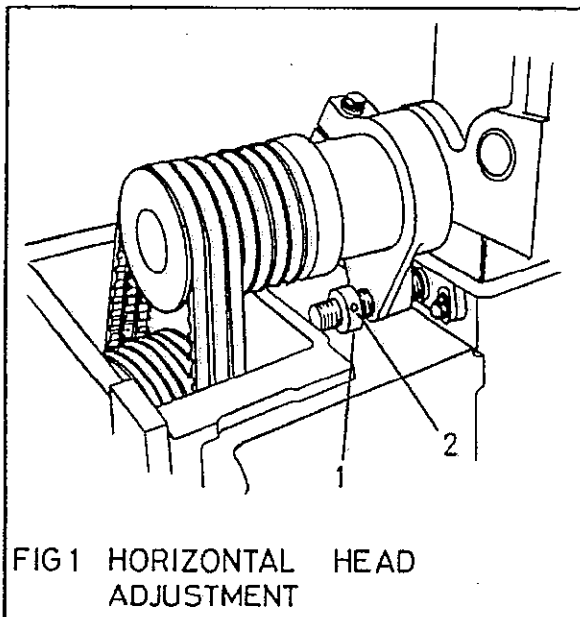

This may be done by slackening off the grub screw (2), moving the collar back a further 12mm and then retightening the grub screw (2).

Top Head Vertical and Horizontal adjustment (Fig 2, Fig 3)

Before making any horizontal adjustment ensure that the jointer is 'parked' clear (see chapter - Jointers).

Horizontal Adjustment

- 1) Isolate power at master stop or mains.
- 2) Release the spindle barrel lock (2).
- 3) Adjust using the handscrew (1).
- 4) Tighten barrel lock (2).

Manual Vertical Adjustment - Top Head Only

Note: The outboard bearing support is hydraulically locked into position and **MUST** be released before any vertical adjustment is made. The lock and unlock control buttons are found on the main control cabinet and on the infeed and outfeed subcontrol stations (6) depending on moduler assembly.

- 1) Release hydraulic locks (7) by pressing button indicated thus <|>. Then isolate power supply at master stop or at mains.
- 2) Ensure bed is clean.
- 3) Remove jointer cover (3) by slackening off thumbscrews (4) or remove blanking cover if no jointers are fitted. This allows easy access to cutter.



- 4) Place a datum block (5) of known thickness under the cutterblock.

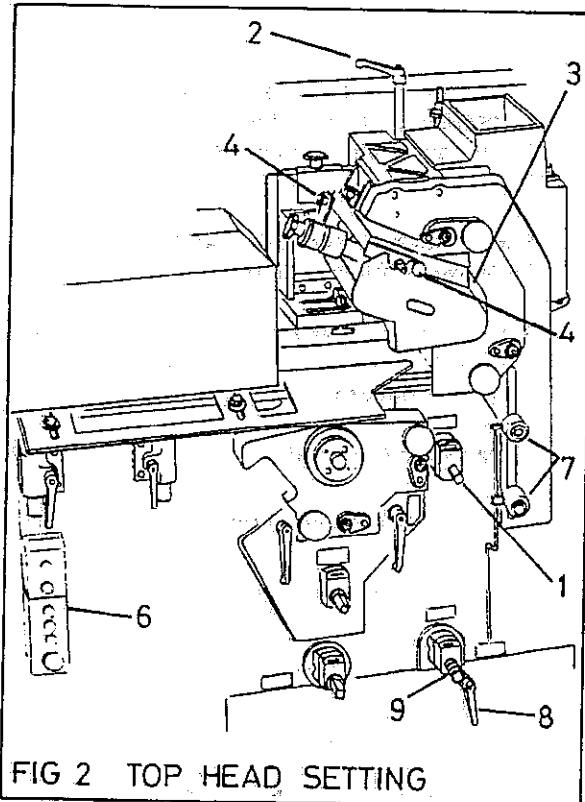

FIG 2 TOP HEAD SETTING

- 5) Rotate the handscrew (9) clockwise to lower the spindle or anti-clockwise to raise the spindle. The knives should just touch the block when the spindle is rotated slowly by hand via the outboard bearing.

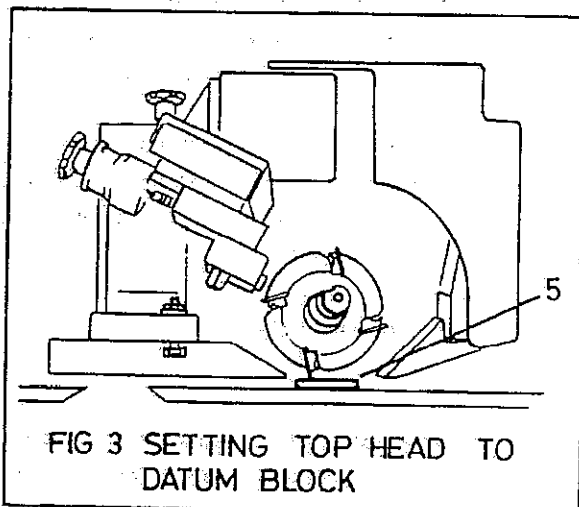

FIG 3 SETTING TOP HEAD TO DATUM BLOCK

- 6) When setting to a datum block check the digital readout. If necessary reset the counter by loosening grub screw in collar of the readout and then turning collar until the reading coincides to the thickness of the datum block. When set remove block.
- 7) Set head to desired position and replace cover (3).
- 8) Switch power on and engage hydraulic locks by pressing button indicated *.

Electrical Vertical Adjustment - Top Head and Beam

Note: The powered vertical adjustment of the beam is electrically interlocked with the Top head and cannot move until the hydraulic locks are disengaged.

- 1) Release outboard bearing support locks by pressing button marked thus $\leftarrow \rightarrow$. The lock and unlock buttons are found on the main control cabinet or on the infeed sub control station.
- 2) Engage clutch lever (8). If the clutch does not readily engage, turn the handscrew (9), slightly to the left or right until it engages.
- 3) To raise the head/beam press the button marked '↑'. The button with the downward pointing arrow moves the head/beam down. These buttons again are found on the main control cabinet or on the infeed sub station.
- 4) When in the required position re-engage locks by pressing button marked * . Disengage clutch.



Top Head Chipbreaker and Pad Pressure (Fig 4)

Ensure power is isolated from machine. The bed should be clean and the cutterblock already 'set up'. Place a straight edge on the table under the pad pressure, cutterblock and chipbreakers. When set all three should be in line with each other.

To Adjust Pad Pressure

- 1) Use adjusting screw (1) to raise and lower pad.

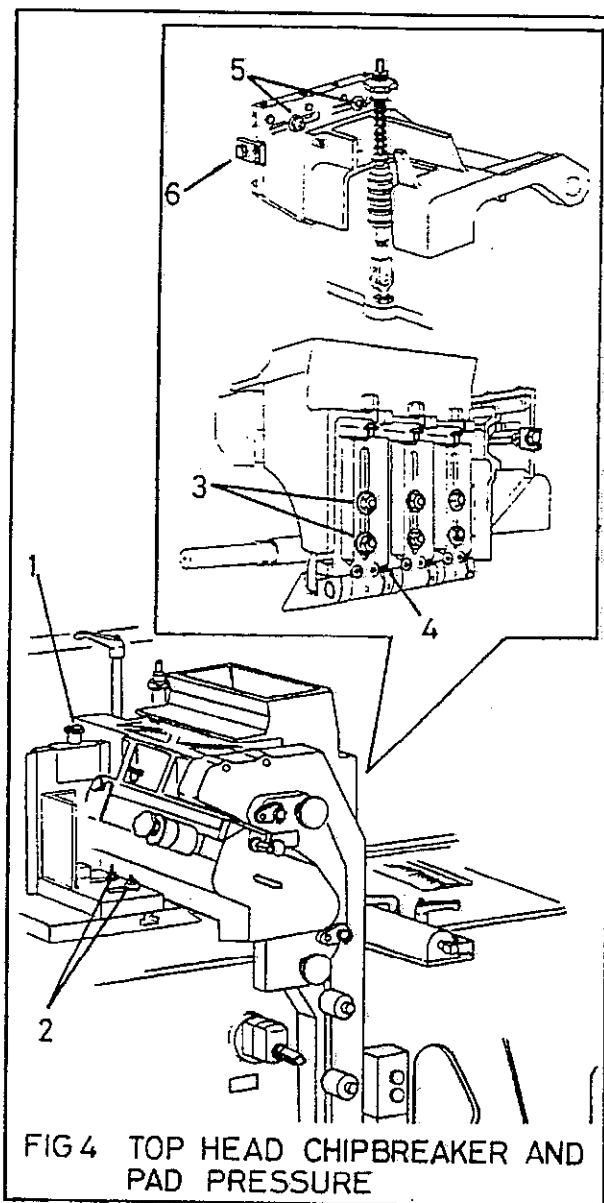

FIG 4 TOP HEAD CHIPBREAKER AND PAD PRESSURE

- 2) Slacken off pad pressure locking nuts (2) and laterally position the pad nose 5mm clear of the maximum cutting circle. Also position pad width wise to suit timber.

- 3) Retighten nuts (2)

To Adjust Chipbreaker

The chipbreaker is made up of a bank of three individual units each positioned in a similar way.

Set the height of each unit as follows.

- 4) Slacken off the two locknuts (3).
- 5) Raise/lower the chipbreaker unit until the nose touches the straight edge placed under the pad pressure after the top head.
- 6) Tighten the locknuts (3).
- 7) A stop screw (4) provides for small adjustment to align all the chipbreaker nose pieces.

Lateral adjustment

- 8) Slacken off the two locknuts (5) at the rear of the top head and turn the adjusting screw (6) until the chipbreaker nose is approximately 20mm from the cutter knives.

- 9) Fasten rear locknuts (5).

Bottom Head Vertical and Horizontal Adjustment (Fig 5, Fig 6)

Spindle adjustment where provided may be adjusted within its limits in both planes from the front of the module.

To Check Cutterblock Height

- 1) Isolate power supply at mains or by using master stop.



- 2) Remove/raise guards to allow clear access to bedplates and cutterblock.
- 3) Ensuring bedplates are clean place a straight edge (1) on the outfeed table of the module projecting over the bottom horizontal cutterblock. If set correct the blades should just touch the underside of the straight edge. Adjust cutterblock height if necessary.

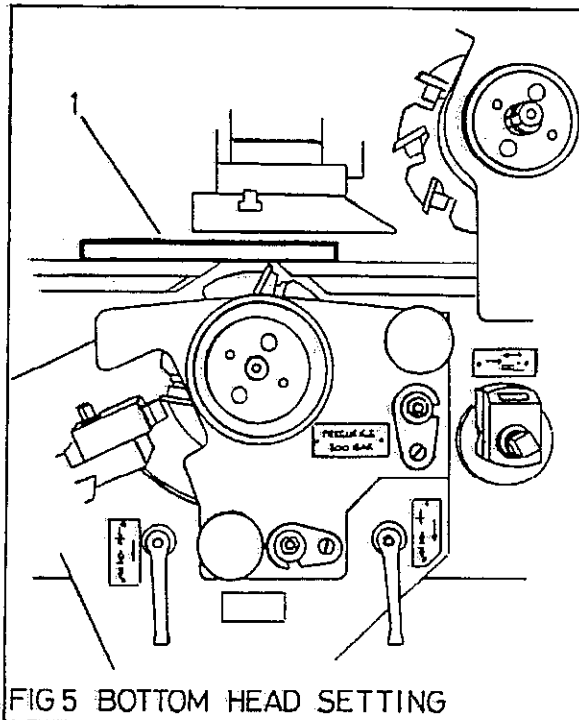

FIG 5 BOTTOM HEAD SETTING

Vertical Adjustment

- 4) Isolate power supply at mains or at master stop if not already isolated.
- 5) Release outboard housing locking handles (2).
- 6) Using supplied winding handle rotate adjusting screw (3) clockwise to raise the spindle or anti-clockwise to lower.
- 7) When the correct height has been achieved tighten locking handles (2) and engage power if no further adjustments are necessary.

Horizontal Adjustments (if fitted)

- 8) Ensure power is isolated at mains or at master stop. Remove conical outboard bearing cover.
- 9) Before making any lateral adjustment first release the spindle barrel lock (4).

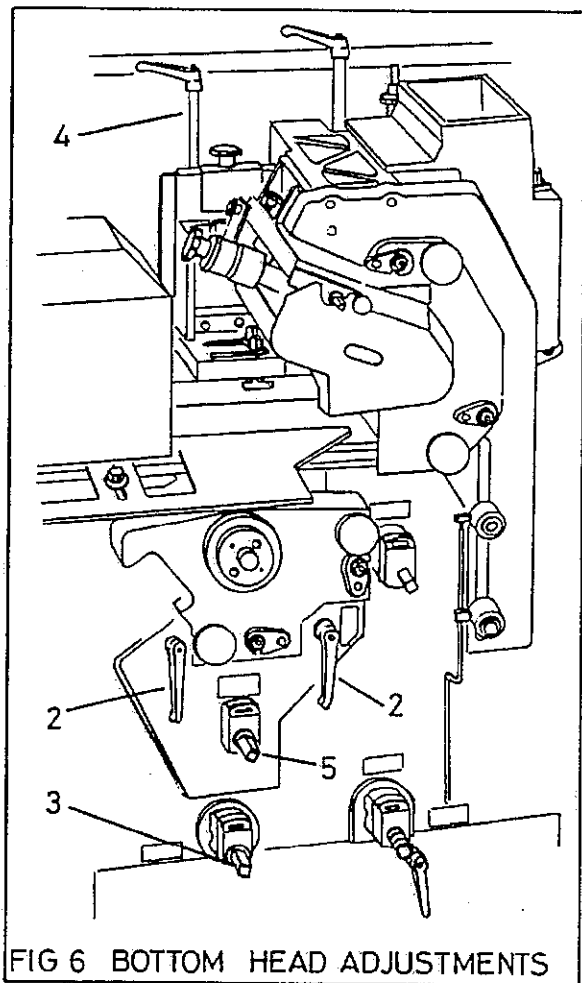

FIG 6 BOTTOM HEAD ADJUSTMENTS

- 10) Position cutterblock as required using adjusting screw (5).
- 11) Refasten spindle barrel lock (4). Replace cutboard cover and engage power if no further adjustments are required.

Adjustment to Top and Bottom Through Feed Rollers

For information relating to adjustment, maintenance and parts refer to chapter - Driven Bed Rolls and Top Through feed Rollers.

Adjustment of Side Guide (Fig 7)

The side guide as its name suggests is designed to guide the timber through the machine.

As such when set there should be no positive pressure on the timber just a light rubbing action.

- 1) To set the width slacken the two locknuts (1). Adjust the guide to suit the finished timber width. Ensure the guide is parallel to the fence. Refasten locknuts.
- 2) The side guide height is adjusted by slackening the two locking handles (2) and altering the height to suit the timber section. Normal practice is to leave the side guide at bed level and only adjust its height if the timber has a moulded edge. Then it would be necessary to adjust the guide to 'run' on a flat of the moulding. After adjustment refasten locking handles.

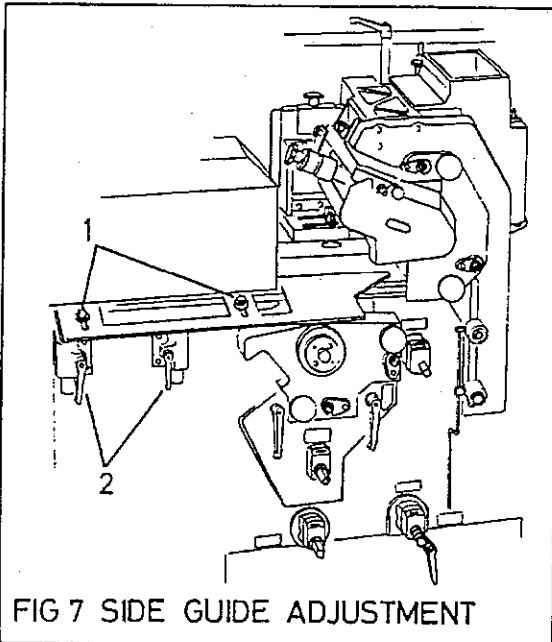



MOUNTING THE CUTTERBLOCKS

General

The XJS machine can be fitted with plain bore or Hydrogrip (hydraulic pressure) cutterblocks. Hydrogrip cutterblocks are used to provide an improved surface finish and allow higher feed speeds to be used. The method of fitting the two types differs.

When changing cutterblocks, be aware that the spindles for plain bore blocks have right or left hand threads, dependent on spindle location, and tighten accordingly.

The spindles are threaded as follows:

Bottom Horizontal Spindles - Left Hand Thread

Top Horizontal Spindles - Right Hand Thread

The Hydrogrip blocks are not screw fitting and require to be pressurised in position on the spindle. To protect the Hydrogrip cutterblock and the machine spindle in the event of hydraulic failure, it is necessary for safety drive collars to be used.

The consequence of not using the safety drive collars will result in the cutterblock seizing on the machine spindle in the event of either; the operator neglecting to pressurise the cutterblock and then running the spindle, or the Hydrogrip cutterblock sleeve losing pressure.

If a seizure occurs, the spindle and cutterblock must be returned to Wadkin for repair. An appropriate charge will be made for this service.

Two types of safety collar are used. These are a threaded safety collar; for use when full length tooling is in use on the machine spindle. A plain safety collar; for use when short length tooling is used on the machine spindle.

Outboard bearings are fitted to the horizontal spindles to give greater rigidity to the cutterblock; these support each spindle at its outer position.

The outboard bearing support bracket on the bottom heads is attached and locked to the support plate manually. The top heads are hydraulically locked from the control panel or side locks and are interlocked to the powered rise and fall of the spindle to ensure the plate is free to move with the spindle. The bearing plate locks on either head must be released before making vertical adjustments to that head. Once the locks on the top head are released the power can be isolated before commencing to change/alter cutterblocks. Power to the bottom head should be isolated prior to any work being carried out.

To Change Cutterblocks on Top and Bottom Heads (Fig 1, Fig 2, Fig 3)

The method of changing cutterblocks depends on the type fitted and it will be first necessary to remove any outboard bearing, locking collar, spindle nut, and spacers fitted, as applicable. Isolate machine from power source.

- 1) Open/remove covers to allow access to and removal of outboard bearing housing.

- 2) Depressurise the outboard bearing (6) by turning the pressure valve (2) one quarter of a turn using a 3mm Allen key.
- 3) Ensure the pad pressure and chipbreaker on the Top head and jointers (if fitted) on both heads are well clear of the cutterblock especially if replacing it with a larger cutting circle block.
- 4) Slacken off the two 12mm collar nuts (3), swing captive 'C' washers (4) clear and remove outboard bearing housing (5).
- 5) Remove cutterblock off spindle. When handling cutterblocks care should be taken to avoid injury on knife blades. The method of removal of the cutterblocks varies depending on the block type.

a) Plain Bore Cutterblock

Unscrew the cutterblock nut from the spindle with the spanner/s provided. Can be right or left hand thread (see General).

Place the spanner/s on the hexagon of the spindle and the two flat faces of the cutterblock locknut, or;

Hold the spanner (top) securing the spindle firmly in position and unscrew the cutterblock locknut from the spindle with the bottom spanner.

Note: DO NOT use any form of percussion tool or damage to spindle bearings can result. DO NOT use a box or extension spanner.

b) Hydrogrip Cutterblock with Plain Collar

Release the capscrew in the collar using an Allen key. This causes the collar to loosen its grip on the spindle and slide off.

Note: On reassembly ensure this collar is fitted with locating pins facing

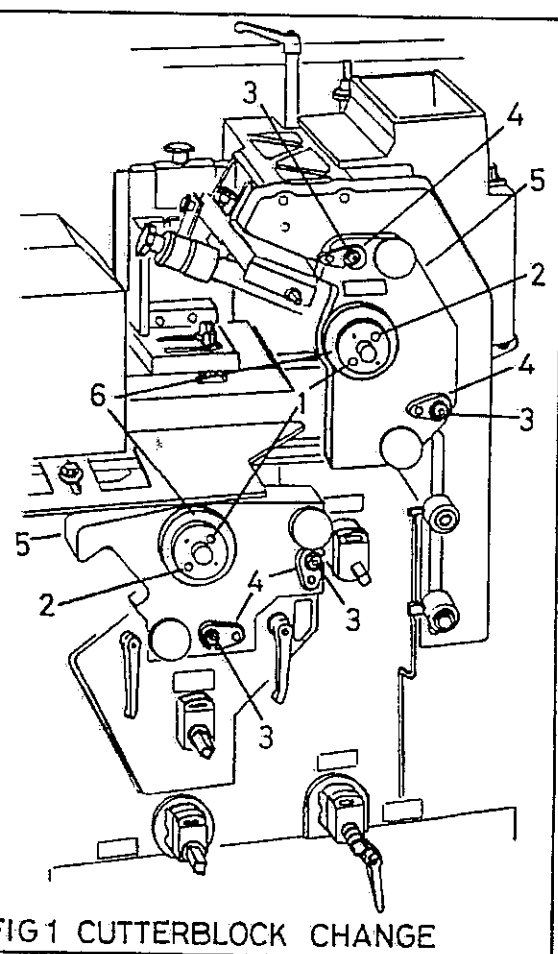

FIG 1 CUTTERBLOCK CHANGE

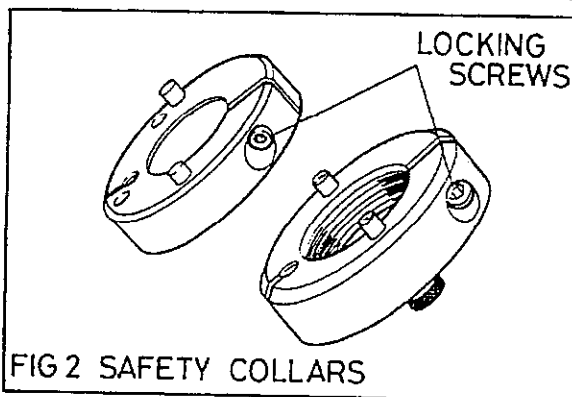
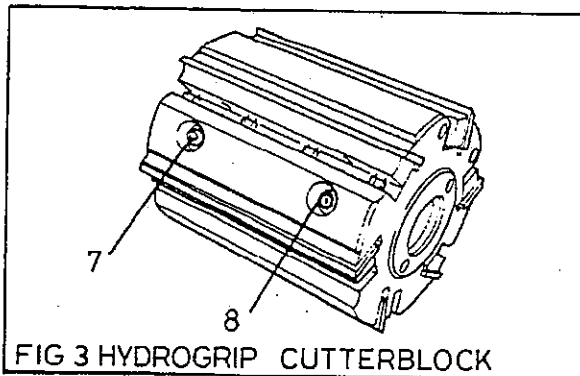

FIG 2 SAFETY COLLARS

Depressurise the hydrogrip cutterblock by turning the pressure release screw (8), located in a recess on the barrel of the cutterblock one quarter turn to release, using a 3mm A/F hexagon key.

Slide the cutterblock from the spindle.



Always leave the pressure release screw (8) undone when the cutterblock is not in use to avoid distortion to the cutterblock due to the variation in room temperatures.

c) Hydrogrip Cutterblock with Threaded Collar

Release the capscrew in the collar using an Allen key. Unscrew the two knurled headed pins until the collar itself is free to unscrew.

Note: On reassembly this collar must be screwed finger tight against the pressurised block and then, if needed, unscrewed until the pins line up with the corresponding cutterblock holes.

Depressurise the hydrogrip cutterblock by turning the pressure release screw (8), located in a recess on the barrel of the cutterblock one quarter turn to release, using a 3mm A/F hexagon key.

Slide the cutterblock from the spindle.

Always leave the pressure release screw (8) undone when the cutterblock is not in use to avoid distortion to the cutterblock due to the variation in room temperatures.

- 6) Before replacing cutterblock ensure spindle, spindle shoulder, shoulders of cutterblock and bores are all clean.
- 7) Carefully place the cutterblock on the spindle. On the hydrogrip blocks tighten pressure release screw (8), and pressurise the cutterblock by applying hydraulic pressure to the pressure nipple (7) located in a recess located on the barrel of the block (see Fig 3).
- 8) Fit safety collars and/or spacers as applicable. On the plain bore cutterblocks, tighten the block to the spindle with the spanner/s provided.
- 9) Replace bearing housing (5) and retighten captive 'C' washer (4) and collar nuts (3). Tighten pressure release valve (2) and pressurise bearing to 300 bar (4350 p.s.i) by application of hydraulic pressure to the nipple (1) in the recess on the face of the bearing. **NB.see page 10-10**
- 10) Rotate spindle slowly by hand to check knives are clear of chipbreaker, pad pressure etc. Replace outboard bearing cover, engage power and start head for a short period of time to ensure cutterblock is running smoothly and without vibration.

**NB. Before pressurising the outboard bearing,
set the bearing in the mid position of its axial
adjustment, to allow for final setting of the
cutter block.**

MAINTENANCE

Routine Maintenance

Caution: Before proceeding with any maintenance ensure power is off at mains or at master stop.

Weekly

It is recommended that the machine be cleaned thoroughly once a week, especially when working on hardwood or highly resinous material, to prevent choking of ventilator airways and build-up of deposits on working parts.

Clean all spindles regularly and remove all remains of resin and grease. Do the same with cutterblock collars and machine tables. Check that all machine parts slide, or rotate freely. Lightly lubricate as directed, do not over-lubricate.

If cleaning with compressed air, take care not to direct the jet onto the spindle bearing housings, moving shafts, etc., and avoid forcing dust and debris into bearings and housings.

Centralised lubrication points at the front of the machine allows for oiling of the Top and Bottom head slidways as part of an overall oiling operation.

The slidways should be oiled at weekly intervals. Once lubricated the heads should be traversed to their maximum and minimum positions to ensure even distribution of oil and to prevent sawdust/resin 'build-up' on slideways. 'Wadkin' Grade L4 oil should be used (see **Approved Lubricants**).

Three Monthly (Fig 1)

Electric drive motors have sealed for life bearings and are maintenance free.

However the fan cowls should be removed at intervals and the fans checked for damage, excessive end float, signs of overheating etc. If a cowl itself is damaged it should be replaced.

At the rear of the module remove the covers over the Top and Bottom head spindle pulleys. Clean and grease using Wadkin L6 grease (see **Approved Lubricants**) the spindle barrel lateral adjustment screws (1). Whilst the covers are off also check tension and condition of drive belts. The belts (2) should be capable of being depressed approximately 1 1/2 to 2cm per metre of span by application of average thumb pressure of 2.2 - 3.2 kgf (5-7 lb). If necessary retension (see **Vee Belt Drive Tensioning**)

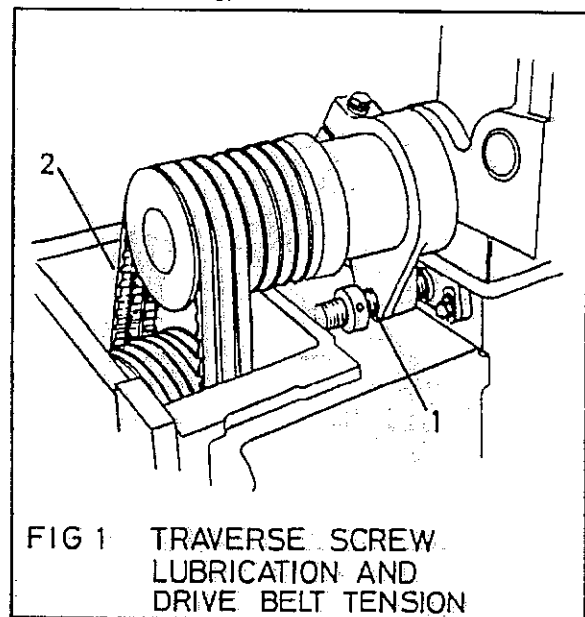

FIG 1 TRAVERSE SCREW LUBRICATION AND DRIVE BELT TENSION

Vee Belt Drive Tensioning (Fig 2)

It is important that drive belts are correctly set as insufficient tension causes slipping and

premature belt wear. Too much tension causes bearing wear. The method of adjustment is as follows.

- 1) Isolate power at master stop or mains.
- 2) Remove cover to expose spindle pulley and belts (Fig 1).
- 3) Slacken off motor mounting plate bolts (1).
- 4) Tension belt by slackening the top locknut (2) and turning the bottom locknut (3) in an anti-clockwise direction.

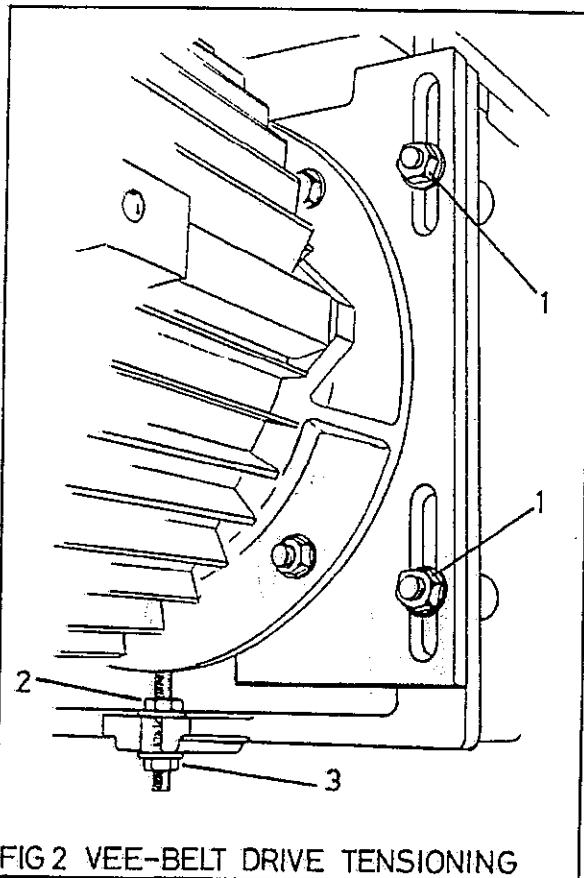

- 5) When tensioned lock up both nuts (2 and 3) and motor mounting bolts (1). Refit cover and engage power

There may be occasions where the tensioning arrangement does not follow that described.

However, all belt drive adjustment follows the same general principle:

This involves moving the drive pulley centres or motor platform, thus taking up any slack in the belt drive. The method used will normally be self evident. Always retighten any securing features fitted.

If one or more of the vee-belts becomes faulty it will usually be necessary to replace as a complete set (see Replacing Drive Belts). It is impossible to obtain a correctly tensioned drive, with all belts taking an equal share of the load, by mixing old and new, or different belts.

Replacing Drive Belts (Fig 2)

Drive belts must be replaced as a set to obtain correct drive performance.

- 1) Isolate power at master stop or mains.
- 2) Remove cover.
- 3) Relieve tension on belts by reducing drive centres i.e. slacken off the four motor mounting bolts (1), the locknut (3) and raise the motor by rotating nut (2) in a clockwise direction.
- 4) Remove old drive belts and fit a new set of belts of the same size, type and reference (see Motor and Drive Belt Data).
- 5) Retension the new belt set (see Vee Belt Tensioning).

Note: It may at times be necessary to remove a drive pulley. The motor shaft pulleys are fitted with taper lock bushes (see fig 3). Spindle pulleys are located on tolerance rings and held on by spigot washer and screw.

Removal and Refit of Drive pulleys (Fig 3)

To remove a Taper-lock bush pulley:

- 1) Slacken off all screws (1) several turns using a hexagonal key. Remove one or two screws according to number of jacking holes (2).
- 2) Insert screws in jacking holes after oiling thread and point of grub screws, or thread and head of capscrews, as applicable.
- 3) Tighten screws (1) alternatively until bush (3) is loosened in pulley hub and assembly is free on shaft.
- 4) Remove pulley assembly from shaft.

To refit a Taper-lock bush pulley:

- 1) Ensure that mating taper surfaces are completely clean and free from oil or dirt. Insert bush in hub and line up screw holes.
- 2) Oil thread and point of grub screws, or thread and head of capscrews. Place screws (1) loosely in threaded holes in hub of pulley.

- 3) Clean shaft, fit hub and bush to the shaft as a unit. Locate in position. On fitting; the bush will nip the shaft first, then hub will be drawn onto bush.

Note: It is necessary to axially align drive and driven pulleys.

- 4) Using a hexagon key, alternatively tighten screws (1) until all screws are pulled up securely. Use a short length of pipe on key to increase leverage.

- 5) After the drive has been running under load for a short time stop and check tightness of screws. Tighten if needed.

- 6) Fill all empty screw holes with grease to exclude dirt.

Preparation Prior to Fitting Bearings

Before fitting a new bearing, the protection lubricant must be meticulously removed with petroleum spirit, triethanolamine, or other volatile solvent.

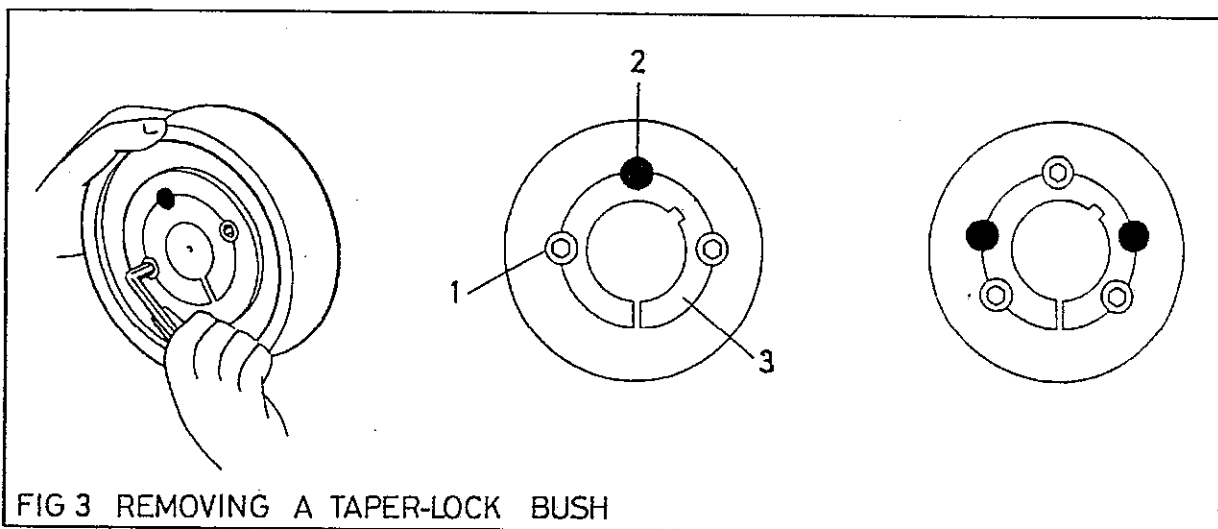

FIG 3 REMOVING A TAPER-LOCK BUSH

In order to prevent the moving parts from being damaged by drying out due to over cleaning, add a small amount of the bearing lubricant to the cleaning agent at the second bath. The film of grease which remains after the solvent has evaporated will provide protection for the bearing until charged with lubricant.

The new bearings should be charged with 'Kluber' lubricant, type 'Isoflex' NBU 15. It is important that the correct amount of grease is applied, preferably using the formula:

$$G \text{ (weight in grams)} = d \times B \times 0.1$$

d = bore of bearing in mm

B = width in mm

This is approximately sufficient to fill one third of the bearing volume.

Outboard Bearing Change for Top and Bottom Heads (Fig 4, Fig 5)

Note: Work must take place in a clean and dry environment, failure to do so could result in premature bearing failure.

Isolate power at mains or at master stop before proceeding.

- 1) Remove outboard bearing assembly from machine (see **Changing Cutterblocks**).

Note: It is not necessary to remove the housing assembly (2) from the mounting place (1), unless the housing (2) has become damaged. To remove see later note 'Housing Removal'.

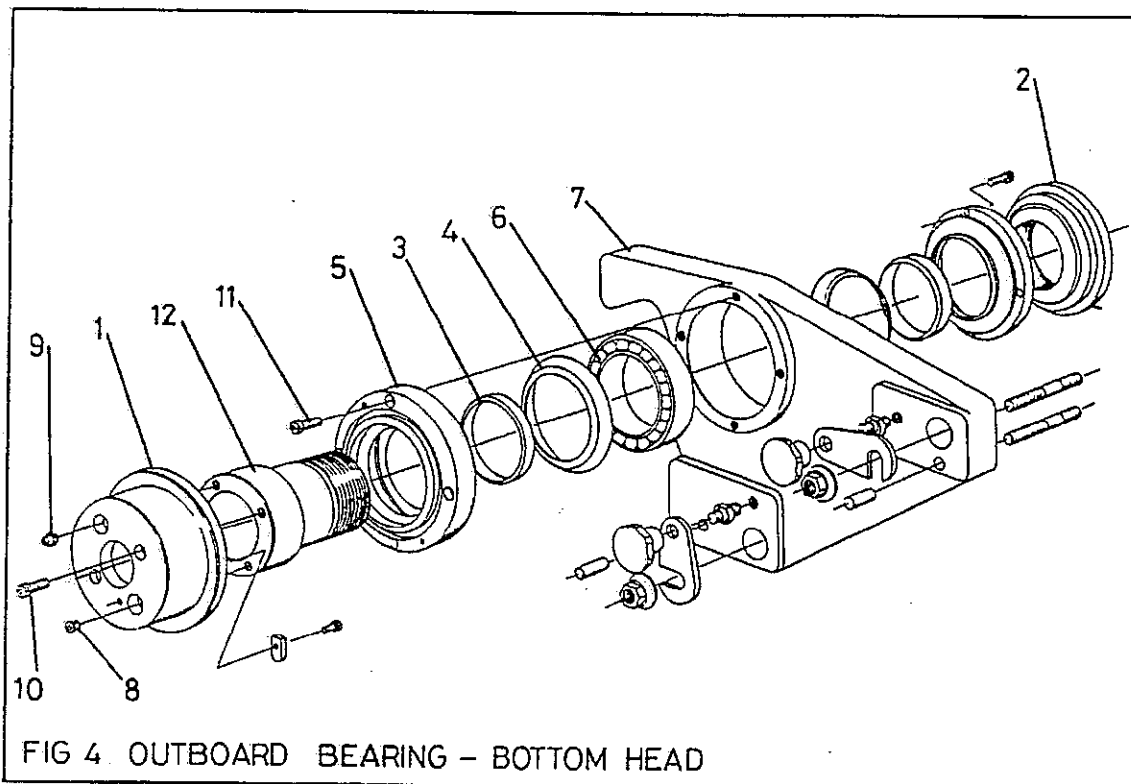

2) Remove 2 off grubscrew (15). Remove ETP sleeve locknut (4), remove 2 off hexagon socket capscrew (10) which will then allow the ETP end cap (5) to be withdrawn. Remove bearing locknut (3), the ETP sleeve (14) and the bearing assembly can be withdrawn from the rear of the housing (2).

3) The bearings (12) can now be removed along with the bearing spacers (6 and 7) using a bearing puller.

Note: Care must be taken not to damage the ETP sleeve (14).

4) After preparation (see Preparation Prior to Fitting Bearings), and lubrication. The new bearings (12)

can now be fitted to the ETP sleeve (14) complete with the bearing spacers (6 and 7). Ensure that the bearings (12) are fitted the correct way round (back to back). Use only sufficient pressure to the inner ring only. Ensure that the bearing ring fits up to the location shoulder.

5) Refit ETP sleeve (14) and bearing assembly into the housing (2) ensuring that the assembly fits right up to the shoulder of the housing (2). Refit bearing locknut (3) ensuring that it is tight. Refit sleeve end cap (5) and sleeve locknut (4) insert grubscrews (15).

Note: Ensure all labyrinth seals are re-filled with grease.

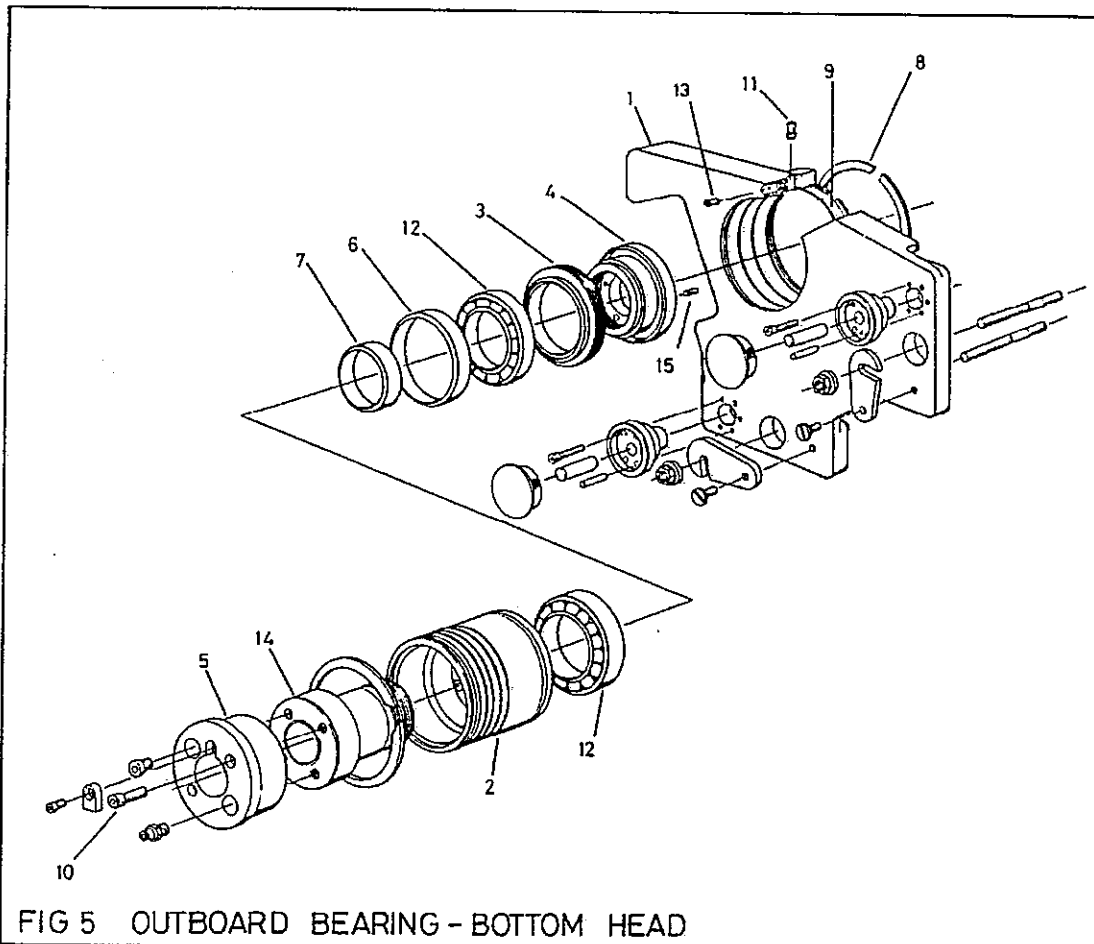

FIG 5 OUTBOARD BEARING - BOTTOM HEAD



Outboard Bearing Housing Removal - Top and Bottom Heads (Fig 4, Fig 5)

- 1) Remove outboard bearing assembly from machine (see **Changing Cutterblocks**).
 - 2) Remove grubscrew (13), remove anti rotation pin (11). Remove the external circlip (8) from the rear of the housing, this will allow the housing assembly to be removed from the front of the machine. Care must be taken not to damage the housing assembly (2) or the mounting plate (1).
 - 3) If the housing has been subject to excessive heat, the bearing tape (9) may have shrunk. Depending on the shrinkage it may need to be replaced or just shimed out. When fitting new bearing tape the edges should be 'feathered' at the joint.
 - 4) To refit the housing reverse the previous steps. Re-assembly will be aided by smearing the bore of the housing plate (1) with oil.
- Note:** Care must be taken when re-assembly not to damage the tape strip (9) in the housing plate (1).



ILLUSTRATED PARTS LIST

CONTENTS

1. Top Head Axial Adjustment
2. Top Head Power Rise and Fall
3. Pad Pressure After Top Head
4. Top Head Chipbreaker
5. Top Head Outboard Bearing
6. Bottom Head Axial Adjustment
7. Bottom Head Rise and Fall
8. Bottom Head Outboard Bearing

IMPORTANT: WHEN ORDERING SPARES ALWAYS QUOTE
MODEL AND MACHINE NUMBER

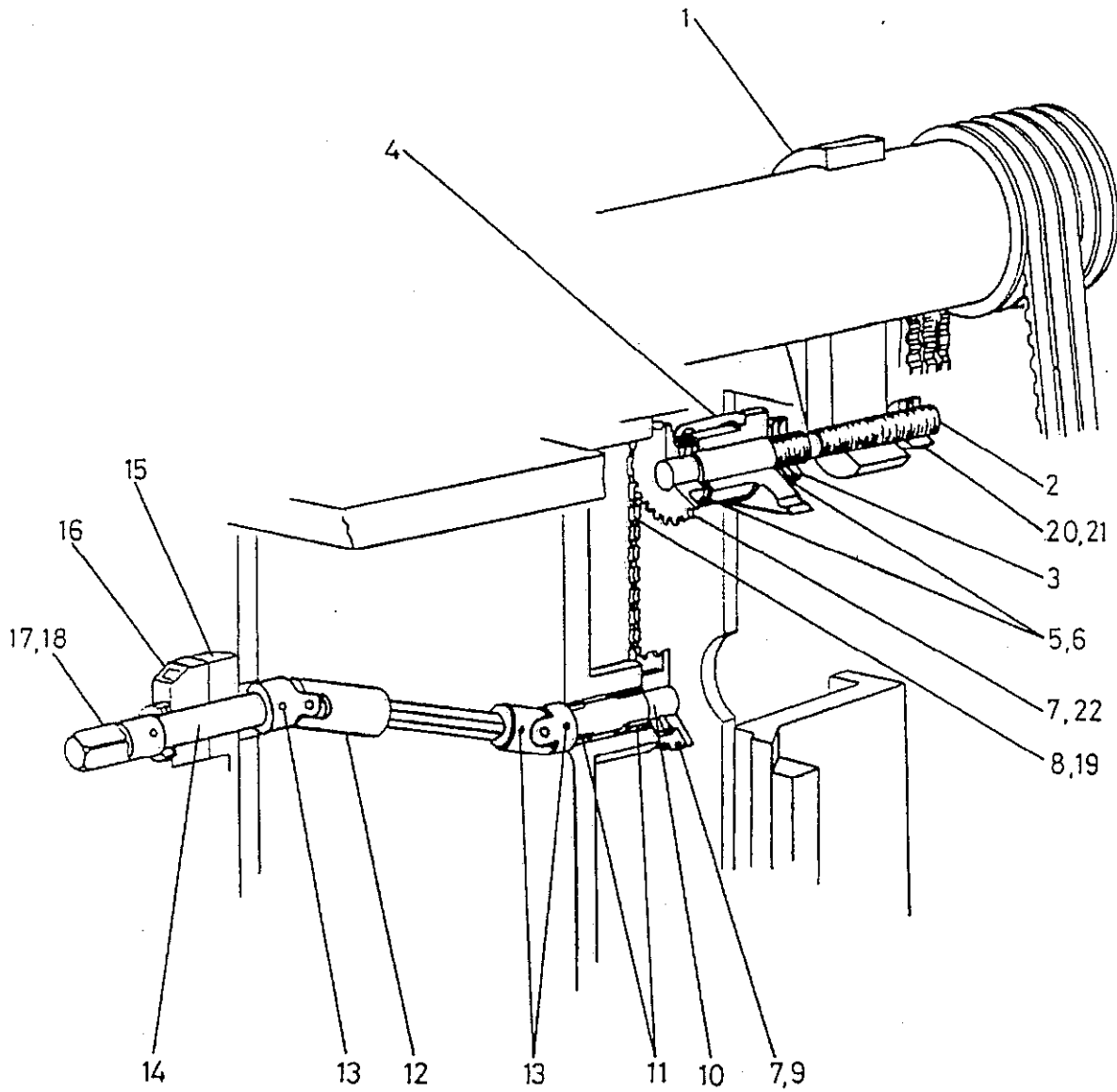

FIG 1 TOP HEAD AXIAL ADJUSTMENT



1. TOP HEAD AXIAL ADJUSTMENT

Ref No.	Description	No Off.
1.	Nut for horizontal head adjustment	1
2.	Shaft for horizontal head adjustment	1
3.	M24 x 1.5 chamfered notch nut	2
4.	Bearing bracket for horizontal head adjustment	1
5.	'INA' Thrust bearing AXK 2542	2
6.	'INA' Thrust washer AS 2542	4
7.	Sprocket for horizontal head axial adjustment	2
8.	'RENOLD' Roller chain No. 111046 12.9mm (1/2") pitch, 40 pitches	1
9.	No. 4 Taper pin	1
10.	Shaft	1
11.	20mm I/D x 25mm O/D x 20mm long bronze bush	2
12.	Universal coupling with 12mm A/F telescopic shaft	1
13.	6mm dia. x 24mm long Tension pin	1
14.	Shaft for horizontal head cross adjustment	1
15.	Bearing block	1
16.	Digital readout	1
17.	Square shaft extension	1
18.	Taper pin No.1	1
19.	Chain connector link	1
20.	Threaded collar M20 Trapezoidal	1
21.	Hexagon socket grub screw M8 x 8mm long	2
22.	6mm dia. x 40mm long Tension pin	1

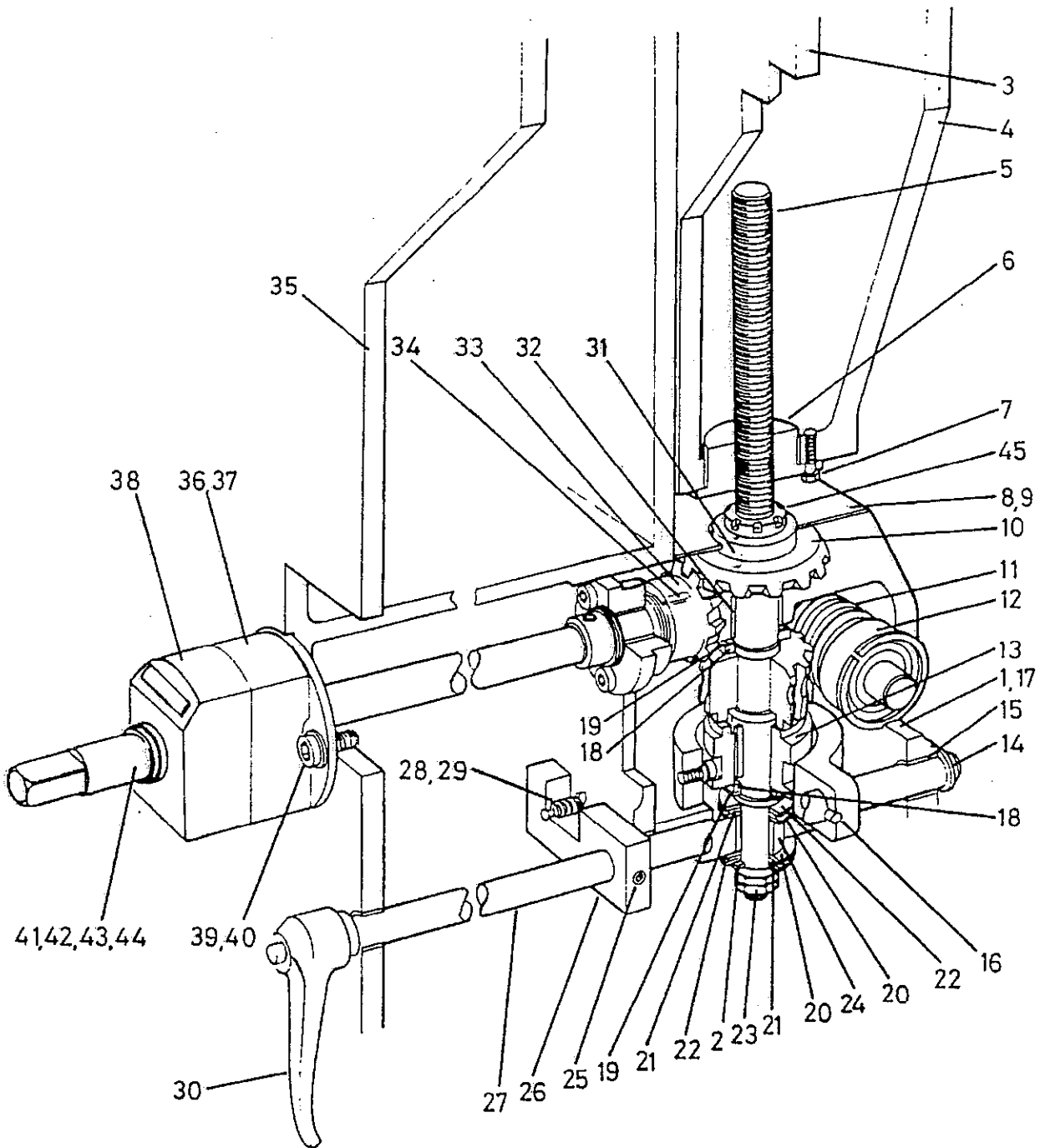

FIG 2 TOP HEAD POWER RISE AND FALL



2. TOP HEAD POWER RISE AND FALL

Ref No.	Description	No Off.
1.	Socket head capscrew M12 x 30mm long	4
2.	Plain washer M16	1
3.	Slide strip	1
4.	Top head vertical slide	1
5.	Vertical rise and fall screw	1
6.	Nut for rise and fall screw	1
7.	Hexagon head setscrew M8 x 25mm long	2
8.	Top cover	1
9.	Hexagon socket capscrew M6 x 8mm long	4
10.	Bevel gear	1
11.	Worm gear	1
12.	Bearing 'SKF' 6204 RS	2
13.	Dog clutch	1
14.	External circlip 16mm dia.	2
15.	Bronze bush 20mm O/D x 16mm I/D x 16mm long	2
16.	Tension pin 6mm dia. x 32mm long	1
17.	Gearbox/clutch housing	1
18.	Clutch spacer washer	2
19.	External circlip 30mm dia.	2
20.	Thrust washer 'INA' AS 2542	2
21.	Thrust bearing 'INA' AXK 2542	2
22.	Shaft washer 'INA' WS 2542	2
23.	Locknut M16	2
24.	Bronze bush 30mm O/D x 25mm I/D x 20mm long	1
25.	Hexagon socket grub screw M6 x 10mm long	1
26.	Clutch location arm	1
27.	Clutch adjusting shaft	1
28.	Spring for spindle lock	1
29.	Stell ball 10mm dia.	1
30.	Locking handle M10 x 25mm male	1
31.	Parallel key 8mm x 7mm x 14mm long	1
32.	Bronze bush 35mm O/D x 30mm I/D x 20mm long	1
33.	Bevel gear	1
34.	Parallel key 5mm x 5mm x 20mm long	1
35.	Main frame	1
36.	Bearing bracket	1
37.	Bronze bush 25mm O/D x 20mm I/D x 15mm long	2
38.	'SIKO' digital readout 0902E 2mm	1
39.	Hexagon socket capscrew M6 x 20mm long	2
40.	Plain washer M6	2
41.	Square end shaft extension	1
42.	Taper pin No 1	1
43. +	Compression spring	1
44.	External circlip 25mm dia.	1
45.	Notch nut M24 x 1.5mm	1

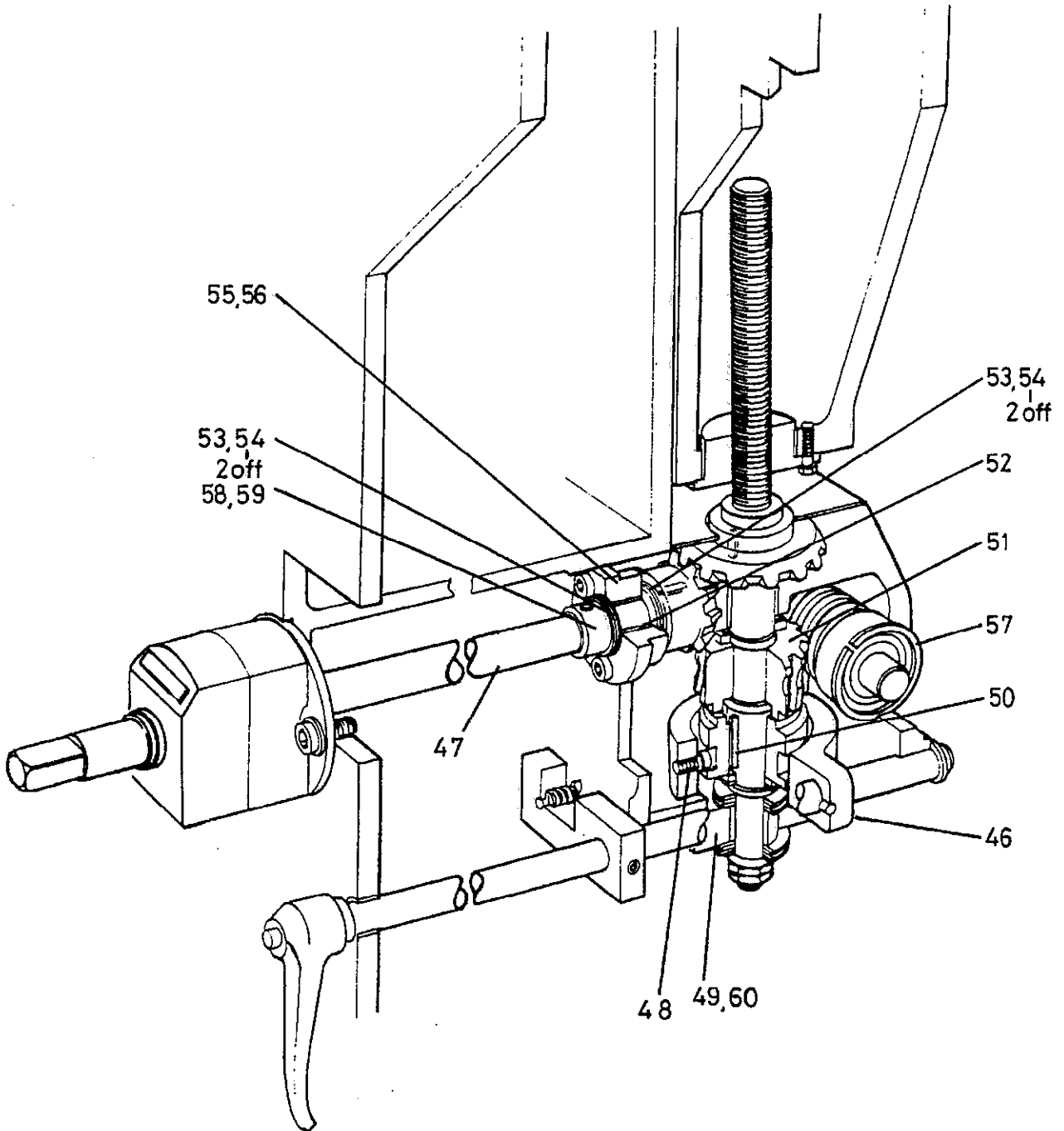

FIG 2 TOP HEAD POWER RISE AND FALL