

Wadkin

UNIVERSAL PATTERN MILLER

TYPE W. X.

All cutter information in this book refers to wood cutting only. For information on cutters suitable for cutting brass and aluminium refer to Booklet No. 765.

Wadkin Ltd., Green Lane Works, Leicester. Telephone: Leicester 0116 2769111
London Office: Brookfield House, 62-64 Brook Street, W. 1.

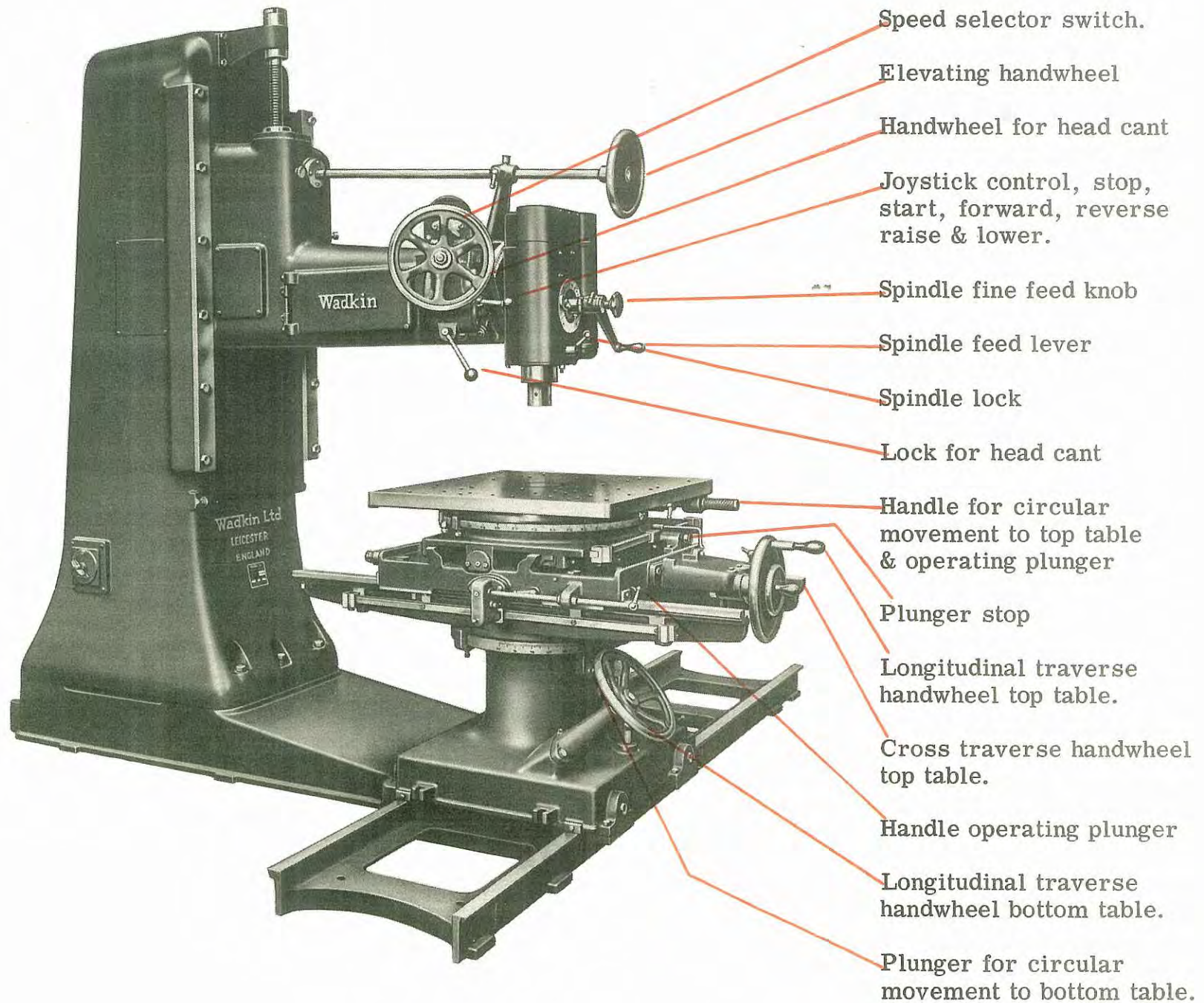

Wadkin

Principal Dimensions and Capacities

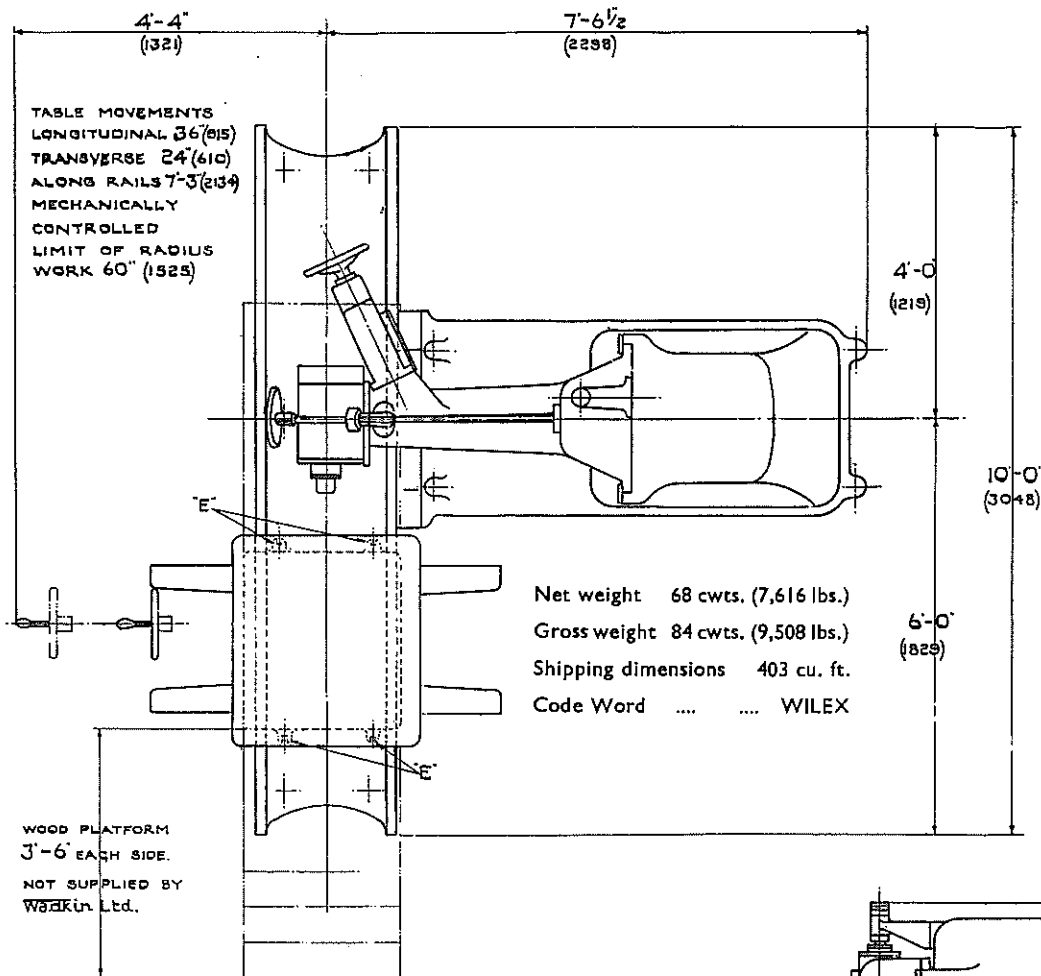

Page 3

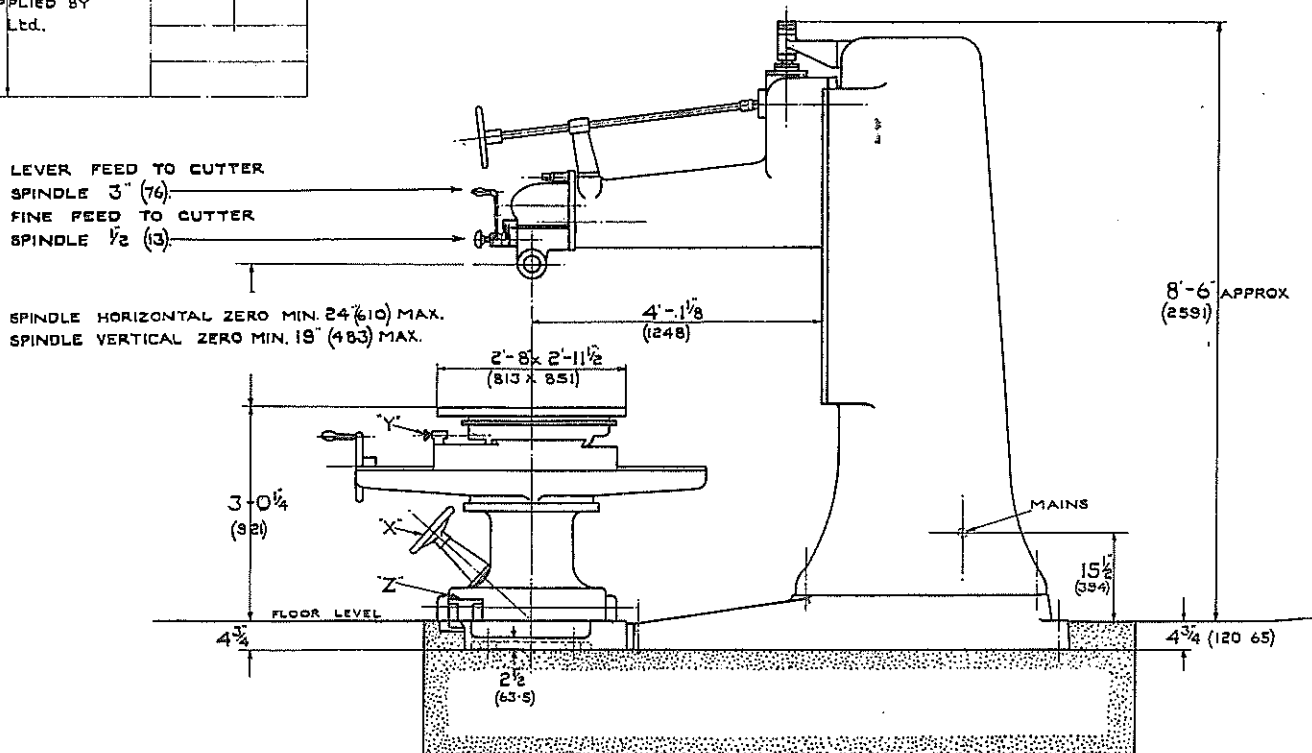

INSTALLATION

The following instructions are intended to be a step by step guide for assembling the machine and should be followed in the given sequence to obtain the alignment test limits shown in fig. 10 page 12. The instructions cover the unloading of the machine units, laying down the foundations, assembling of the machine and checking the alignments.

INSTALLATION

CHECKING

All the units and accessories received should be checked against the accompanying packing list. Wadkin Ltd. should be notified immediately of any discrepancy which may arise.

SLINGING

The Machine is despatched in five main units for easy handling and packing. When unloading or assembling, each unit must be handled carefully to avoid any damage. Figures 1, 2, 3 show the correct method of lifting the three most difficult units.

The table below indicates the weights of the various units. These particulars are intended to give the load carrying capacity of the equipment required for handling these units.

WEIGHTS	Column	Base	Arm	Rails	Table
GROSS	3570 lbs.		2870 lbs.	822 lbs.	2506 lbs.
NETT	2156 lbs.	700 lbs.	2240 lbs.	542 lbs.	2122 lbs.

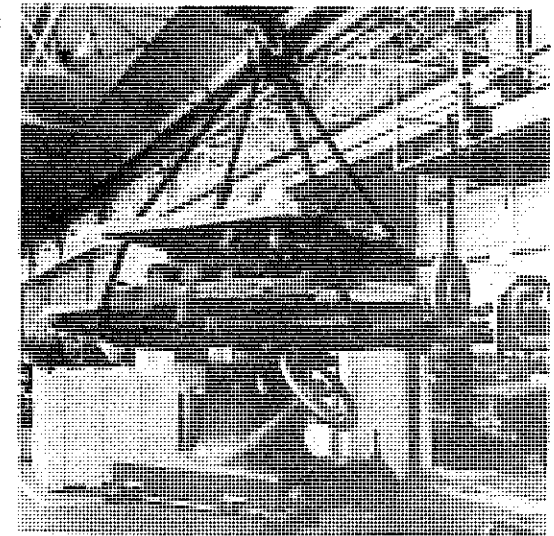
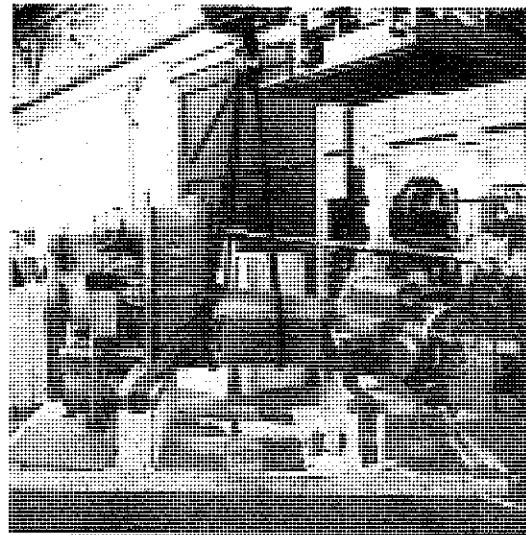
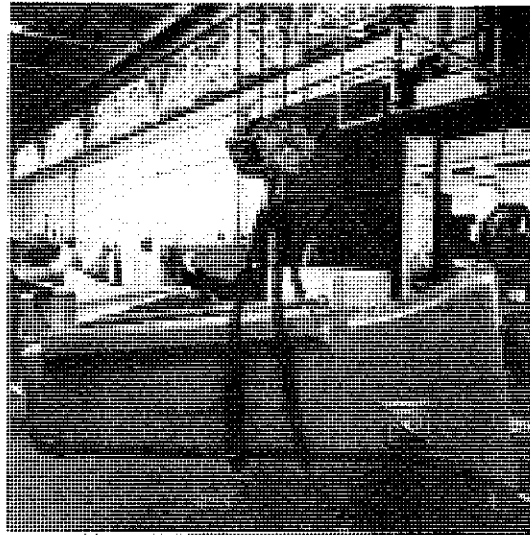

FIG. 1. Slings of the main column. FIG. 2. Slings of the arm unit. FIG. 3. Slings of the table.

CLEANING.

The machine is despatched from our works with all the bright surfaces greased to prevent rusting. This grease can be removed by applying a cloth soaked in kerosene or turpentine.

FOUNDATION.

A special concrete foundation must be prepared for this machine in accordance with the adjoining plan fig. 4. page 7. The surface of the finished foundation must be $4\frac{3}{4}$ " below the floor level, and the depth of the concrete bed must not be less than 9" as shown in fig. 4. Use 6 - $\frac{3}{4}$ " diam. x 9" long rag type foundation bolts for the rails, and 4 - 1" dia. x 12" long rag type foundation bolts for the machine base.

SETTING AND LEVELLING OF THE BASE AND THE RAILS.

Lift the base a foot or so off the ground. Insert 4 - 1" diam. x 12" long rag type foundation bolts in their four respective holes. Screw each nut and washer on so that the bolts stand level with the top face of the nut. Place the base in position on the foundation putting $\frac{1}{4}$ " thick shims under each of the four shimming pads shown in Fig. 4. The foundation bolts will now hang vertically in the four square holes cast in the concrete bed. To obtain an accurate level the following procedure should be adopted. Clean the base thoroughly. Place an accurately ground steel bar $1\frac{3}{4}$ " square x 3ft. long on the machined faces of the base. Test the level in three directions (lengthwise, across and diagonally) with an accurate spirit level placed on the top face of the square bar. The spirit level used should give a minimum reading of .0005" in 10". It will be found necessary to use additional shims of varying thickness under each of the four pads before a perfect level is obtained.

Place the 6 - 3" x 3" x $\frac{1}{4}$ " thrust plates (supplied) in position as shown in fig. 4. Position the rails on the foundation with 6 - $\frac{3}{4}$ " x 9" long rag type foundation bolts and the 6 - $\frac{5}{8}$ " x 3" long square headed levelling screws inserted. Make sure that the levelling screws locate in the dimples of the thrust plates. Adjust the height of the rails by means of the levelling screws so that the top faces of the rail bolting up pads stand level with the top faces of the base bolting up pads. Line up the zero marks scribed on the top faces of the pads. The 2 - $\frac{3}{4}$ " diam. pad bolts can then be inserted through the bolting up pads and the nuts tightened finger tight only. The rails can now be levelled in both directions by using the same spirit level and the ground square bar already used for levelling the base. It will be found necessary to adjust the levelling screws before a perfect level is obtained lengthwise and across

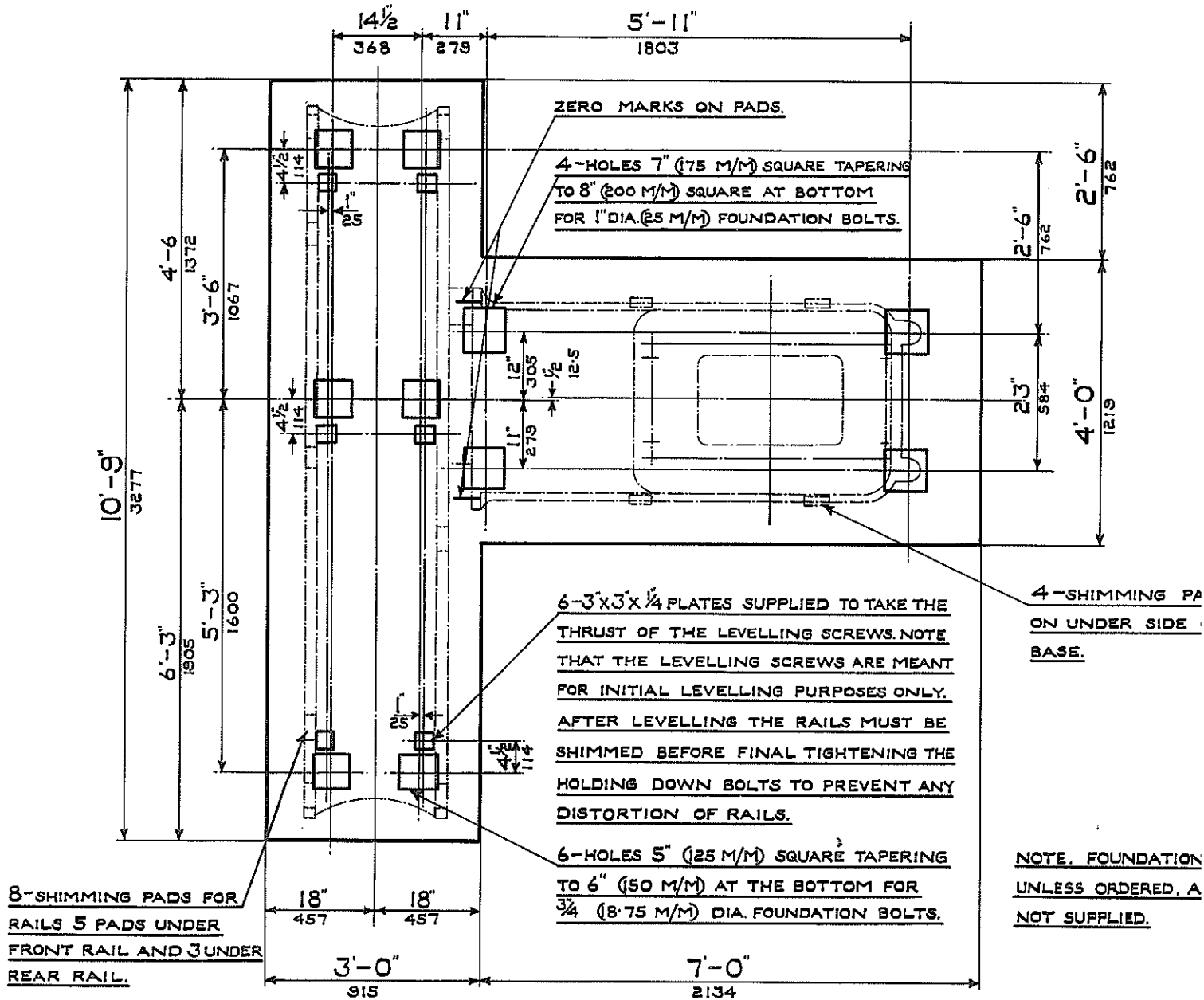

GROUT WITH LIQUID CEMENT
AFTER THE MACHINE HAS BEEN
ASSEMBLED AND WIRED.

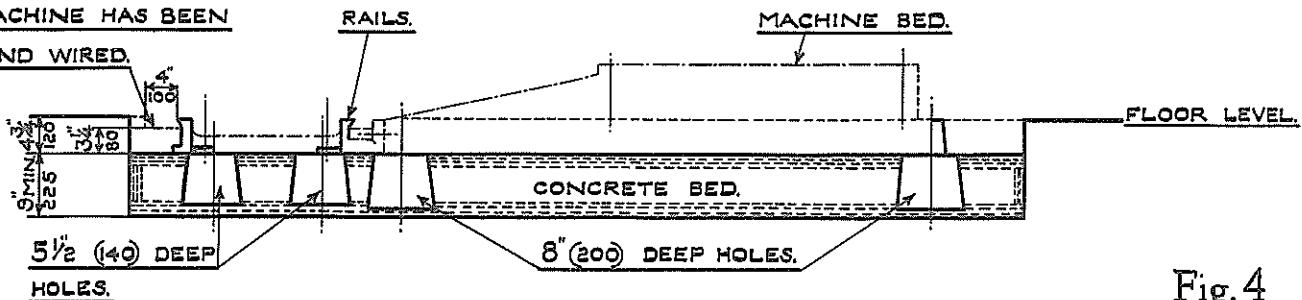

FOUNDATION PLAN FOR SEMI-AUTO PATTERN MILLER TYPE W.X.

DIMENSIONS IN INCHES AND M/M.

the rails. IT IS IMPORTANT TO NOTE THAT THE LEVELLING SCREWS ARE FOR INITIAL LEVELLING ONLY. AFTER LEVELLING, THE RAILS MUST BE SHIMMED UNDER THE EIGHT SHIMMING PADS SHOWN IN FIG. 4. Tighten the pad bolts and carefully check the level again. If required make further adjustment until final level is obtained.

Grout in the foundation bolts with a good mixture of liquid cement and allow at least 36 hours for the cement to set before tightening the foundation bolts. After the foundation bolts have been tightened the level must be re-checked. IT IS IMPORTANT THAT A CONSTANT CHECK IS KEPT ON THE LEVEL OF BOTH RAILS AND BASE.

MOUNTING THE COLUMN.

Place the column horizontally on a support as shown in Fig. 5 below. To raise the column into the vertical position use an endless rope sling 10ft. to 12ft. long. Wrap it round the column as shown in Fig. 6. Make sure that the bite of the rope sling is close to the anchor bracket.

When lifted the column will rise into the vertical position. Clean down the base and the under side of the column. Position the column on the base and insert the 4 - 1" diam. hexagon head bolts with washers. Screw down the bolts but do not tighten them. Locate the two dowel holes in the base corresponding to those in the column. Knock in the square headed dowels supplied. Now the fixing bolts can be tightened down. If the bolts are tightened down first it will be impossible to locate dowels afterwards.

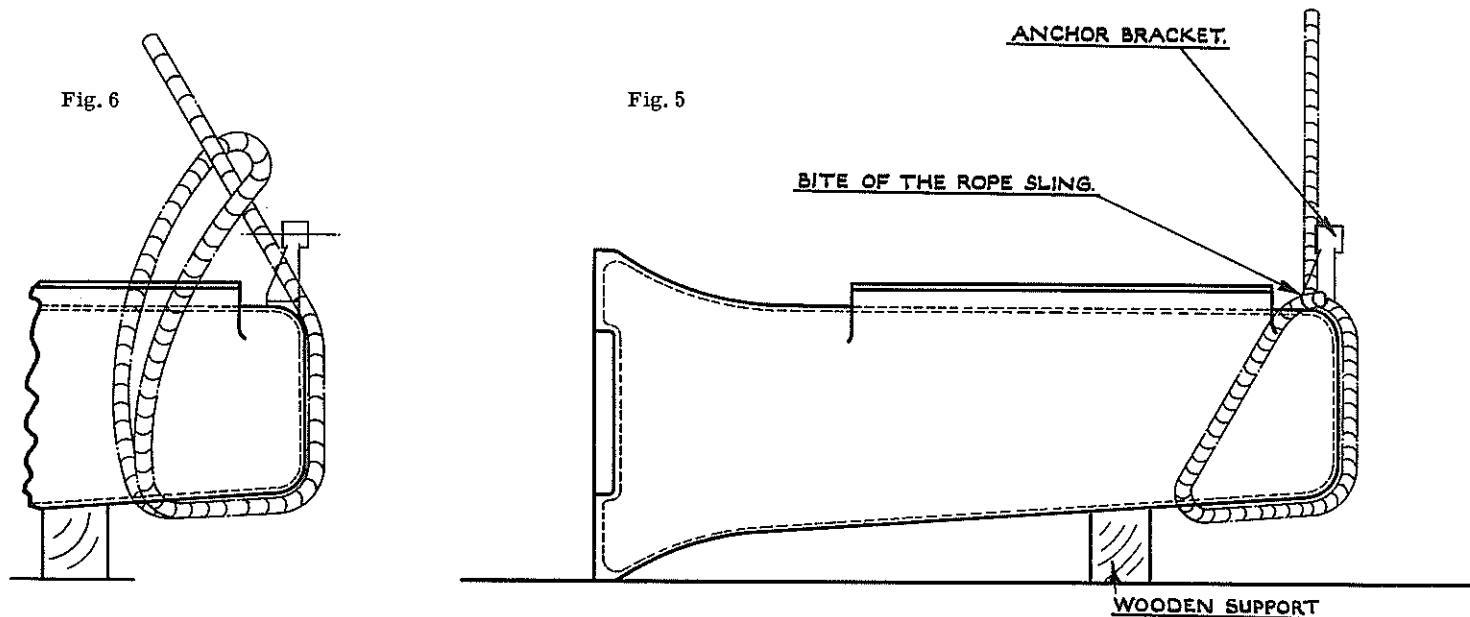

MOUNTING THE ARM ON THE COLUMN.

Sling the arm as shown in fig. 2. Page 5. CLEAN AND OIL THE COLUMN AND ARM SLIDES. Bring the arm into position in the column slides. CLEAN AND OIL GIB STRIP A and slide it in position as shown in fig. 7 below. When the gib strip is in correct position the line - O on the gib strip must be in line with the mark - O on the front of the arm slides, as shown in fig. 7 Lock the gib strip in this position using the two lock nuts B and C (fig. 7). CLEAN AND OIL THE KEEP STRIPS D AND E. Bolt the keep strips in position using $7/8$ " diam. $2\frac{1}{4}$ " long hexagon head screws supplied. Make sure that the correct strip is bolted to the correct side of the column. Keep the arm supported by means of the sling. Remove the collar F from the elevating screw S by knocking out the taper pin. Hold the screw vertical and allow it to pass through the anchor bracket G with the bronze washer H between the anchor bracket G and locknuts J, through the collar F (re-inserted) down into the brass nut K in the arm. Screw down until the taper pin can be engaged through the collar F with the brass washer H trapped between the anchor bracket G and locknuts J. Tighten the locknuts sufficiently to prevent the screw from rotating when the arm is elevated by the handwheel W (final adjustment of these locknuts will have to be made after erection). Ensure that the elevating screw has been fully engaged in the nut K before removing the rope sling. It may be found necessary to raise the arm to obtain complete engagement of the screw in the nut. It is most dangerous to allow the elevating screw to carry the full load of the arm if only a few threads of the screw are in engagement in the arm nut.

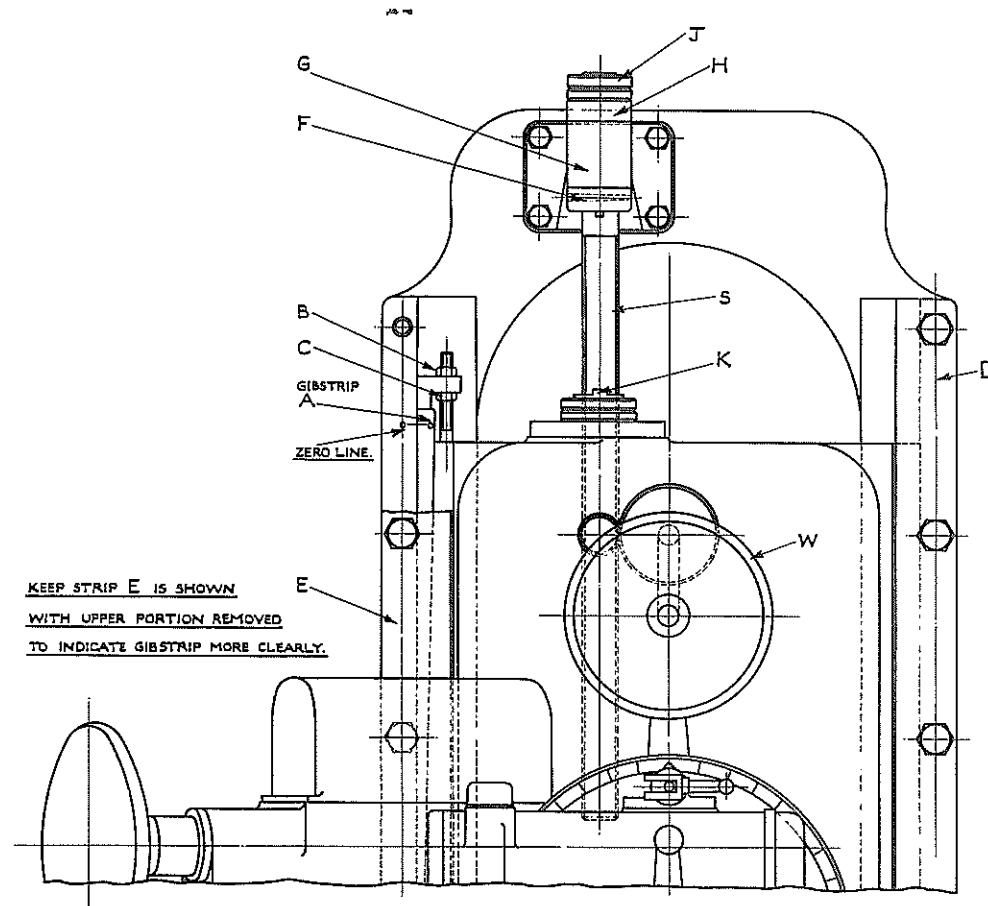

Fig. 7

MOUNTING THE TABLE ON THE RAILS.

Remove the two lip plates L. L. shown in fig. 8. page 11. Release the lock P. Lift the table as shown in fig. 3. page 5. Place the table approximately in a central position on the rails and pull the complete table unit towards the front, so that the rear lip plates press hard against the underside of the rails. Replace the front two lip plates L. L. and bolt them up ensuring a clearance of .002" between the lip plates and the underside of the rails.

CARRY OUT THE ALIGNMENT TESTS WORKING TO THE LIMITS SHOWN IN CHART FIG. 10 ON PAGE 12.

When the machine leaves our works the table frame plunger bracket Q in fig. 8 is simply bolted in position. After the above procedure has been carried out and alignment found to be within the limits, the correct position for the bracket Q must be found and the bracket dowed as follows:-

Swing the cutter spindle to the vertical position. Fit the centre finder into the cutter spindle. Lower the arm by hand wheel W shown in fig. 7 on page 9 until the point of the centre finder is just above the table surface. Drop plunger M of the plunger bracket Q (fig. 8) and loosen the bolts holding the bracket Q. Adjust the table by handwheel R until the plunger U is engaged in centre stop T. Now move the complete table unit by handwheel X so that the plunger M (already dropped) may locate in the taper hole in the front rail. Give the table unit slight adjustments until the centre finder registers with the line on the table top. Lock the table with locking lever P in this position, bolt the bracket Q in this position. Drill and ream through the existing dowel holes Z. Z. in bracket Q and insert the supplied dowels.

The machine can now be grouted as shown in fig. 4 page 7 with liquid cement.

Allow at least 36 hours for the cement to set.

BEFORE PUTTING THE MACHINE INTO OPERATION THE LEVEL AND ALIGNMENT LIMITS MUST BE RECHECKED TO MAKE SURE THAT THE MACHINE HAS BEEN CORRECTLY ERECTED.

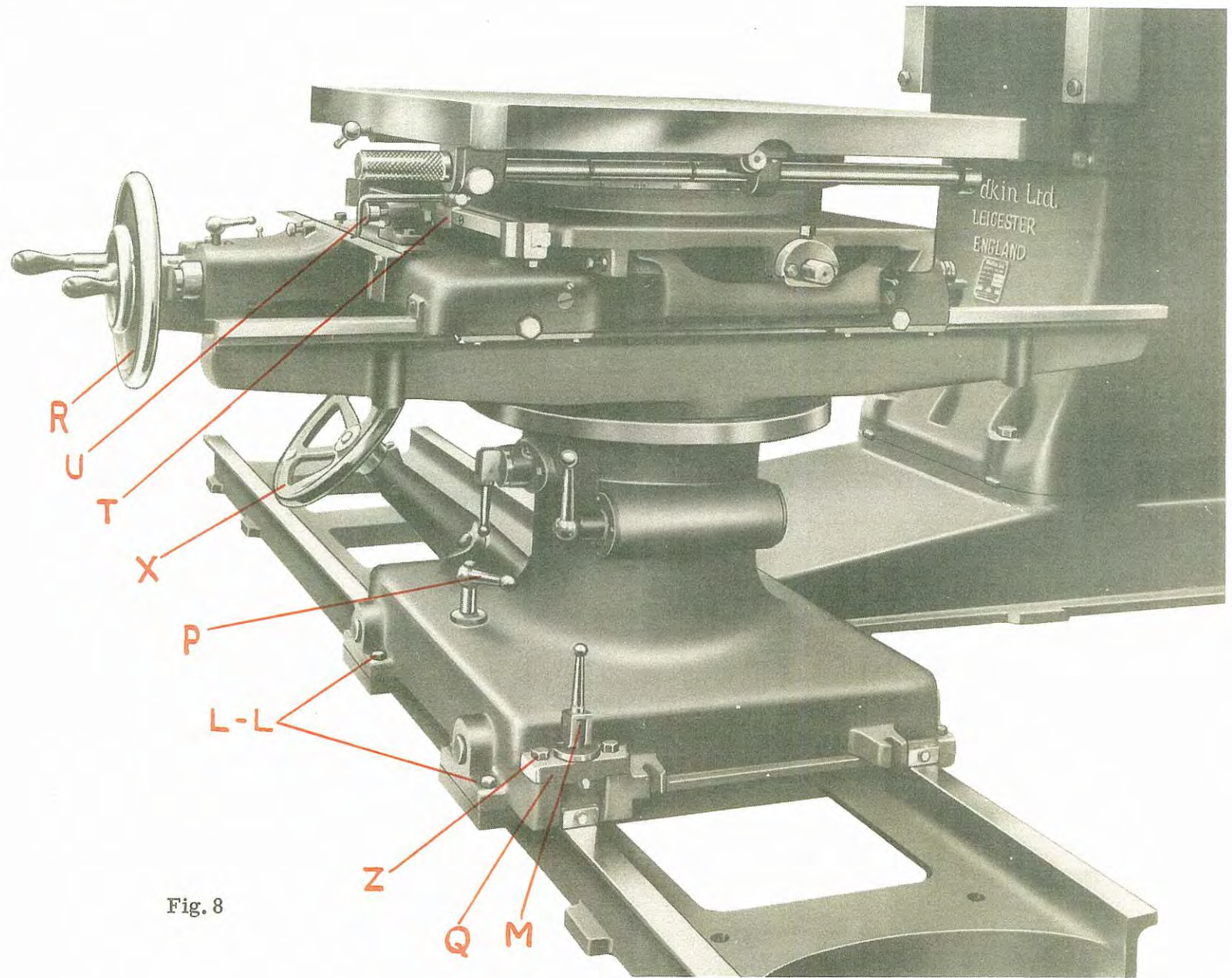
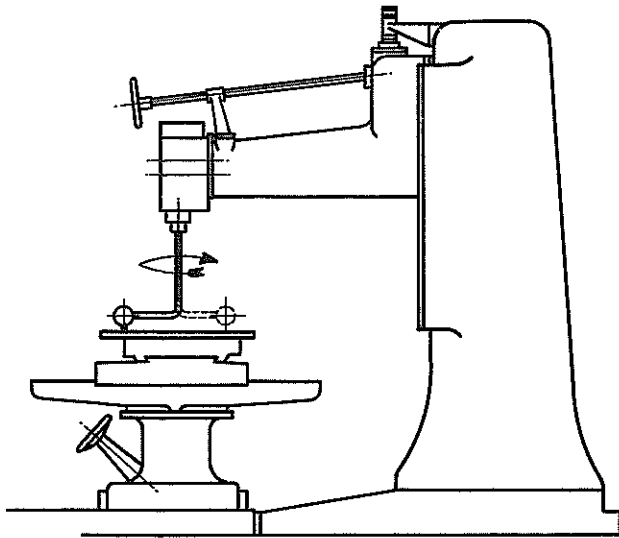
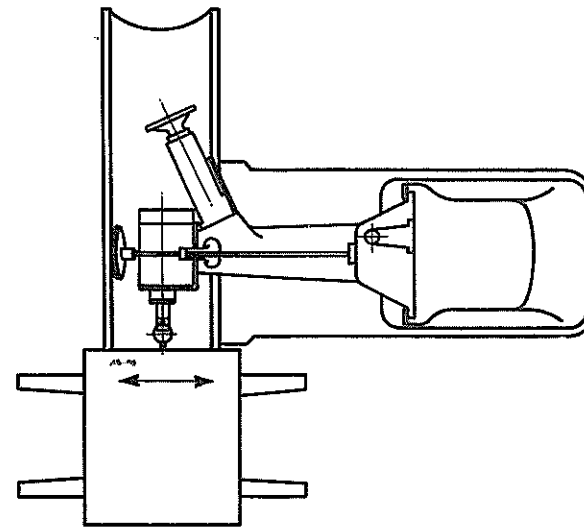

Fig. 8

ALIGNMENT TEST LIMITS.



Test for squareness of spindle in vertical position to table. Tolerance $\pm .0025''$ on 20" dia. circle.



Test for squareness of table edges in all four 90° positions of table. (Note:- This test is carried out firstly, by rotating top table only and secondly by rotating the table unit from the lower barrel). Tolerance $\pm .001''$ per foot.

Fig. 10.

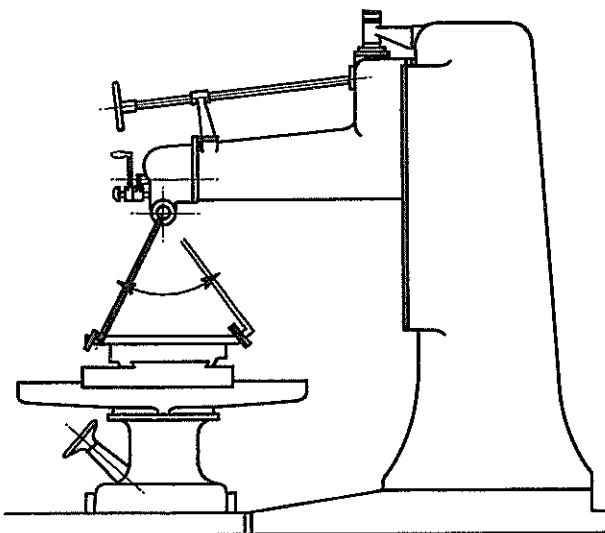

Test for squareness of spindle to table edge. This is checked on all four sides by both radial movements of the table as in test above. Tolerance $\pm .002''$ on length of table.

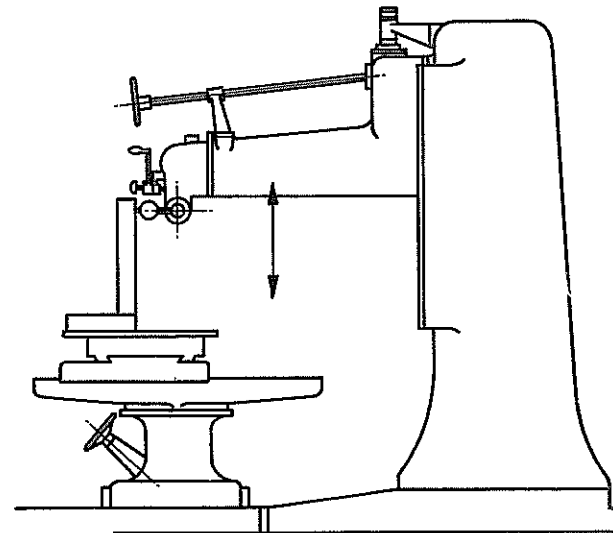

Test for squareness of vertical travel of cutter head to table from side. Tolerance $\pm .0015''$ per foot.

ALIGNMENT TEST LIMITS.

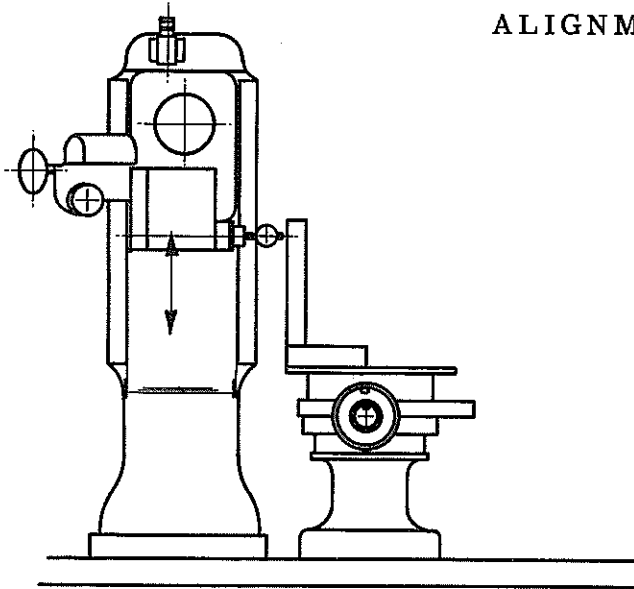

Test for squareness of vertical travel of cutter head to table from front.
Tolerance $\pm .0015''$ per foot.

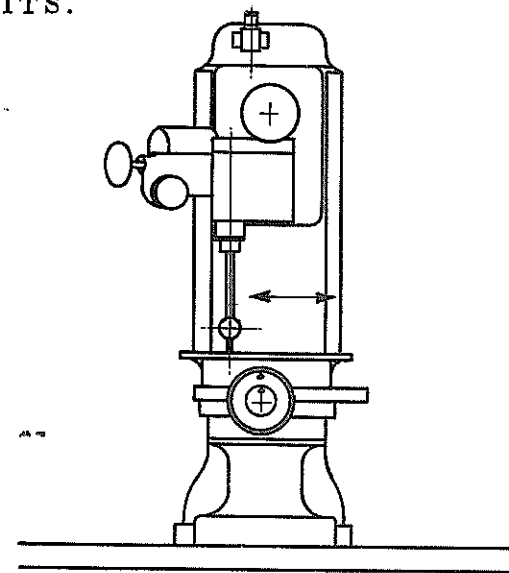

Checking parallelism of longitudinal table travel with spindle.
Tolerance $\pm .001''$ per foot.

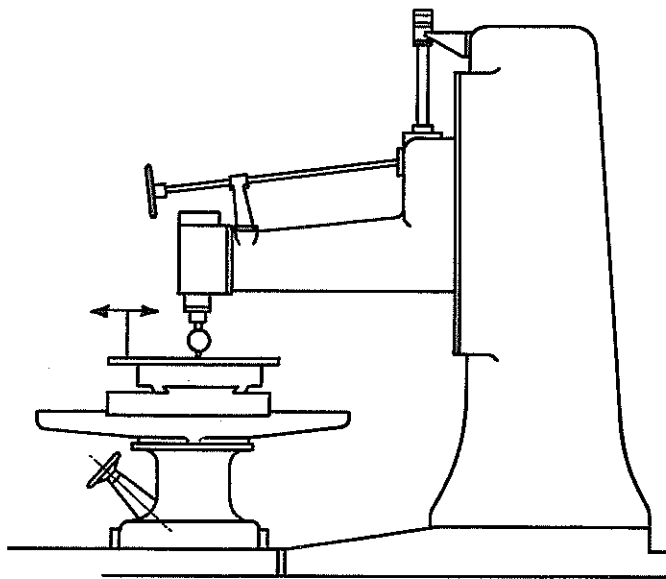

Checking parallelism of transverse table travel with spindle.
Tolerance $\pm .001''$ per foot.

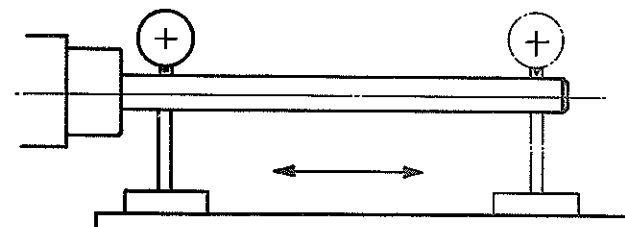

Test for parallelism of spindle in horizontal position to table.
Tolerance $\pm .0015''$ on 10" long test bar.

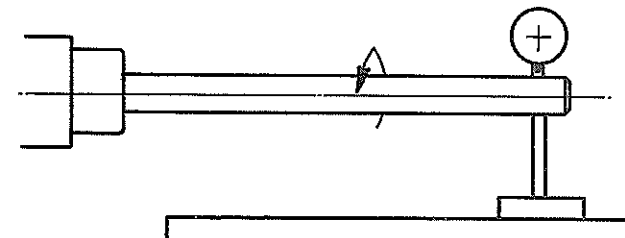

Test of rotation of spindle at end of 10" long test bar. Tolerance $\pm .001''$.

LUBRICATION

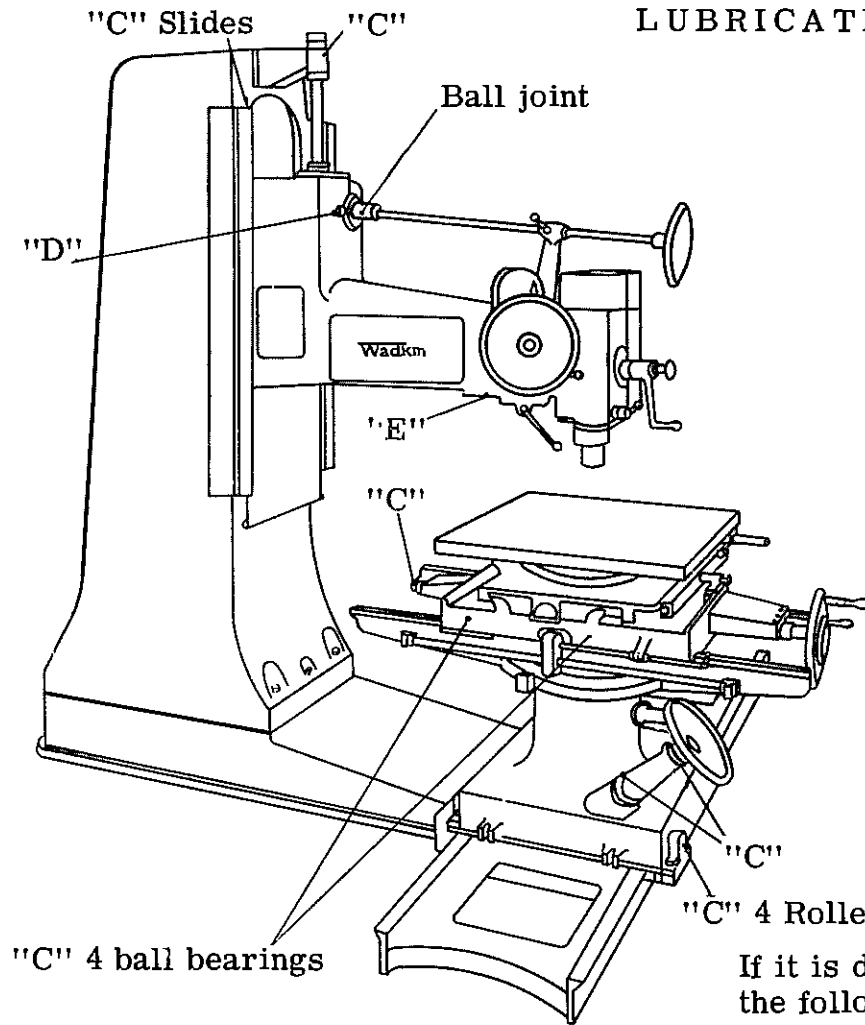

"A" Give 4 depressions of grease gun every 3 months using Wadkin grease Grade L. 6.

"B" Give 2 depressions of grease gun twice weekly using Wadkin grease Grade L. 6.

"C" Fill oiler up daily using Wadkin oil Grade L. 4 or twice weekly if machine is not in daily use.

"D" Remove plug "O" & cover "E" and grease worm gears every 6 months using Wadkin grease L. 6.

"F" Slide rubber cover away & grease ball joints every 6 months using Wadkin grease Grade L. 6.

If it is desired to use lubricants other than Wadkin the following equivalents are listed below:

Wadkin High-speed Spindle Oil, Grade L. 1	Vacuum Oil Co. Gargoyle DTE Oil (light special) Shell-Mex. Shell Vitrea Oil 27. Caltex Lubricants: Regal Oil B (R & O)
Wadkin Machine Oil, Grade L. 4.	Vacuum Oil Co. Gargoyle Vactra Oil (heavy medium) Shell-Mex. Shell Vitrea Oil 33. Caltex Lubricants: Caltex Aleph Oil.
Wadkin Ball Bearing Grease, Grade L. 6.	Vacuum Oil Co. Gargoyle Grease BRB. 3. Shell-Mex. Shell Nerita Grease 3. Caltex Lubricants: Regal Starfak No. 2 Grease.

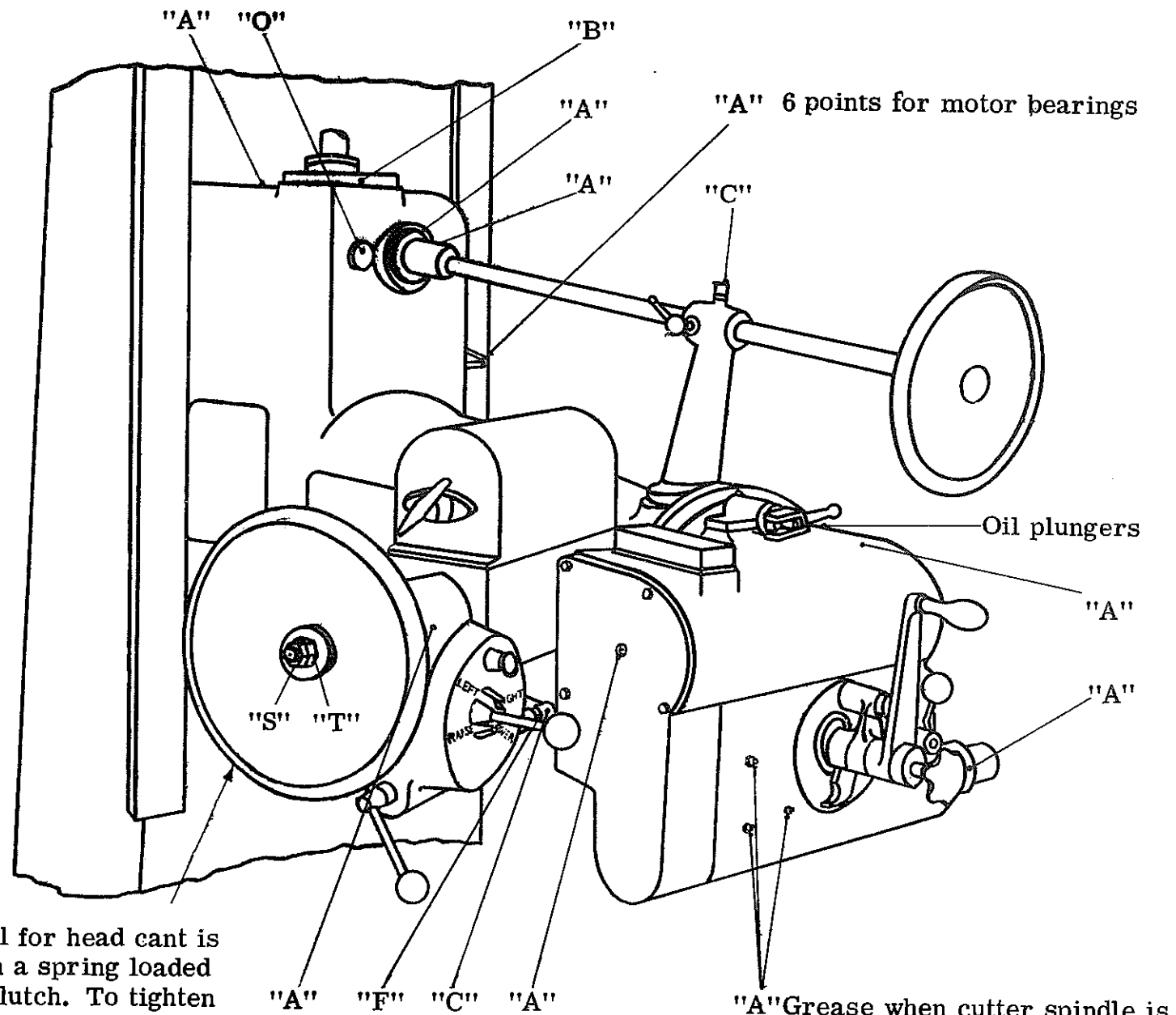

Handwheel for head cant is fitted with a spring loaded slipping clutch. To tighten slacken nut "S" and tighten nut "T", lock nut "S" against nut "T".

"A" Grease when cutter spindle is in extreme back position.

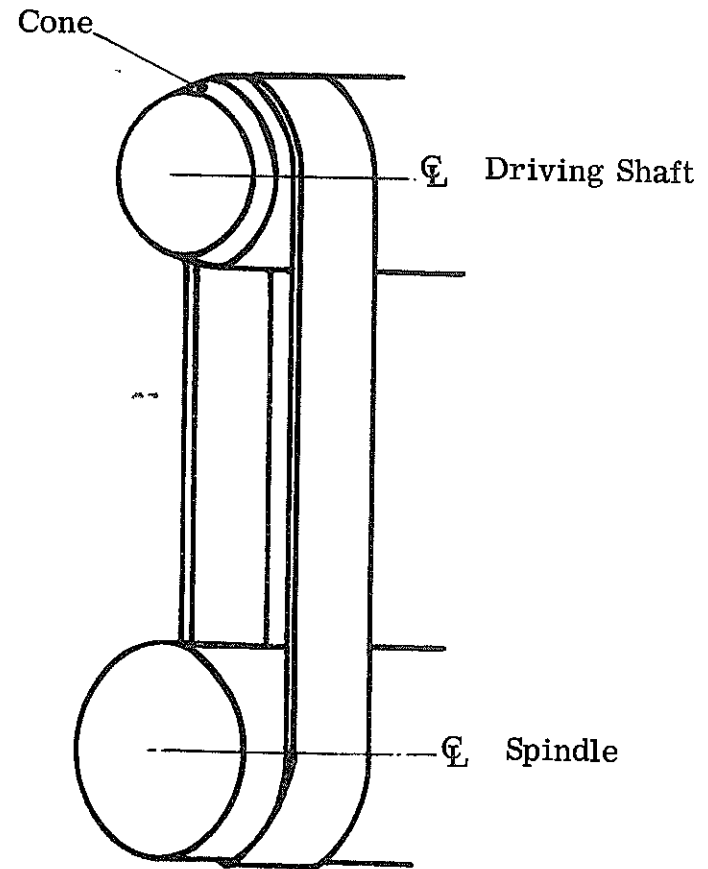
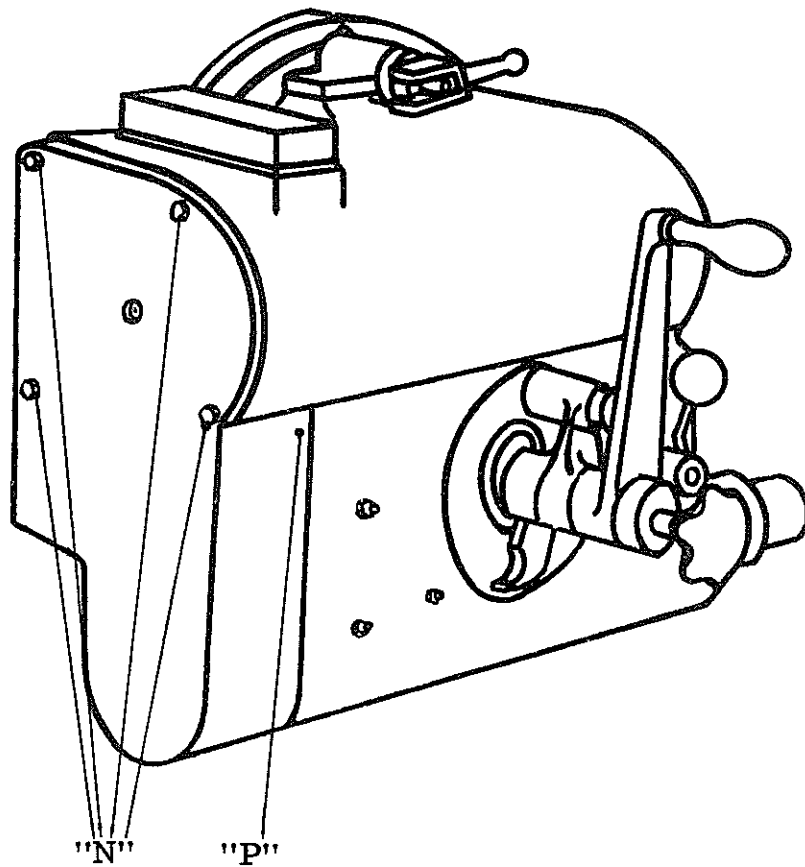

TO FIT NEW BELT ON SPINDLE DRIVE.

Remove four hexagon head screws "N" and one screw "P" and cover complete with sheet iron guard. Place belt on leading edge of spindle pulley and by rotating driving shaft work belt up the cone onto the driving pulley. Run the belt to check that it tracks evenly on the pulleys, when running in both directions on lowest speed.

These driving belts are manufactured for Wadkin Ltd. by Stephen Belting Co. Ltd. and are of their patented nylon construction. Replacement belts should be ordered from Wadkin Ltd. quoting Part No. WP. 788 and also the number of the machine.

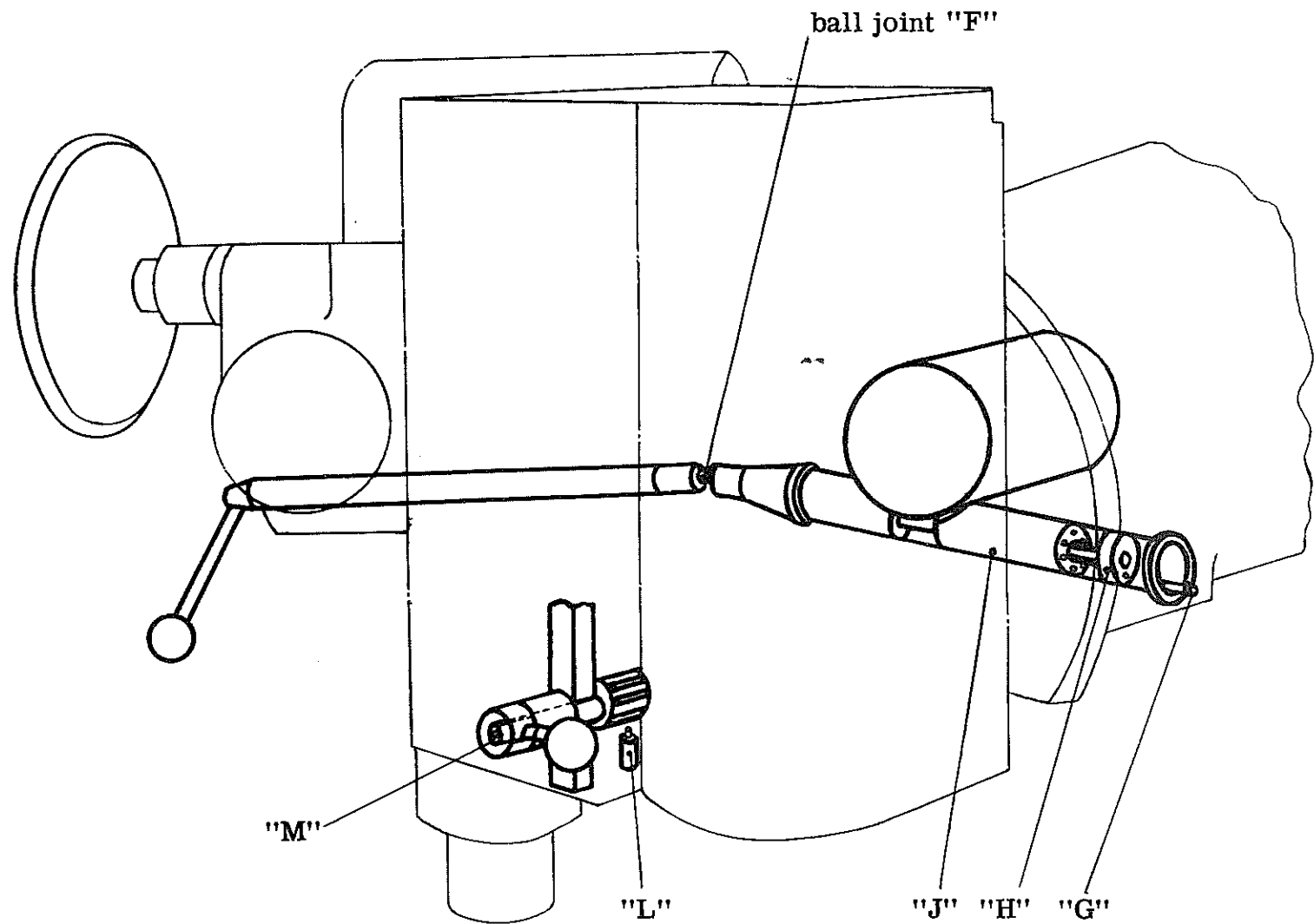

TO ADJUST LOCKING MECHANISM.

To adjust spindle lock. Remove pipscrew "L" and turn locking stud "M" by means of screw driver slot, until pipscrew can be engaged in next slot.

To adjust head canting lock. Remove screw "G" and turn nut "H" until screw can be engaged in next tapping hole in bush "J".

Lock for bottom table swivel is similar to the canting lock and the procedure to adjust is identical.

BALL BEARING LIST

POSITION ON MACHINE	MAKERS NO.	QUANTITY	BORE DIA.	OUTSIDE DIA.	THICK-NESS
Cutter Spindle (cutter end)	R & M. LDJT. 50 (special limits)	1	50 mm	90 mm	1. 3/16"
Cutter Spindle (rear end)	SKF. 1208. F.	1	40 mm	80 mm	18 mm
Driving Sleeve	SKF. 6209.	2	45 mm	85 mm	19 mm
Rotor Spindle (pulley end)	SKF. 2207. F.	1	35 mm	72 mm	23 mm
Rotor Spindle (rear end)	SKF. RLS. 10.	1	1 $\frac{1}{4}$ "	2 $\frac{3}{4}$ "	11/16"
Worm Shaft (head cant)	SKF. RLS. 8.	1	1"	2 $\frac{1}{4}$ "	5/8"
Worm Wheel (raise & fall)	SKF. O. 20.	1	2 $\frac{1}{2}$ "	3. 11/16"	1"
Worm Shaft (inner)	R&M. LJT. 2 $\frac{1}{4}$ "	1	2 $\frac{1}{4}$ "	4 $\frac{1}{2}$ "	7/8"
Worm Shaft (outer)	R&M. LJT. 1. 3/8"	1	1. 3/8"	3"	11/16"
Table Slides	SKF. RLS. 6.	4	3/4"	1. 7/8"	9/16"
Table Body	SKF. VM. 9.	1	1. 1/8"	2. 1/8"	7/8"
Table Body	SKF. VMU. 9.	1	1 $\frac{1}{2}$ "	2. 3/8"	5/16"
Drive Motor B204 (drive end and non drive end)	HOFF. 330.	2	30 mm	72 mm	19 mm
Frequency Changer MZ4120 (drive end)	HOFF. MS. 12.	1	1 $\frac{1}{4}$ "	3. 1/8"	7/8"
Frequency Changer MZ4120 (non drive end)	HOFF. RMS. 12 $\frac{1}{2}$.	1	1. 3/8"	3 $\frac{1}{2}$ "	7/8"
Raise & Lower Motor KVZ2615 (drive end and non drive end)	HOFF. MS. 8.	2	3/4"	2"	11/16"

If it is found necessary to replace a cutter spindle bearing run the spindle at lowest speed for 2 hours and then 2 hours on each consecutive speed in turn i. e. for 12 hours before using machine.

REVOLUBLE HEAD ATTACHMENT (FOR USES SEE PAGE 28).

Grub Screw to lock gear in position.

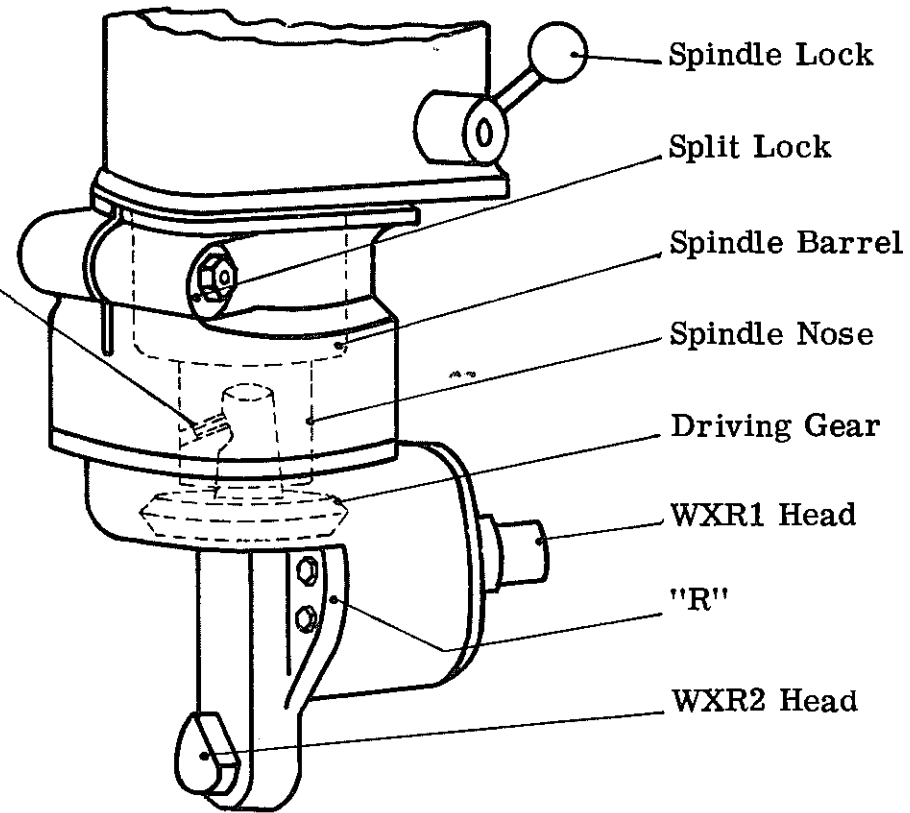

Speeds when Revoluble Heads are used :

Main Cutter Spindle	Revoluble Heads WXR1 & WXR2
4200 RPM	5300 RPM
3000 RPM	3780 RPM
2100 RPM	2650 RPM

TO FIT WXR1 REVOLUBLE HEAD.

With headstock in horizontal position and cutter spindle in extreme back position, lock driving gear in spindle nose, and smear gear teeth with Wadkin grease Grade L. 6, pass revoluble head over spindle barrel and locate on dowel pin, fit two hexagon nuts and washers and lock up tight. To mesh gears correctly, wind cutter spindle forward by means of fine feed knob until gears run freely and with a very small amount of backlash, engage spindle lock and tighten split lock onto spindle barrel.

TO FIT WXR2 REVOLUBLE HEAD,

Remove cover plate from WXR1 head, pass WXR2 head over the four studs and carefully engaging the driving tongue, replace nuts and washers and lock up tight. Give two depressions of oil gun to nipple "R", if in continuous use give two depressions daily, use Wadkin oil Grade L. 1.

NOTE:- After removing WXR2 head it is important to replace cover plate to protect head from dirt.

ELECTRICAL INSTALLATION INSTRUCTIONS

INSTALLING THE MACHINE.

The whole of the cabling between the motorised headstock, the frequency changer and the control gear is carried out by Wadkin Ltd., however it is necessary to disconnect the cables at the isolating switch for transit purposes. To put the machine into service it is necessary to remake the broken connections and bring the line cables to the isolating switch, proceeding as follows:

1) Use 15-amp. cables for connecting the machine to a 400 volts, 3 phase, 50 cycle alternating current supply. These should be carried in steel conduit. The conduit should be secured to the machine by means of locknuts at the point of entry shown in Fig. 1.

2) Connect the machine solidly to earth.

3) Having ensured that the lubricating instructions have been carried out, close the isolating switch. Select the spindle speed by means of selector switch and move the joy stick control switch to the appropriate position required. Ensure that the direction of rotation is correct before putting the machine into service. To reverse rotation interchange supply cables L1 and L3.

FAILURE TO START.

- 1) The supply is not available at the machine.
- 2) Main switch has not been closed.
- 3) The stop button has been left locked off.
- 4) The fuses either at the machine or at your distribution board have not been fitted or have blown.
- 5) Imperfect connection causing faulty contact. Check re-connections and if necessary at other points.

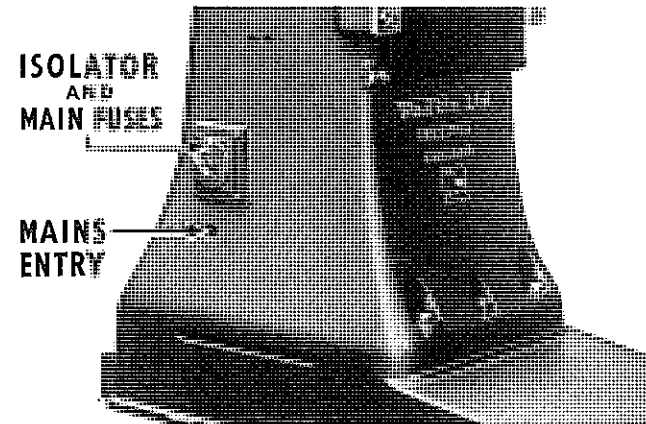
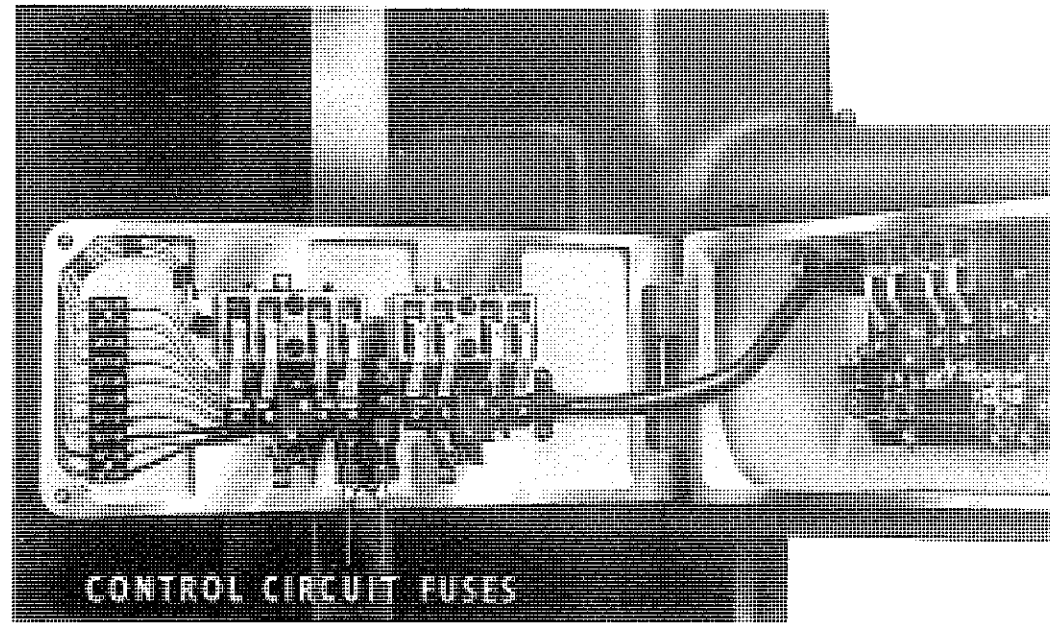

Fig. 1.

SHUT DOWN DURING OPERATION OR FAILURE TO RE-START.

Main fuses or control circuit fuses have blown. The main fuses are fitted at the isolating switch and the control circuit fuses are fitted in the main control compartment as below:-



ELECTRICAL MAINTENANCE.

The machine does not require regular electrical maintenance apart from blowing down motors and checking earth connection. Control gear etc. should not be opened up unless a fault occurs which will probably be a rare occurrence. Do not file switchgear or rotary switch contacts and do not change them because they look burnt unless they are definitely faulting.

OVERLOAD.

Should the machine stop due to overload, wait for a short time to allow the heater coils to cool and then start in the usual manner. The overloads are set at these Works at 'auto' for automatic reset after tripping. If set at 'hand' the plunger on the overload assembly should be depressed to reset.

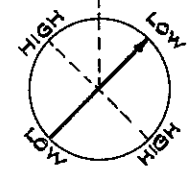
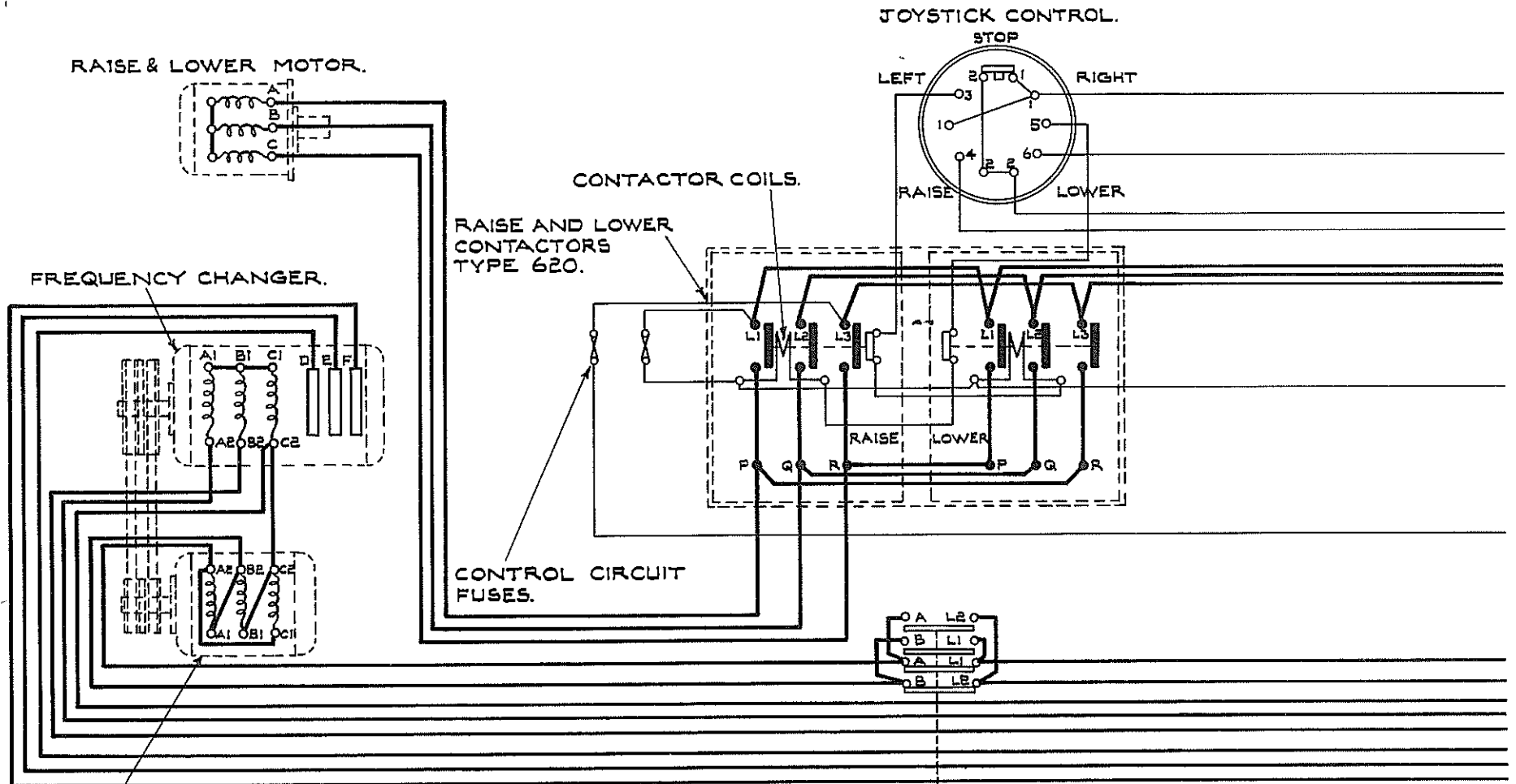

HIGH/LOW RANGE SWITCH.

'LOW' CONNECTS L1 TO A
L2 TO B.

'HIGH' CONNECTS L1 TO B
L2 TO A.

DIAGRAM OF CONNECTIONS D.569/3

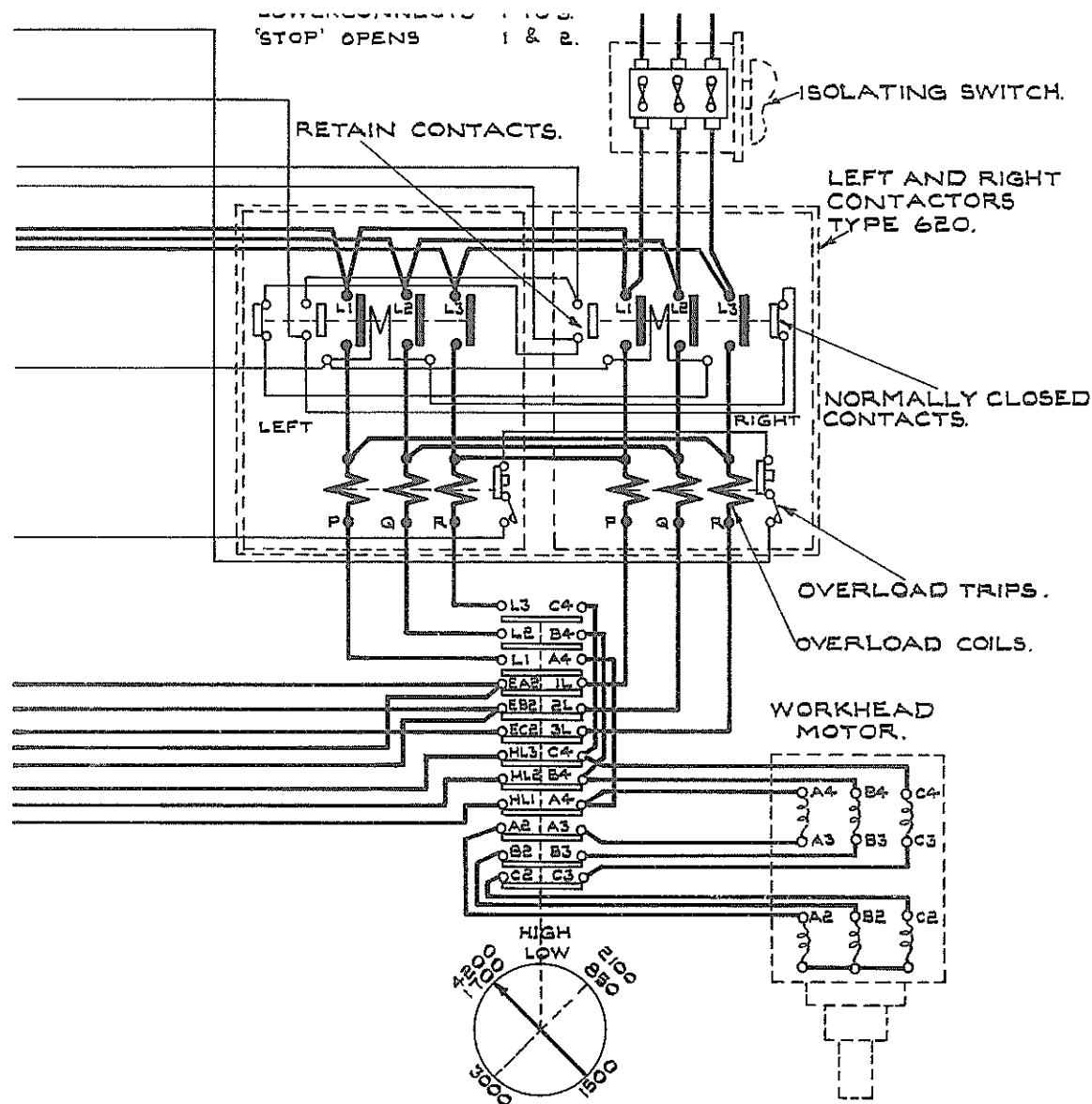

SPEED SELECTOR SWITCH.

- '1500' CONNECTS L1 TO A3, L2 TO C3, L3 TO B3
A4 TO A2, B4 TO B2, C4 TO C2.
- '3000' CONNECTS L1 TO A4, L2 TO B4, L3 TO C4
A3 TO A2, B3 TO B2, C3 TO C2.
- '1700/4200' CONNECTS HL1 TO A4, HL2 TO B4, HL3 TO C4
A3 TO A2, B3 TO B2, C3 TO C2
EA2 TO 1L, EB2 TO 2L, EC2 TO 3L.
- '850/2100' CONNECTS HL1 TO A3, HL2 TO C3, HL3 TO B3
A4 TO A2, B4 TO B2, C4 TO C2
EA2 TO 1L, EB2 TO 2L, EC2 TO 3L.

DEVELOPED DIAGRAMS OF CONTROL SWITCHES.

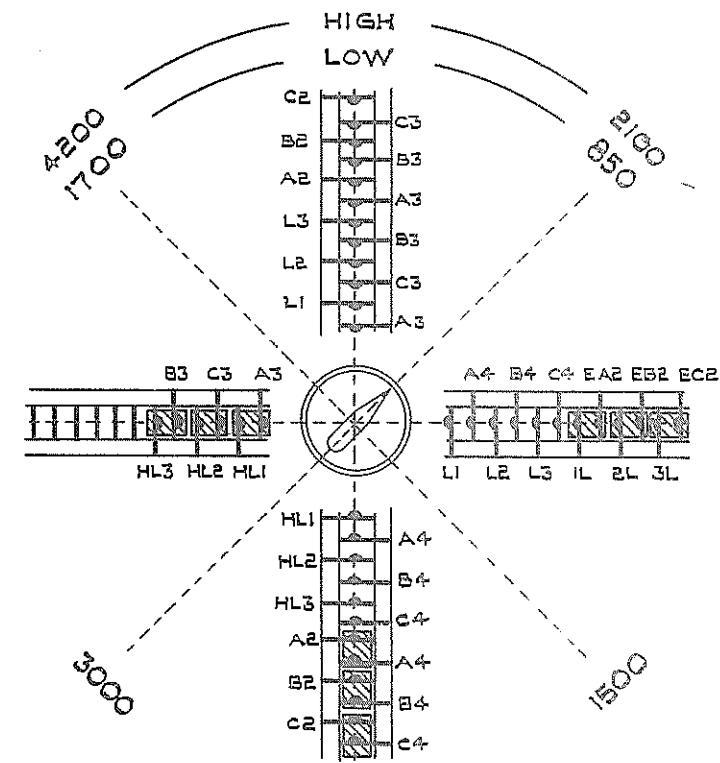

SPEED SELECTOR SWITCH.

— FIXED CONTACTS.
 ▨ MOVING CONTACTS.

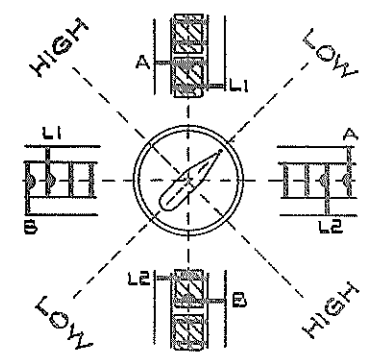

HIGH/LOW RANGE SWITCH.

'RIGHT' CONNECTS 2 TO 4.
 'LEFT' CONNECTS 2 TO 6.
 'RAISE' CONNECTS 1 TO 5.
 'LOWER' CONNECTS 1 TO 3.
 'STOP' OPENS 1 & 2.

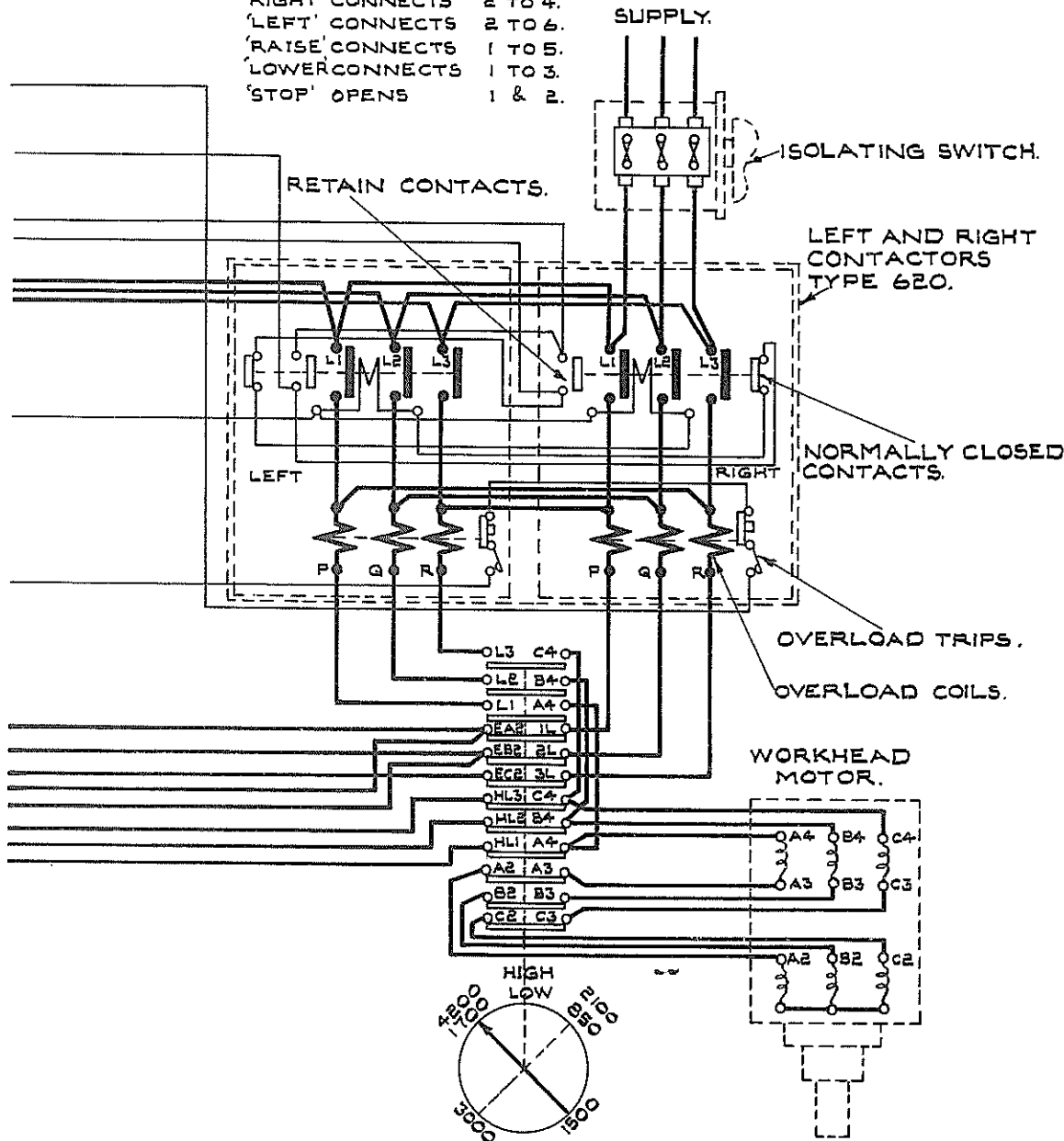

SPEED SELECTOR SWITCH.

'1500' CONNECTS L1 TO A3, L2 TO C3, L3 TO B3
 A4 TO A2, B4 TO B2, C4 TO C2.
 '3000' CONNECTS L1 TO A4, L2 TO B4, L3 TO C4
 A3 TO A2, B3 TO B2, C3 TO C2.
 '1700/4200' CONNECTS HL1 TO A4, HL2 TO B4, HL3 TO C4
 A3 TO A2, B3 TO B2, C3 TO C2

DEVELOPED DIAGRAMS OF CONTROL SWITCHES.

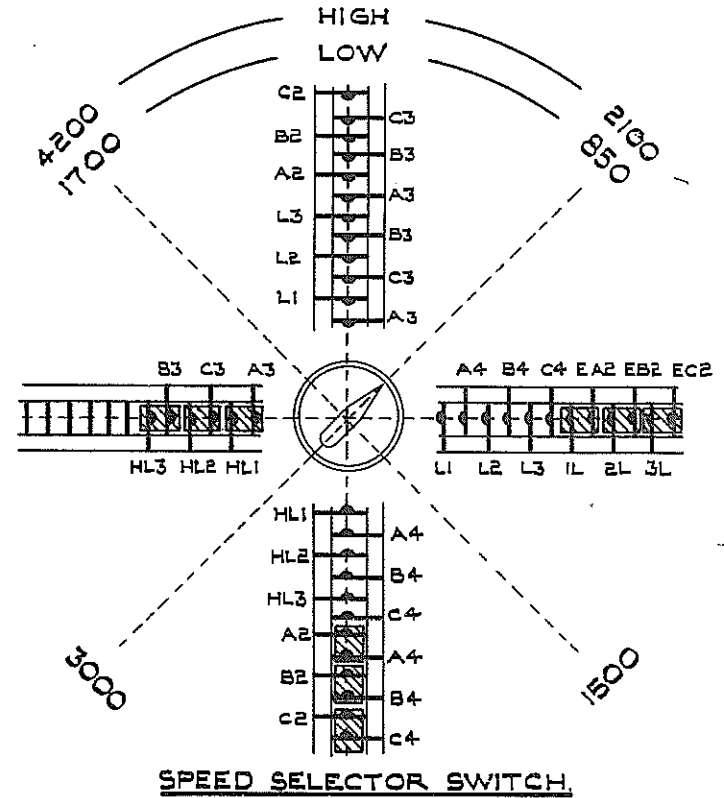

SPEED SELECTOR SWITCH.

▲ FIXED CONTACTS.
 ▨ MOVING CONTACTS.

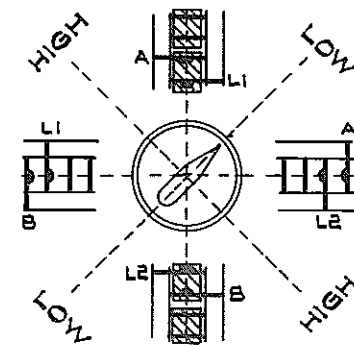

The following pages numbered 25 to 33 illustrate the application of the cutter equipment which is supplied with the machine and the variety of cuts that can be made using the movements available on the cutter spindle.

The following cutter information refers to woodcutting only. For information on cutters suitable for cutting brass and aluminium refer to Booklet No. 765.

APPLICATION OF CUTTER EQUIPMENT.

$\frac{1}{4}$ " - $10\frac{1}{2}$ " DIAMETER COREBOX CUTTERS.

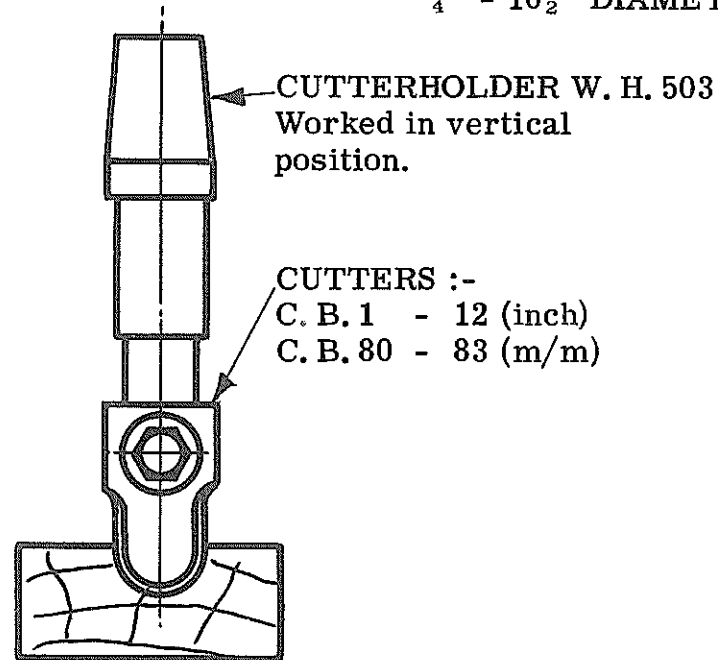

VERY SMALL COREBOX CUTTERS.

$\frac{1}{4}$ " - $1.1/16$ " dia. (10 - 25 m/m)

Main spindle speed 4200 r. p. m.

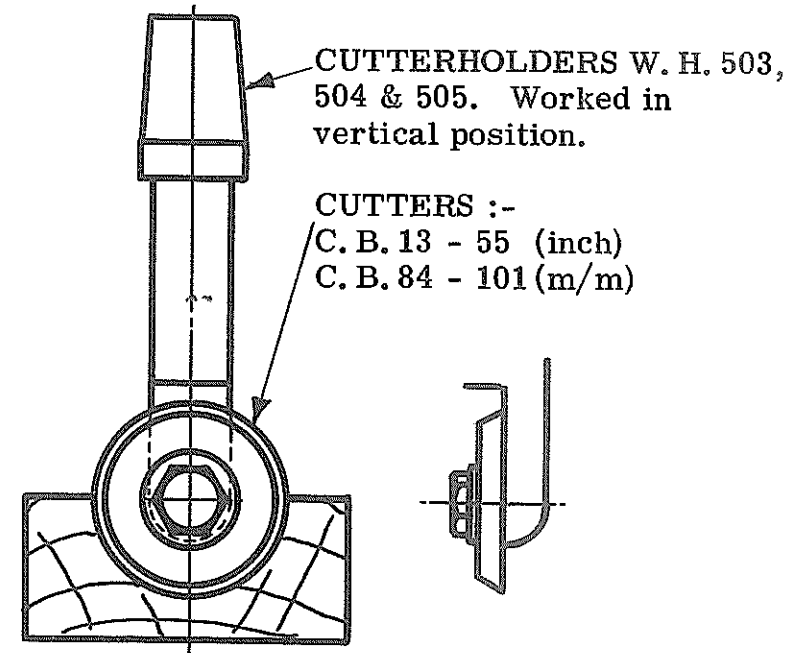

SMALL COREBOX CUTTERS.

$1.1/8$ " - $4\frac{1}{2}$ " dia. (30 - 115 m/m.)

Main spindle speed 4200 - 3000 r. p. m.

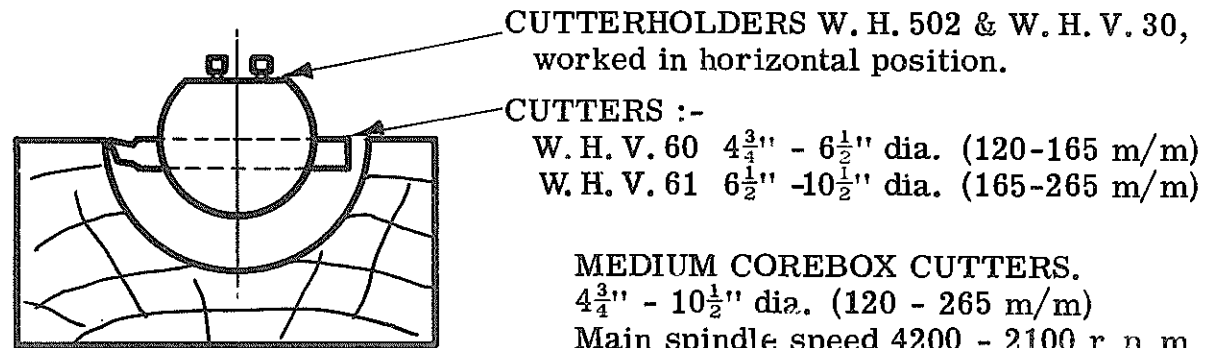

MEDIUM COREBOX CUTTERS.

$4\frac{3}{4}$ " - $10\frac{1}{2}$ " dia. (120 - 265 m/m)

Main spindle speed 4200 - 2100 r. p. m.

APPLICATION OF CUTTER EQUIPMENT.

7½" - 30" DIAMETER COREBOX CUTTERS.

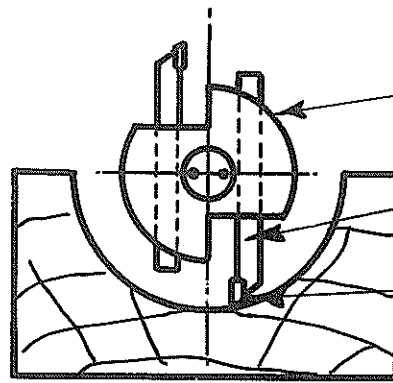

CUTTERHEAD W. H. C. 50, worked in horizontal position using securing pin.

CUTTER ARMS 7½" - 14½" dia. (190-370 m/m)

SET OF SHAPED CUTTERS W. H. C. 55 - 59.

Main spindle speed 3000 - 2100 r. p. m.

11" - 30" DIAMETER COREBOX CUTTERS (280-760 m/m)

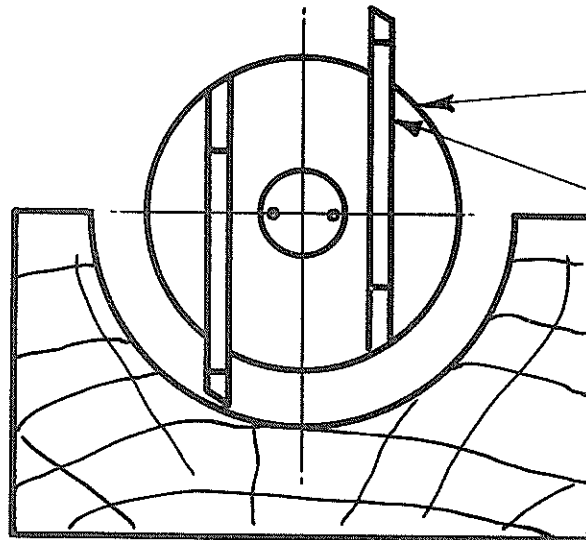

CUTTER DISCS W. H. V. 31, 32 & 33, worked in horizontal position.

CUTTERS W. H. V. 37.

Main spindle speed 2100 - 850 r. p. m.

ALTERNATIVE METHODS OF MOUNTING CUTTERHEAD W. H. C. 50.
 ON MAIN CUTTER SPINDLE. ON SPINDLE OF REVOLUBLE HEAD WXRI.

This method of mounting is used for the heavier classes of work, and enables the cutter bars to be fixed close to the bearings.

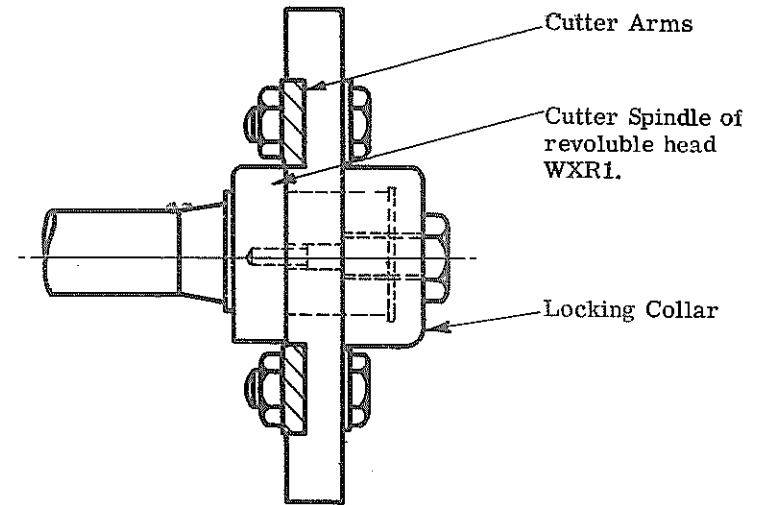
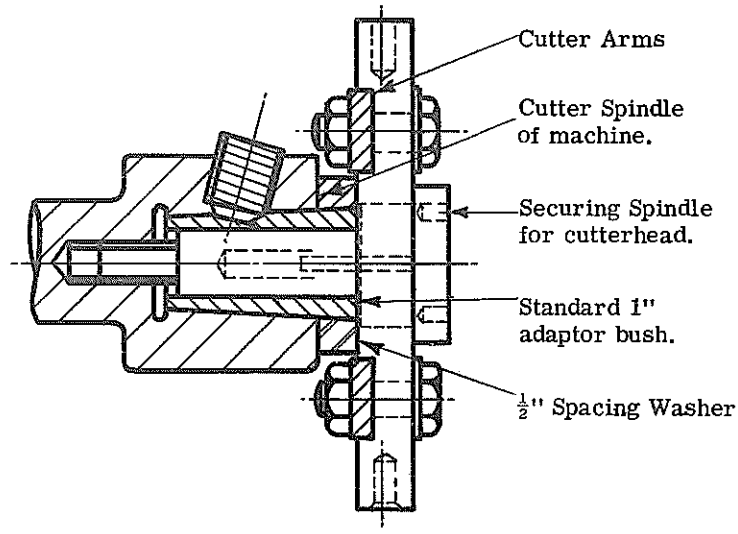

This method of mounting is used for machining coreboxes with dead ends.

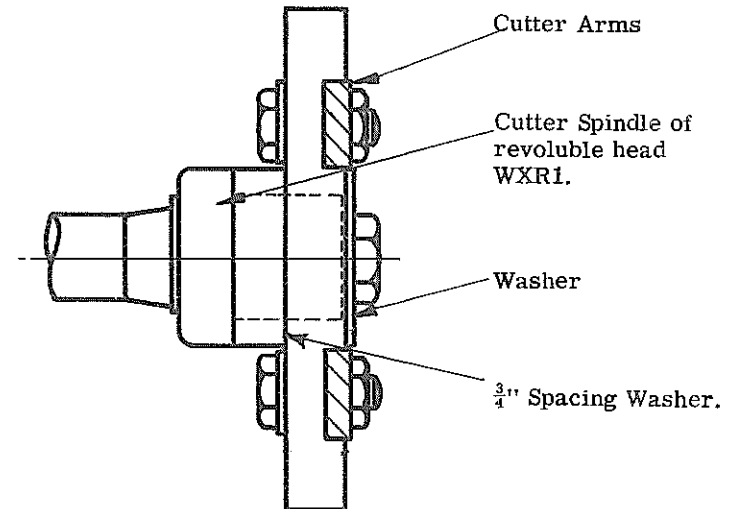
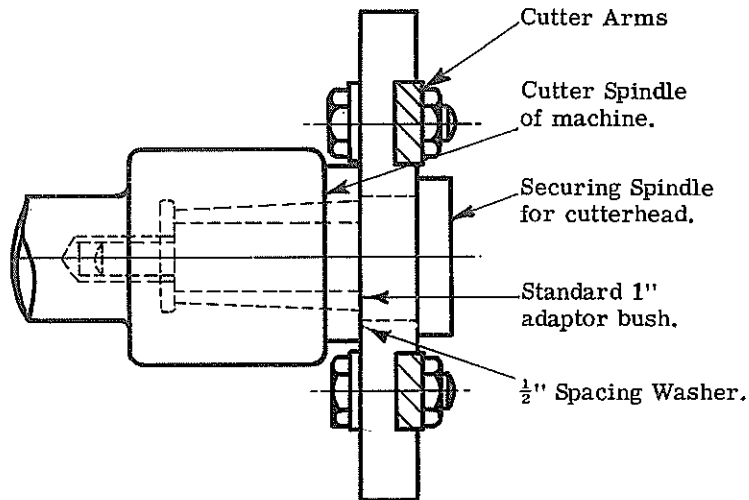

APPLICATION OF CUTTER EQUIPMENT (CONTD.)

$2\frac{1}{4}$ " - $14\frac{1}{2}$ " DIAMETER COREBOXES USING REVOLUBLE HEAD.

The revoluble cutterhead, page 19, is used for working coreboxes where main spindle cannot be admitted.

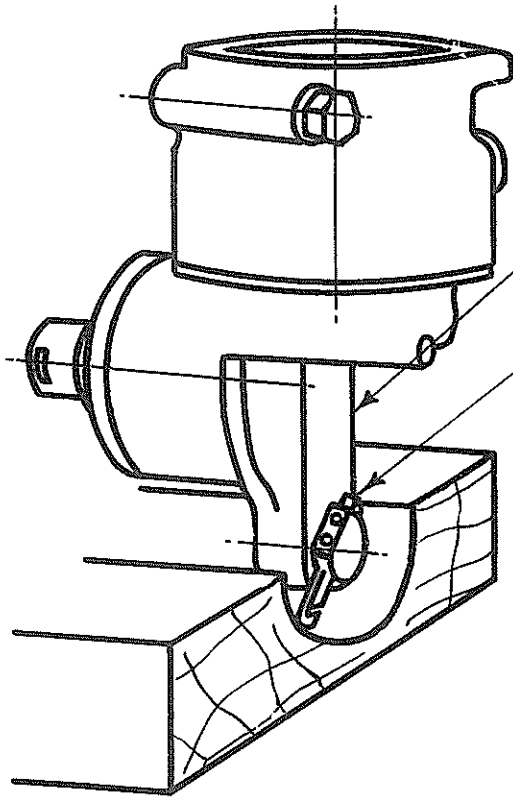

REVOLUBLE CUTTERHEAD W. X. R. 2.
worked in vertical position.

CUTTERS W. H. R. 50 & 51.
 $2\frac{1}{4}$ " to 7" dia. (55 - 175 m/m)
Run main spindle at 4200 - 3000 r. p. m.

CUTTERS FOR SPHERICAL WORK.

W. P. R. 110 & 111.
 $3\frac{1}{2}$ " to 7" dia. (89 - 175 m/m)
Run main spindle speed 4200 - 3000 r. p. m.

REVOLUBLE CUTTERHEAD W. X. R. 1.
worked in vertical position.

CUTTERS W. H. R. 50 & 51, also
Expanding Cutterhead W. H. C. 50.
 $4\frac{1}{2}$ " - $14\frac{1}{2}$ " dia. (115 - 370 m/m)

Run main spindle speed 4200 - 2100 r. p. m.

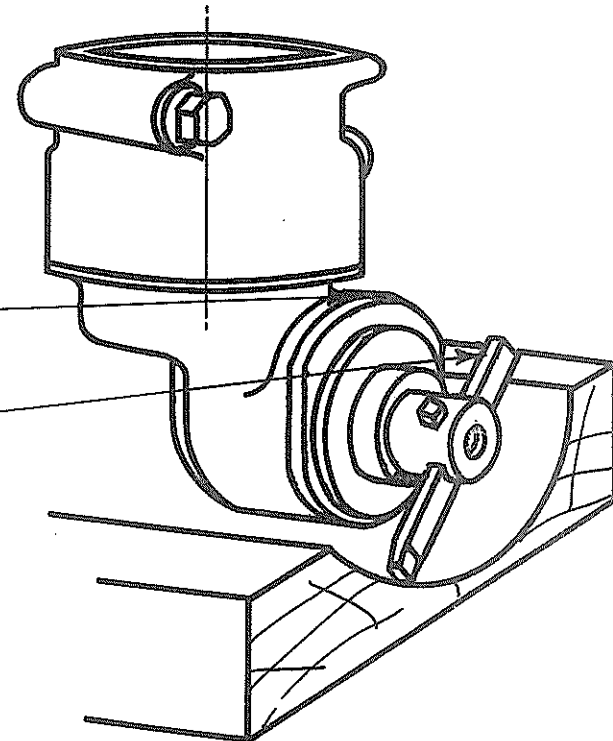

APPLICATION OF CUTTER EQUIPMENT

1 - 8 1/4" DIA. CHAMBERING CUTTERS.

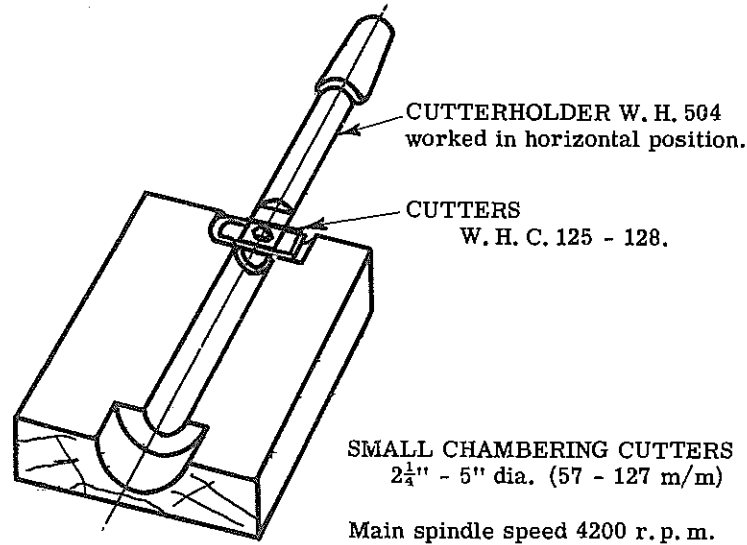

LARGE CHAMBERING AND
VALVE CORE CUTTERS.

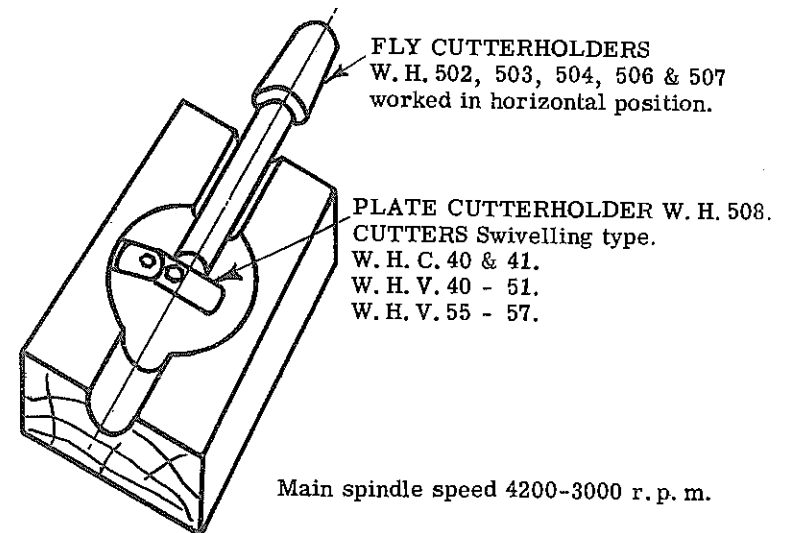
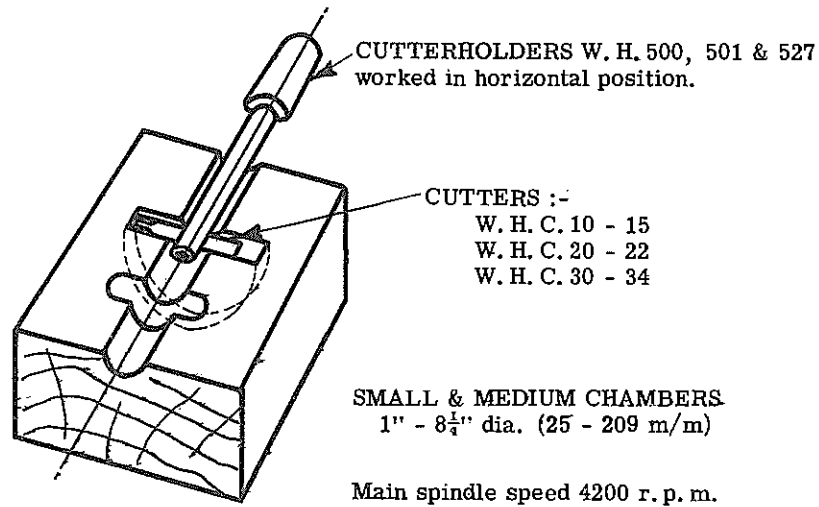
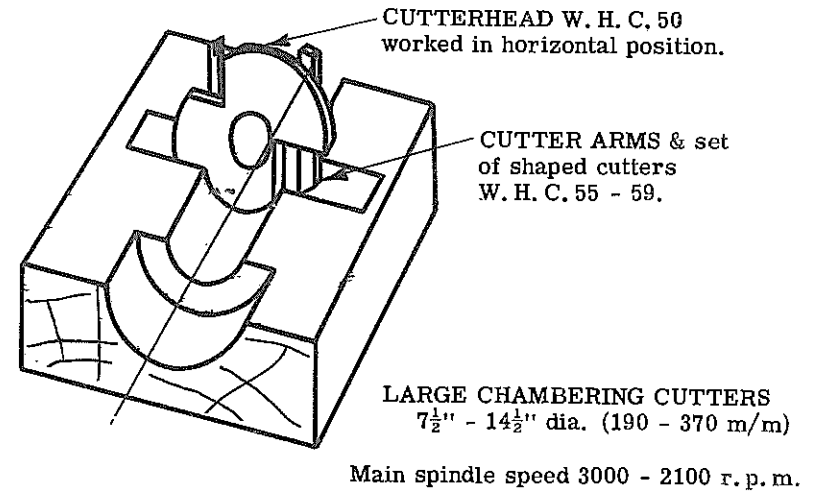

APPLICATION OF CUTTER EQUIPMENT

CORNER ROUNDING CUTTERS

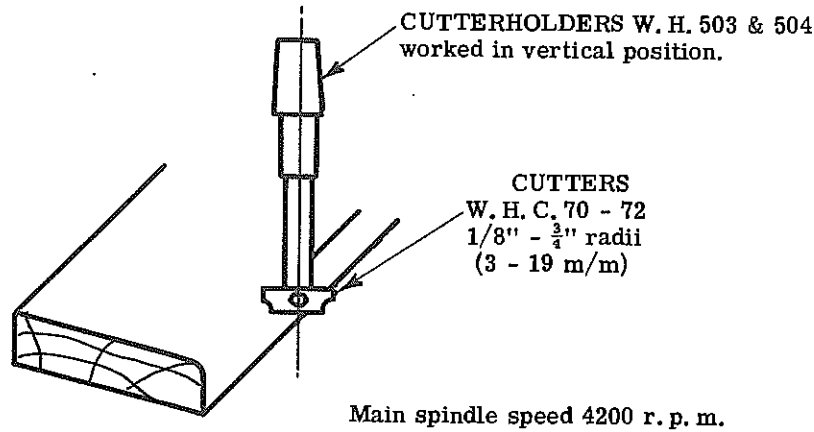

PATTERN OR RADIUS CUTTERS

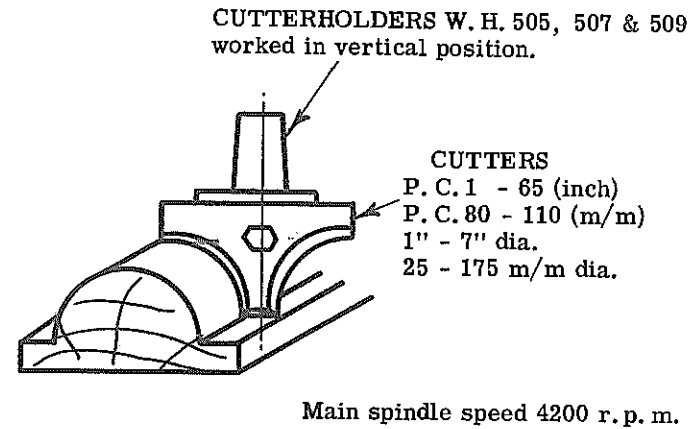

HALF-LAPPING AND TENONING

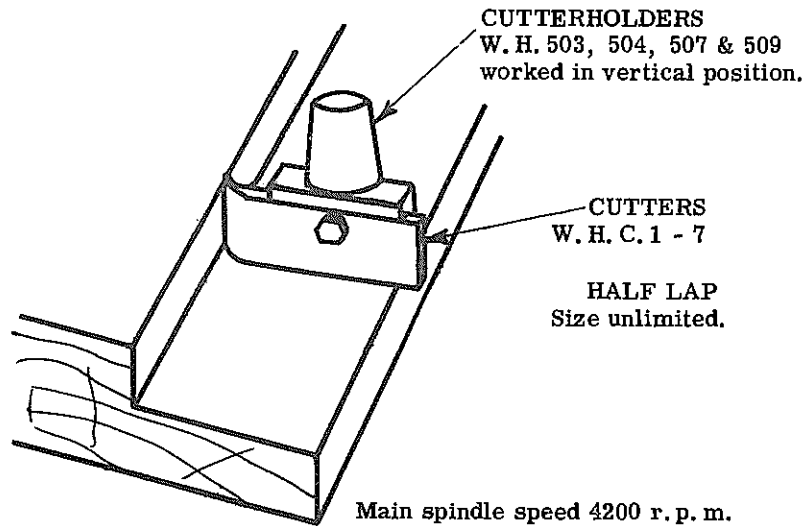

CUTTERHOLDER W. H. C. 140 worked in vertical position.

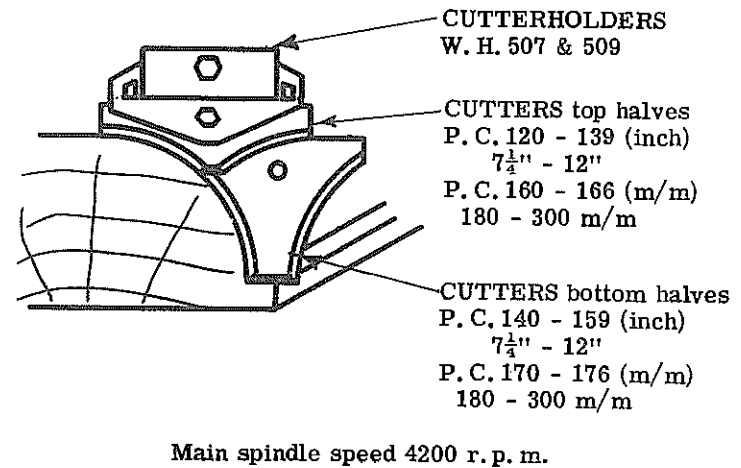

APPLICATION OF CUTTER EQUIPMENT

$\frac{1}{4}$ " - 6" DIA. BORING & SLOTTING CUTTERS.

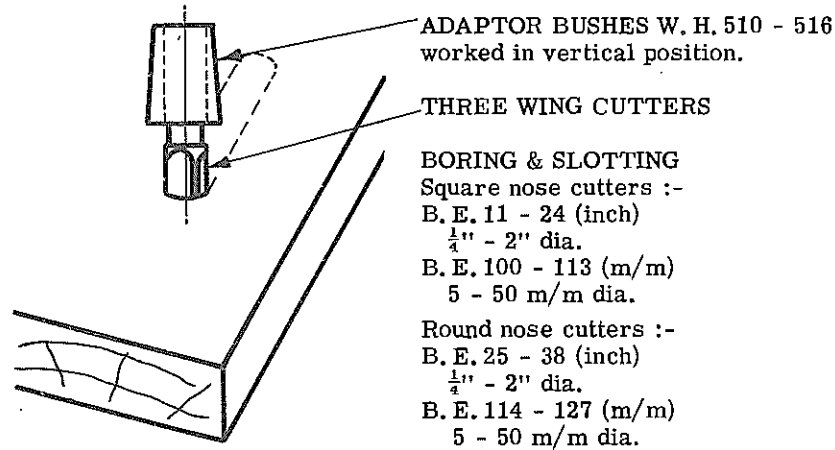

Main spindle speed 4200 r. p. m.

BORING, TAPER & PARALLEL PORTHOLE CUTTERS.

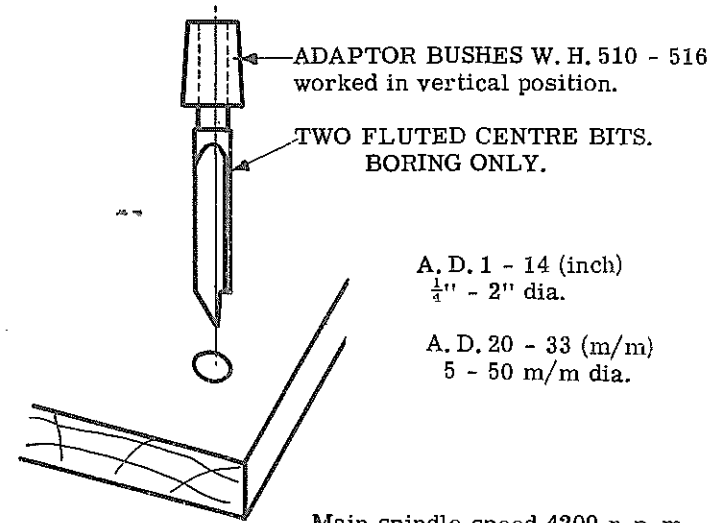

Main spindle speed 4200 r. p. m.

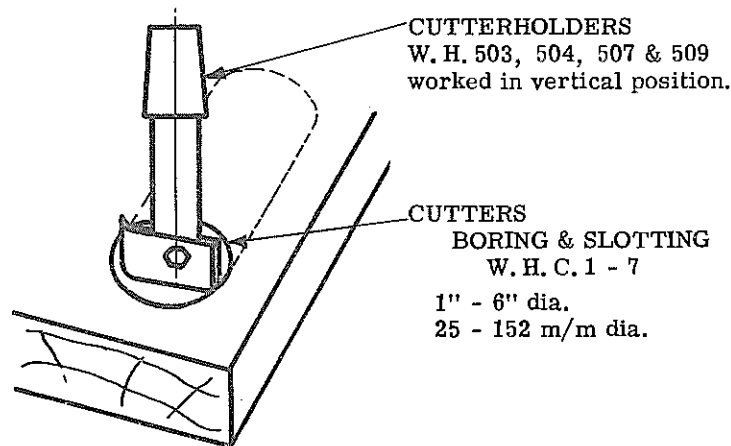

Main spindle speed 4200 r. p. m.

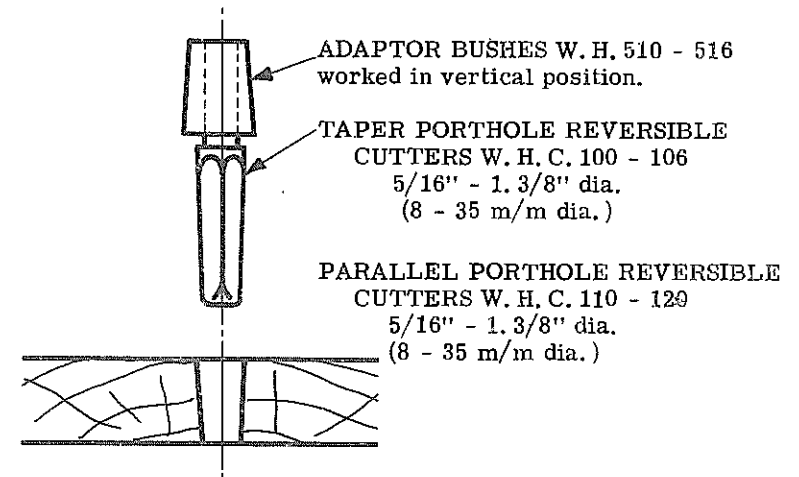

Main spindle speed 4200 r. p. m.

APPLICATION OF CUTTER EQUIPMENT

DOVETAIL CUTTERS AND SAFETY
CIRCULAR CUTTERBLOCK

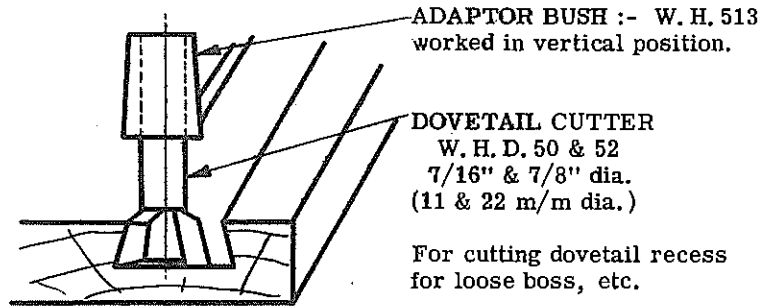

ADAPTOR BUSH :- W. H. 513
worked in vertical position.

DOVETAIL CUTTER
W. H. D. 50 & 52
7/16" & 7/8" dia.
(11 & 22 m/m dia.)

For cutting dovetail recess
for loose boss, etc.

Main spindle speed 4200 r. p. m.

ROUTING AND RECESSING CUTTERS

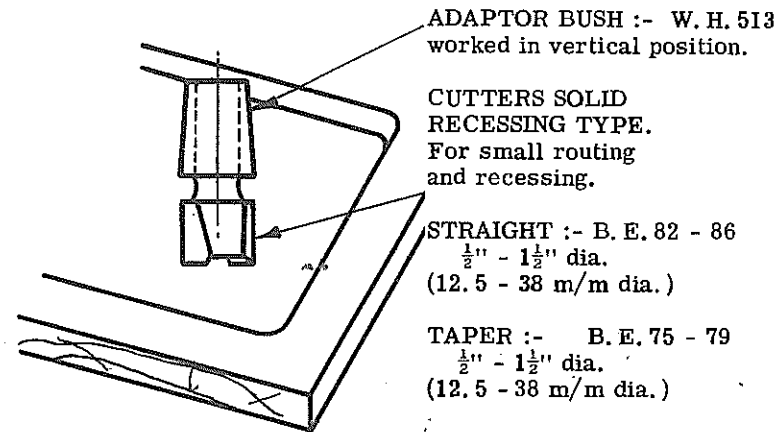

ADAPTOR BUSH :- W. H. 513
worked in vertical position.

CUTTERS SOLID
RECESSING TYPE.
For small routing
and recessing.

STRAIGHT :- B. E. 82 - 86
1/2" - 1 1/2" dia.
(12.5 - 38 m/m dia.)

TAPER :- B. E. 75 - 79
1/2" - 1 1/2" dia.
(12.5 - 38 m/m dia.)

Main spindle speed 4200 r. p. m.

Opposite hand cutters can be supplied if required.

SAFETY CIRCULAR
CUTTERBLOCK

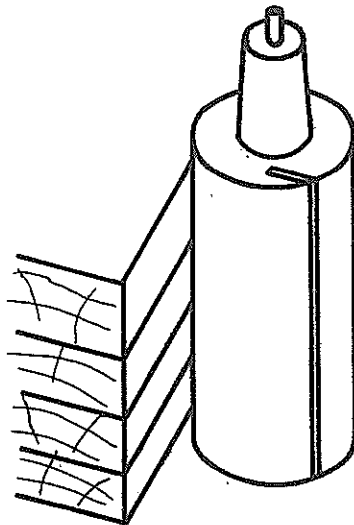

6" long 3 1/2" dia. W. H. C. 90.
Spindle position to suit work.
For planing built up timber
up to 6" deep.

CUTTERS V. P. 1 (1-pair)
Main spindle speed 4200 r. p. m.

CUTTERHEADS
W. H. C. 96, 97 & 98.
Worked in vertical position.

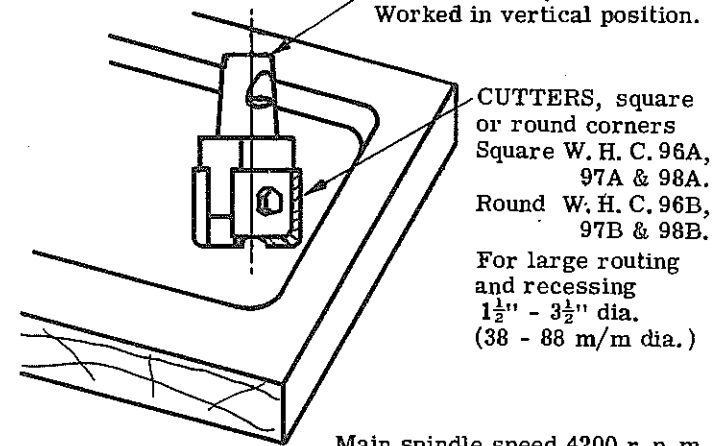

CUTTERS, square
or round corners
Square W. H. C. 96A,
97A & 98A.
Round W. H. C. 96B,
97B & 98B.

For large routing
and recessing
1 1/2" - 3 1/2" dia.
(38 - 88 m/m dia.)

Main spindle speed 4200 r. p. m.

APPLICATION OF CUTTER EQUIPMENT
SLOTTED COLLARS, CUTTERS AND SCREWED SPINDLE.

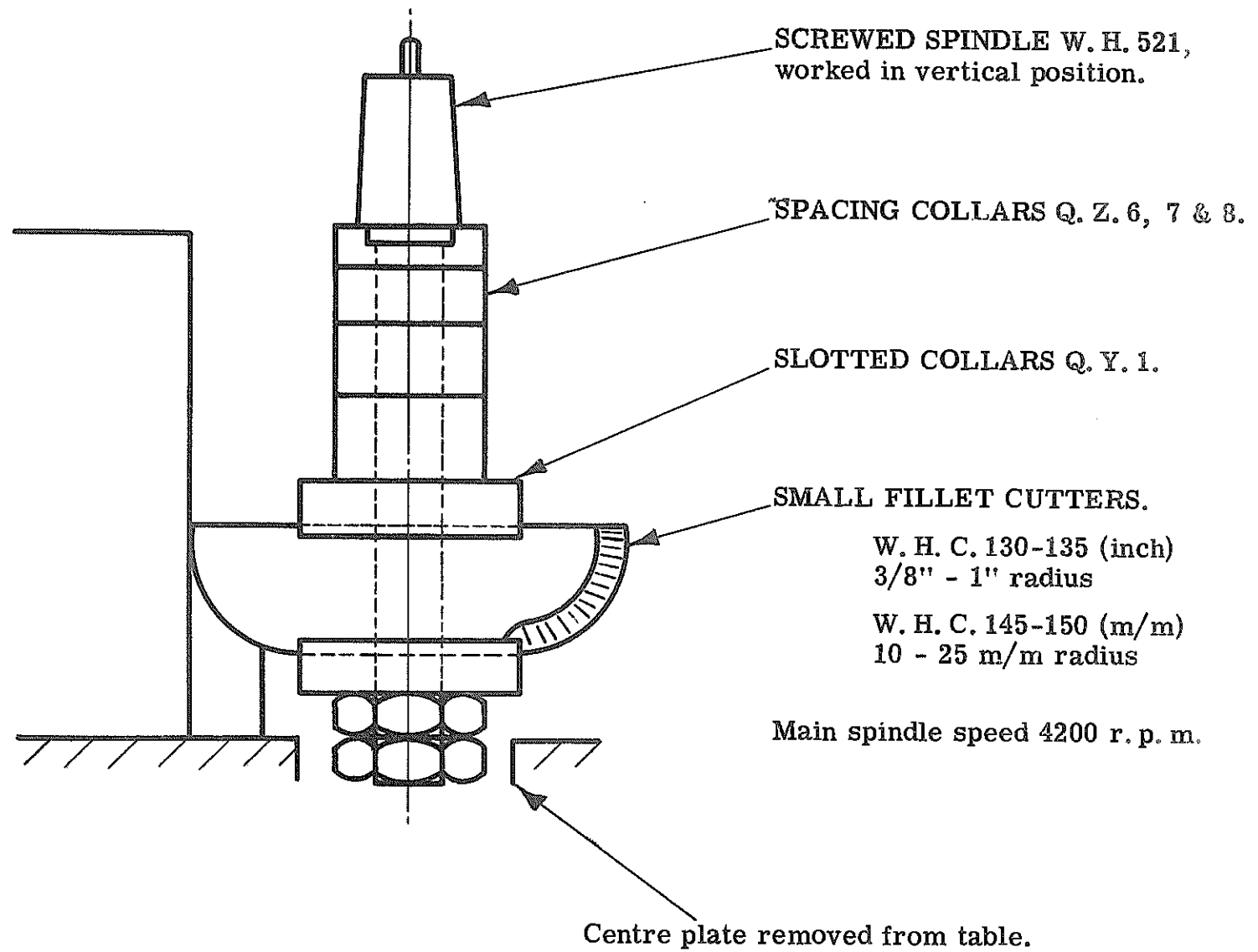

The following pages show the various shapes that can be generated using the compound movements of the table.

It should be noted that once the work is fixed on the table and the cutter accurately positioned with respect to the work, the various movements - straight line, angular, circular, etc. are precision functions of the machine. The operator controls the length of travel only of the work past the cutter, otherwise the various shapes are not in any way worked freehand.

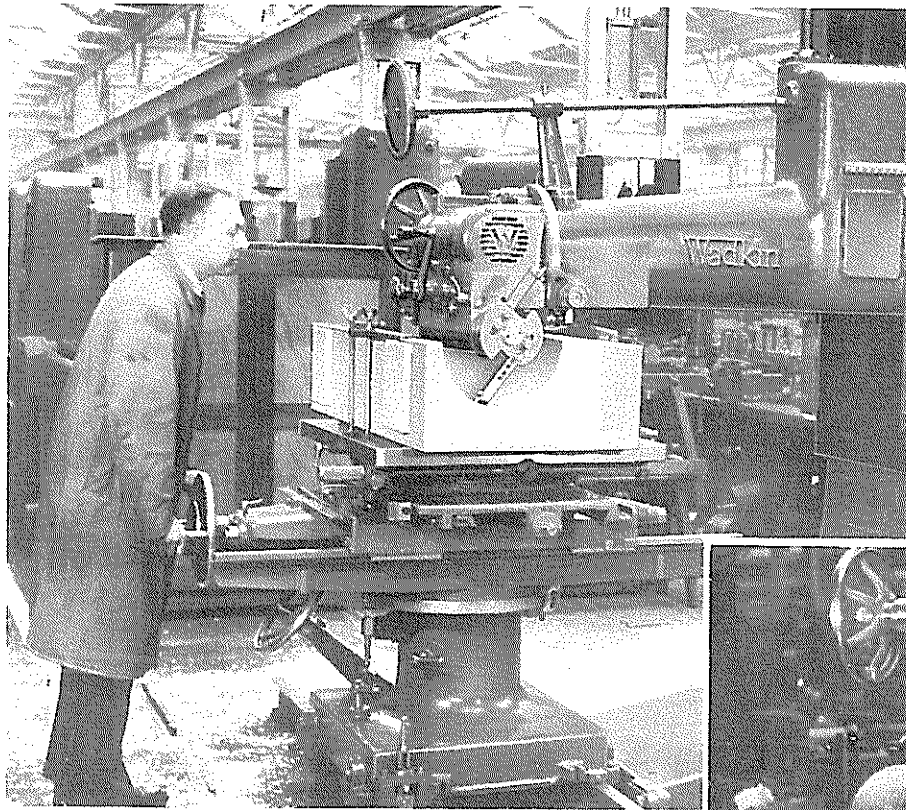

Gear cutting, this gives an example of cross traverse table movement.

Cutting corebox as above gives example of longitudinal movement of top table only.

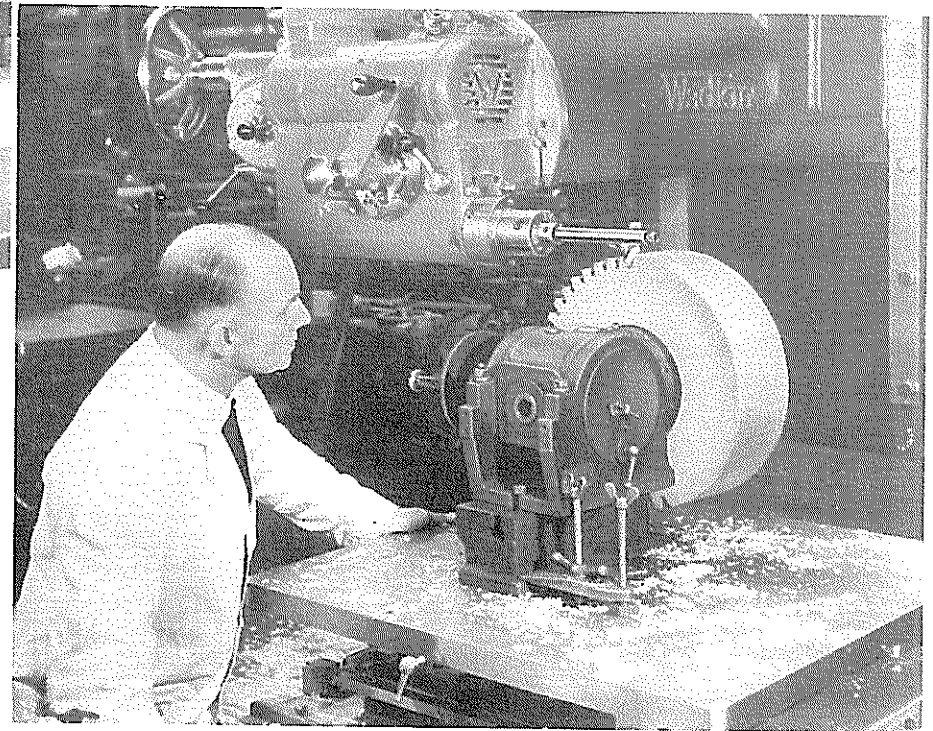

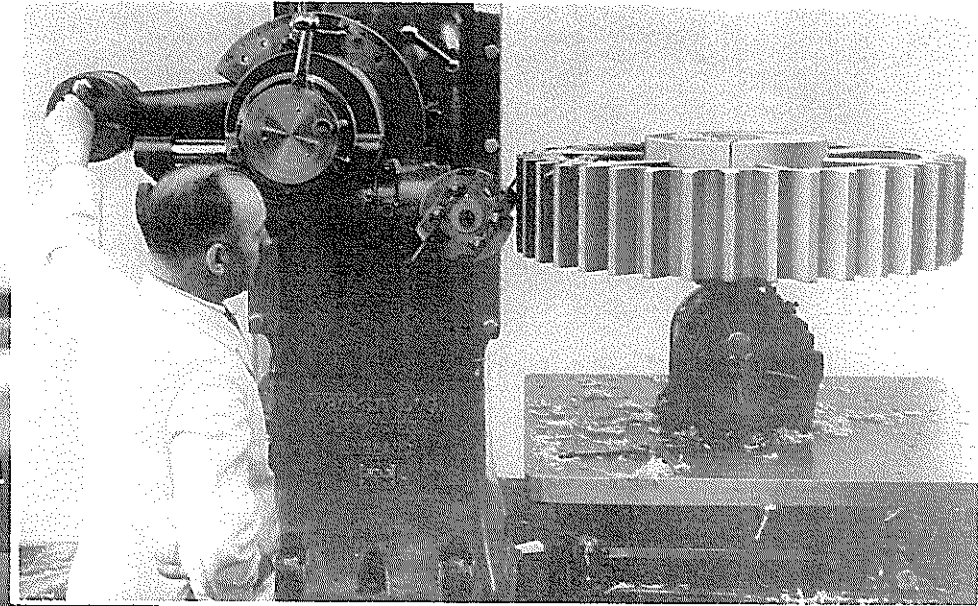
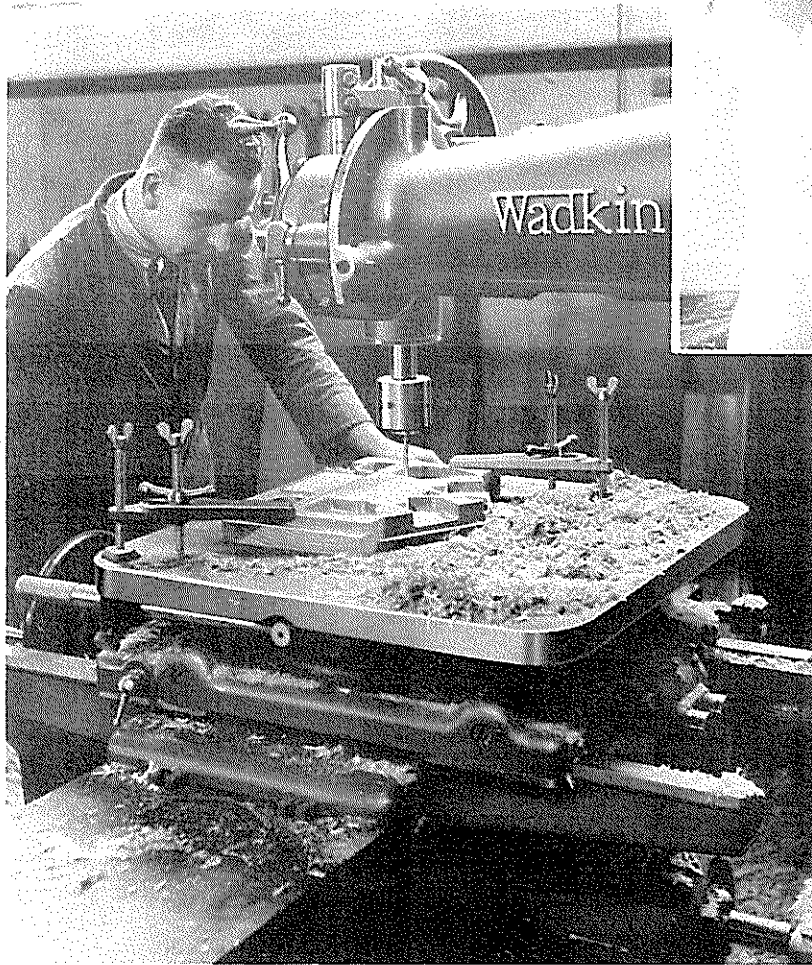

Large diameter gear cutting gives example of vertical feed motion of cutter head with whole table offset on rails.

Routing pockets gives an example of combined cross and longitudinal table movement.

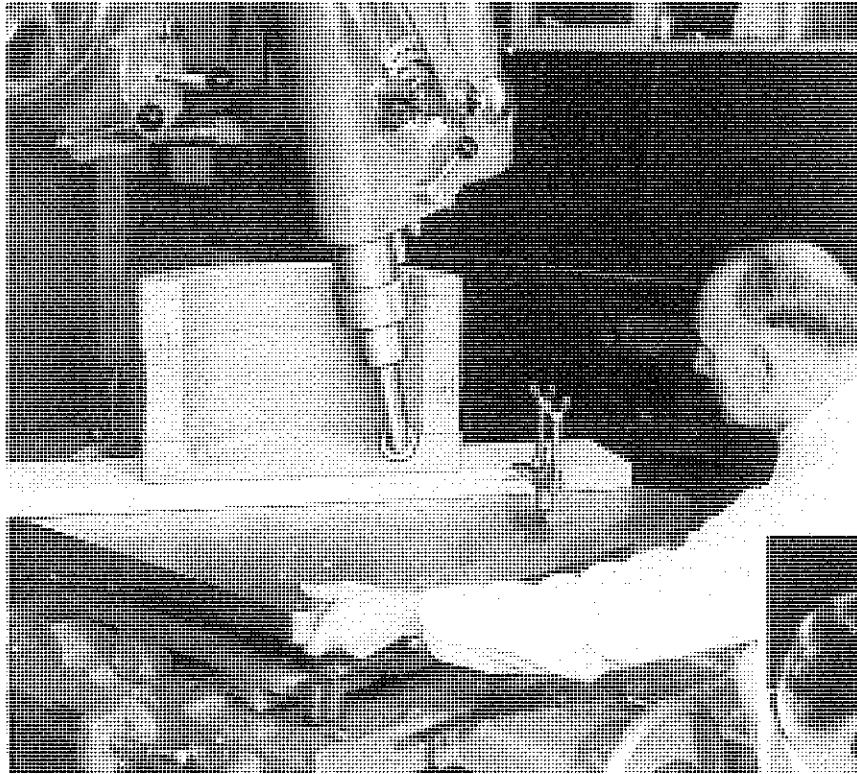

Radial cut in bottom of corebox being worked by use of circular feed motion of top rotating table movement. Cutterhead canted to clear work.

Working bend in cylinder corebox using combined longitudinal and top radial feed movements. This operation necessitates the use of the revoluble head WXR1.

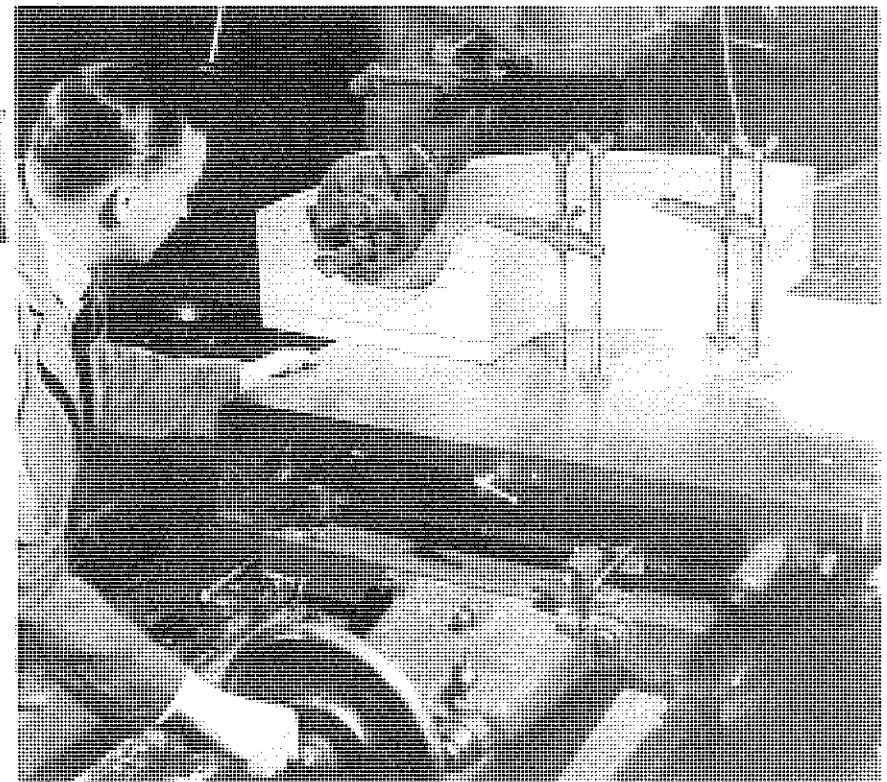

Example of angular work, angle obtained by setting rotating top table and feed from cross traverse.

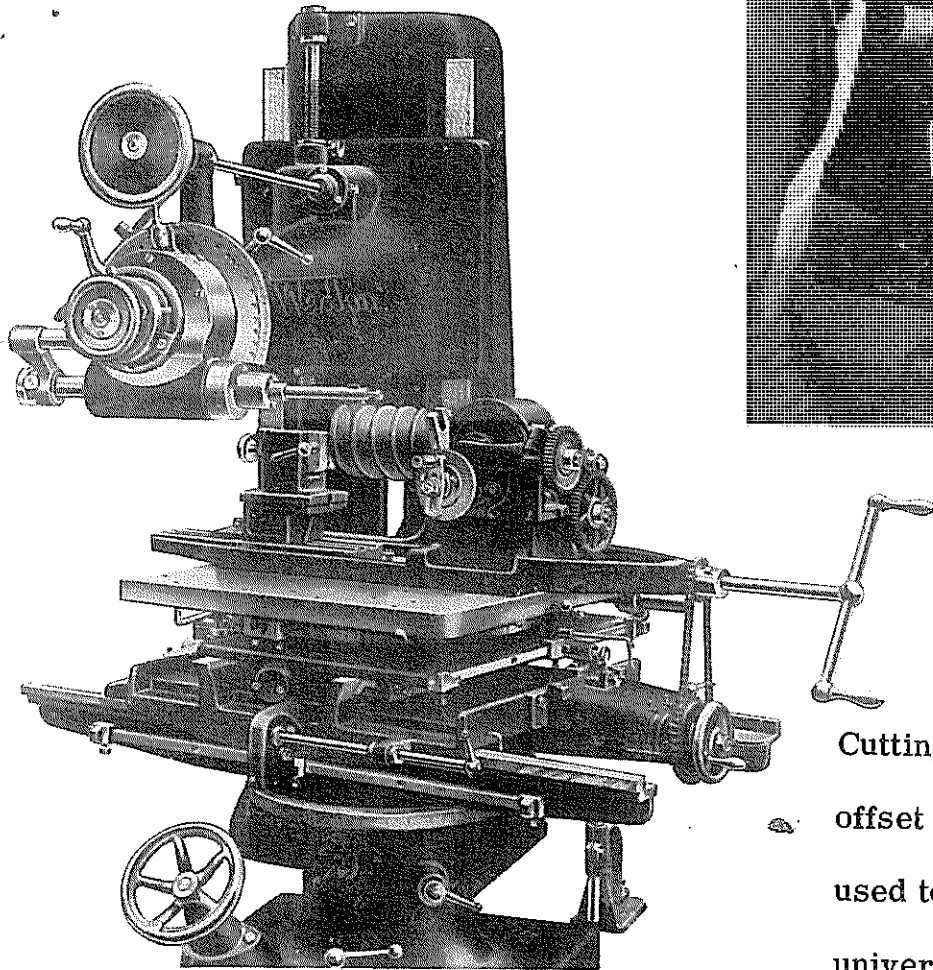
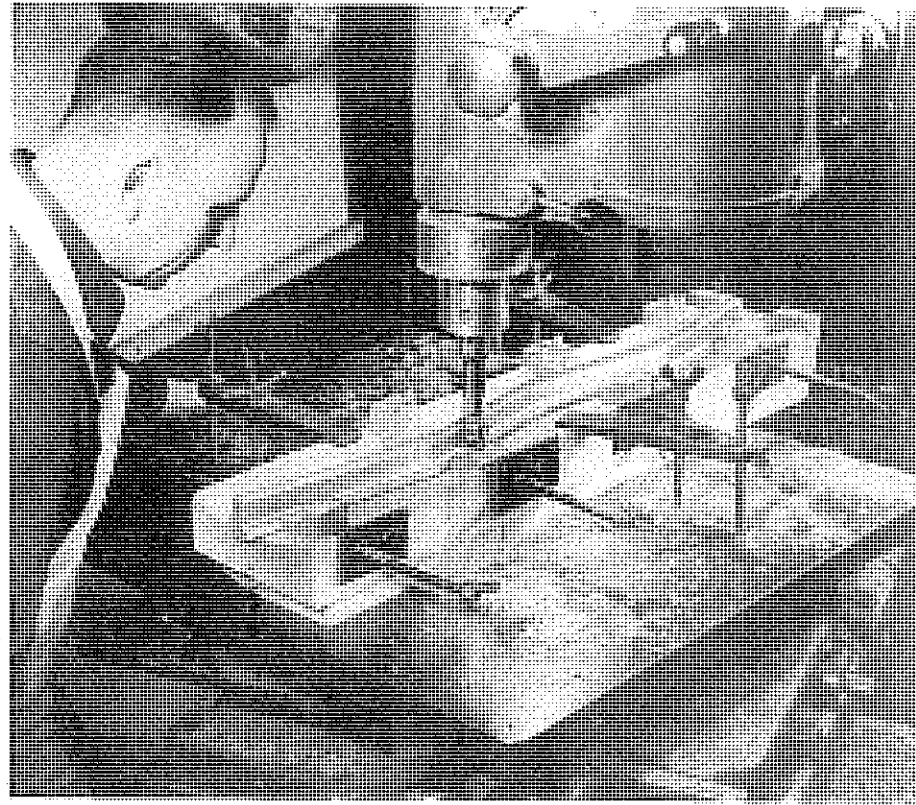

Cutting worm, example of whole table unit offset on rails, bottom rotary movement used to obtain lead and the coupling of universal dividing head to feed screw.

Example of combined cross, longitudinal, top and bottom radial movements. Use of the top rotating movement for one radius and the bottom for the other, enables more than one radius from different centres to be worked without disturbing the work.

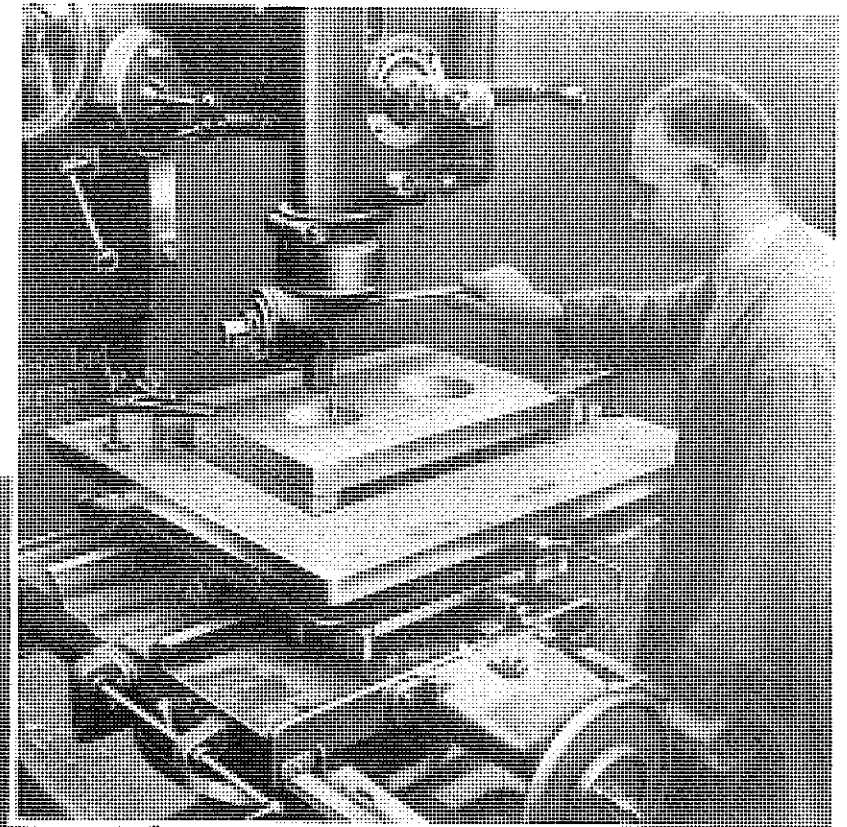
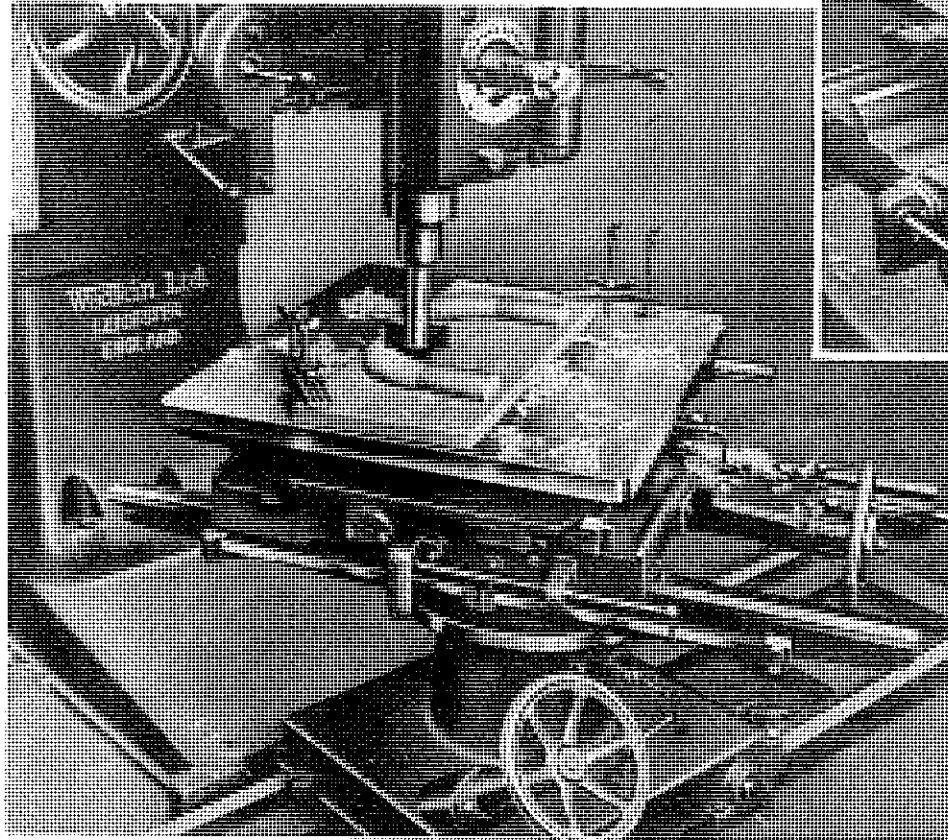

Revoluble cutterhead being revolved in a plane at right angles to the plane of rotation of the cutter while the latter is in motion, so that the cutter rotates in a spherical path.

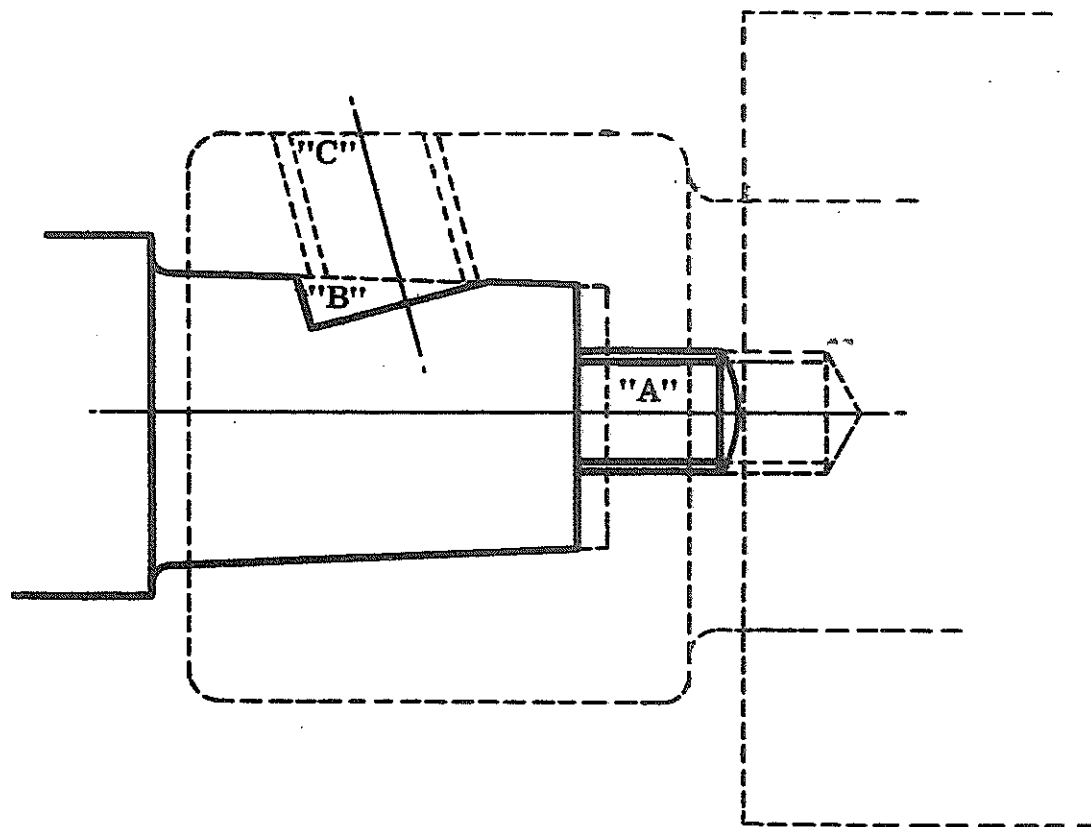

When supplying cutter-holders, cutter-blocks, etc. with the 5/8" screwed end "A", after the machine has left our Works, it is impossible for us to mill the flat "B" as the radial position can only be found, and is only correct, on the particular machine for which the tools are required. It is necessary, therefore, for our customer on receipt of such equipment to remove the locking screw from spindle chuck, see that the taper bore is clean and free from burrs, and then screw each holder tightly home and mark the position through the locking screw hole "C". The flat can then be milled or carefully filed, using one of the holders supplied with the machine as a pattern for the lateral position and angles. When carrying out this work it is advisable to allow a very small amount radially for the tools pulling round a little farther with continual use.

CUTTER GRINDING

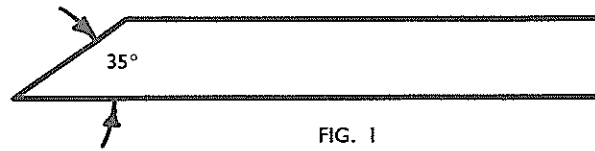

FIG. 1



FIG. 2

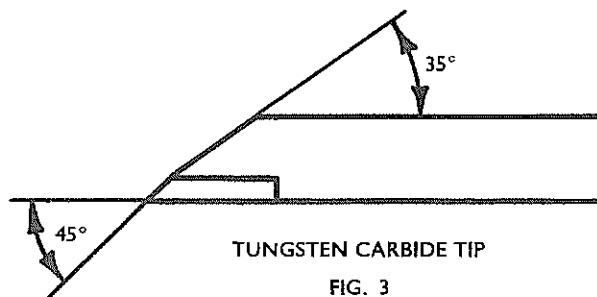

FIG. 3

Cutters should be ground carefully avoiding any overheating as this will crack or soften cutters so that they will not stand up to the work. A solution of soluble oil and water should be handy and the cutters should be held in this occasionally to cool them. This solution will also prevent rusting. Cutters should never be allowed to become discoloured during grinding, as this indicates overheating.

The correct cutter angle of 35° for most cutters should be maintained, this is to give the correct strength to the cutting edge. When hollow grinding is carried out, the angle of the cutting edge should be kept as near 35° as possible, see Figs. 1 and 2.

Hollow grinding is recommended wherever possible, as a perfect cutting edge is more easily obtained by stoning. When stoning a flat ground cutter a good edge is more difficult to obtain due to the tendency to rock the stone and leave a convex face.

Good open grain wheels should be used and not allowed to become glazed, as this will cause excessive heat.

About 12" diameter for new wheels gives the best radius for the hollow grind and the economic life. 8" wheels used down to 6" leave the grind too hollow.

Tungsten carbide tipped cutters should be purchased to the shape required and only need re-grinding. In this case cutters should be relieved at 35° on steel and the tips finished with a diamond impregnated wheel at 45° as shown, using only very light cuts to prevent cracking. The diamond wheel should not be allowed to touch the steel backing as this clogs the wheel and causes excessive heat. Where available a copious flow of coolant should be used. They may be honed with a diamond hand lap, as the cutter becomes dull, until a re-grind is necessary. A thin oil lubricant should be used on the hand lap.

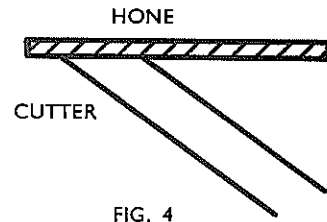

FIG. 4

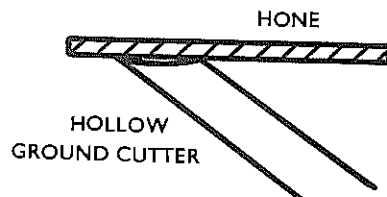

FIG. 5

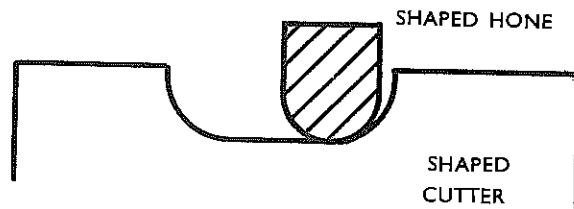

FIG. 6

HONING.

Cutters must have a razor sharp cutting edge before commencing to cut. To obtain this edge it is necessary to hone the cutters using a 142 carborundum slip stone. This will ensure a good finish on the wood and an easy feed. Dull cutters give a poor, rough and plucked out finish and make it difficult to feed the job past the cutters. Honing should be done by a reciprocating or rotary motion on the cutter, using a little paraffin to give "bite" to the stone. The honing stone is a much finer grit than the grindwheel and leaves a sharp keen edge. A number of honing stones of different shapes, e. g. round or square sticks will be found helpful in honing shaped cutters.

GRINDING INSTRUCTIONS FOR VARIOUS TYPES OF CUTTERS.

"G" DENOTES FACE TO BE GROUND OR STONED.

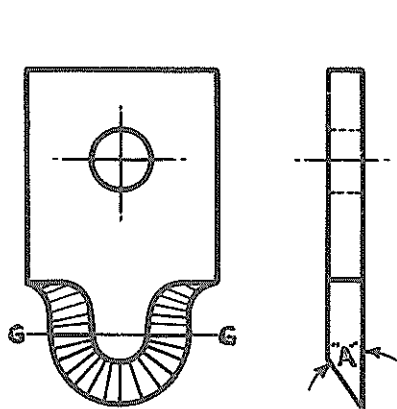

ITEM 1.

Corebox Cutters.

C. B. 1 - 7 & 80-81. "A" = 45°
C. B. 8 - 12 & 82-83. "A" = 30°

Make template to shape,
grind cutters free hand.

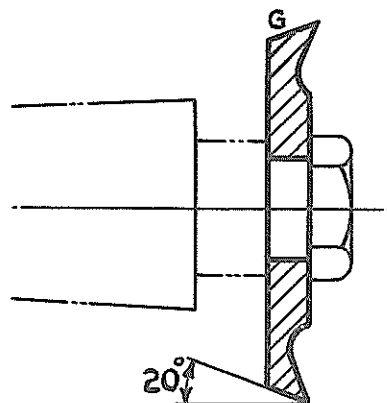

ITEM 2.

Corebox Cutters.

C. B. 13-55 & 84 - 101.

Make arbor to fit machine spindle
and top up cutter with oil stone.
Alternatively grind on Universal
Cylindrical Grinder.

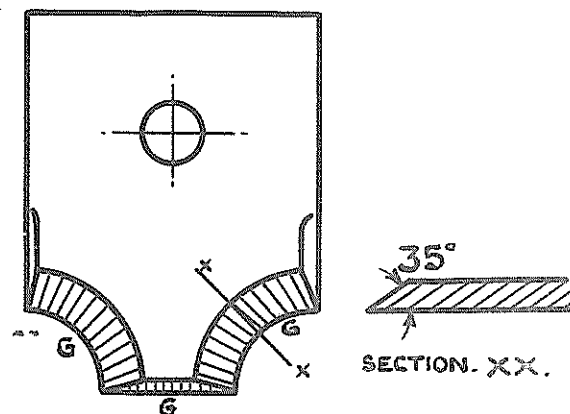

ITEM 2 & 2A.

Pattern Cutters.

P. C. 1 - 176.

Make template to shape,
grind cutters free hand.

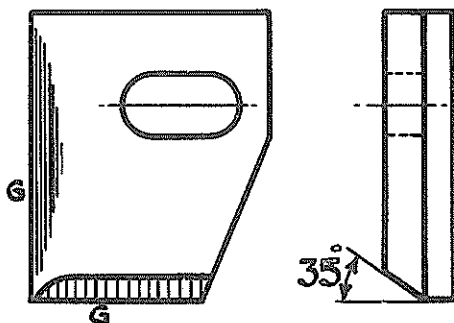

ITEM 3.

Hole and Slot Boring Cutters.

W. H. C. 1 - 7.

Grind free hand.

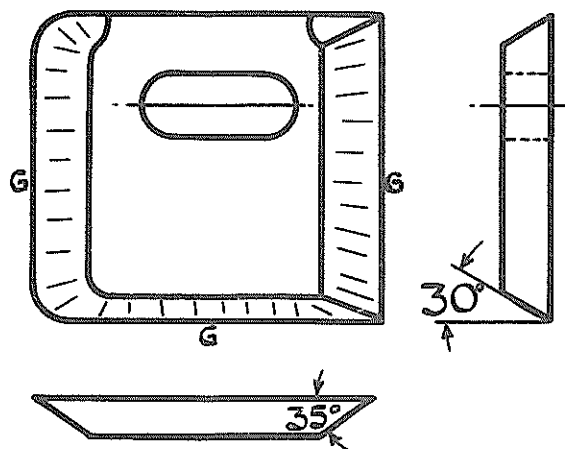

ITEM 4.

Chambering Cutter

W. H. C. 125 - 128.

Grind free hand.

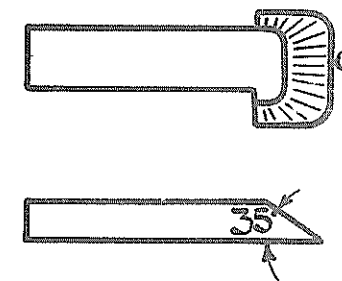

ITEM 5.

Set Over Dead End Cutter

W. H. C. 10 - 11.

Grind free hand

GRINDING INSTRUCTIONS (CONTD.) "G" DENOTES FACE TO BE GROUND OR STONED.

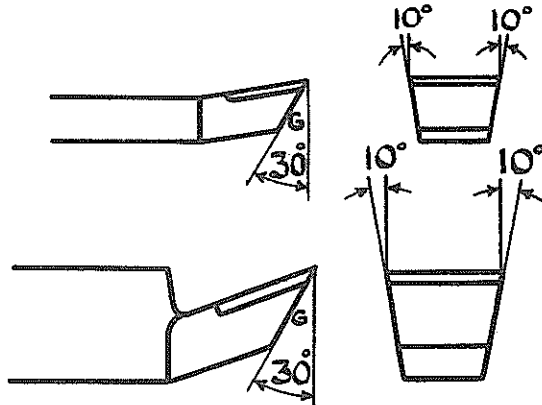

ITEM 6.
Set Over Dead End Cutters.
W. H. C. 12 - 15.
Grind free hand.

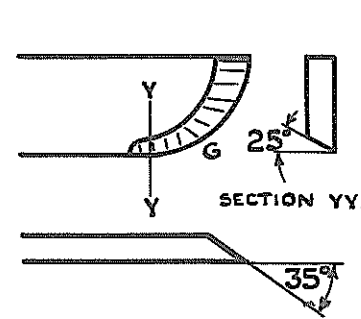

ITEM 7.
Small Fillet Cutters
W. H. C. 130-150
Make template to shape.
Grind free hand.
Balance in pairs.

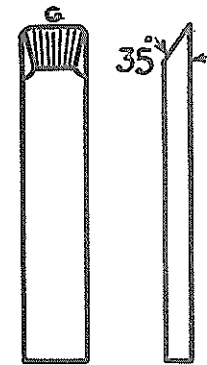

ITEM 8 & 8A.
Chambering Corebox
Fly Cutters.
W. H. C. 20 - 34.
Grind free hand.

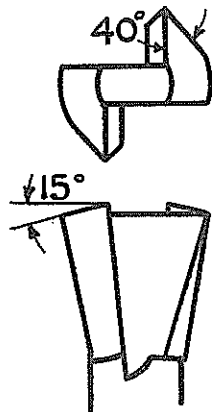

ITEM 9.
Dovetail Cutters
W. H. D. 50 - 53
Grind in flutes only, on
Tool and Cutter Grinder
such as Wadkin N. H.

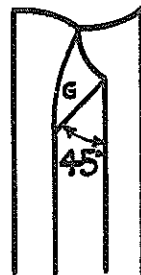

ITEMS 10, 11 & 12.
Boring Bits.
B. E. 11-38 & 100-127.
A. D. 1-14 & 20- 33.
Grind free hand.

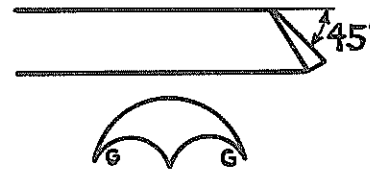

ITEMS 13 & 14
Reversible Porthole Cutters.
W. H. C. 100-106
W. H. C. 110-120
Stone or grind inside of flutes.

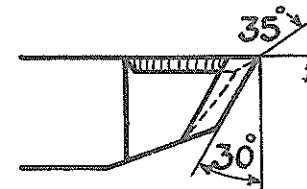

ITEM 17 & 19A
Gouge Cutter
W. H. V. 37 & 60 - 61.
Stone 35° angle on inside
of cutter.

CUTTER GRINDING (CONTD.) "G" DENOTES FACE TO BE GROUND OR STONED.

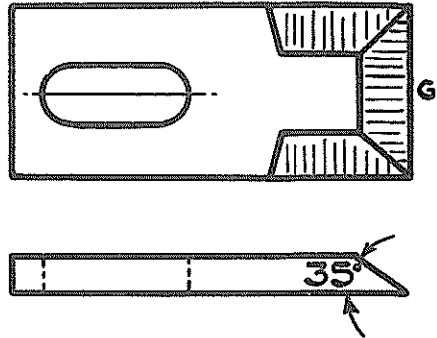

ITEM 18.
Swivelling Slotted Cutters.
W. H. V. 40 - 51
Grind free hand

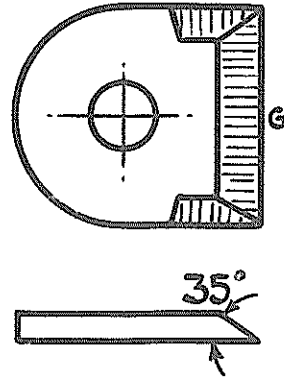

ITEMS 19 & 20.
Swivelling Cutters
W. H. V. 55 - 57
W. H. C. 40 - 41
Grind free hand

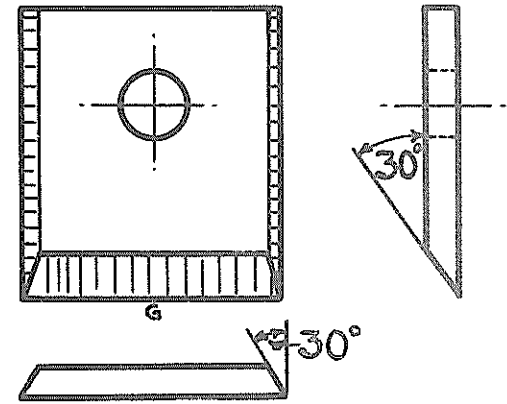

ITEM 22.
Chambering Cutters
W. H. C. 55 - 59
Grind free hand
Balance in pairs

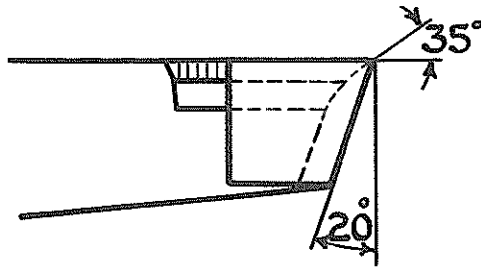

ITEM 23.
Hooked Gouge Cutter
W. P. R. 113.
Stone 35° angle on inside
of the cutter.

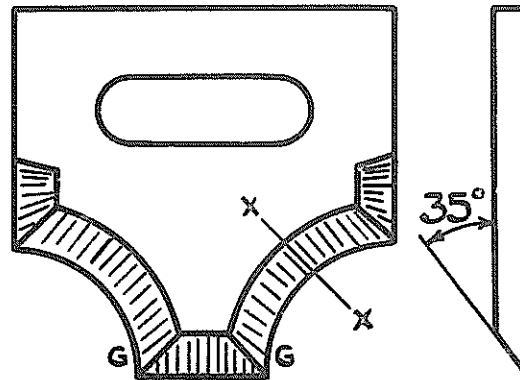

ITEM 24.
Corner Rounding Cutters
W. H. C. 70-72 & 75-77.
Make template to shape.
Grind cutter free hand.

SECTION XX.

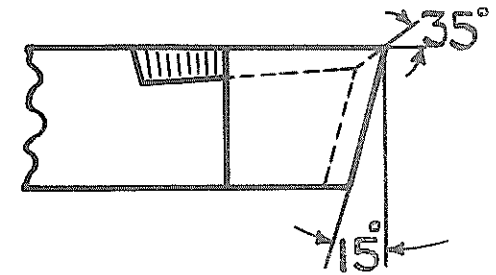

ITEM 25.
Hooked Gouge Cutter
W. H. R. 50 - 51
Stone 35° angle on the inside
of the cutter.

GRINDING INSTRUCTIONS (CONTD.)

"G" DENOTES FACE TO BE GROUND OR STONED.

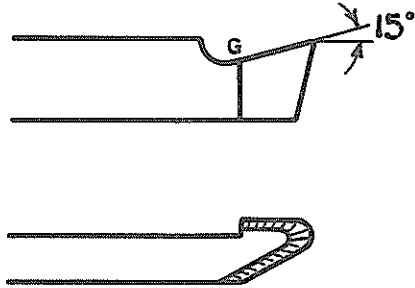

ITEM 25.
Spherical Cutters
W. P. R. 110-112
Grind 15° angle free hand,
stone sides if necessary.

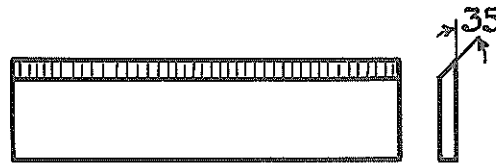

ITEM 28.
Knives for Circular Cutterblock
V. P. 1.
Grind on Universal or Straight Knife
Grinder. Balance in pairs.

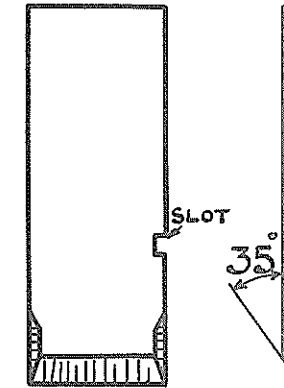

ITEM 30.
Adze Cutter for Trenching Head
K. T. 1 - 9
Grind free hand or on either Universal
or Straight Knife Grinder. Balance in
pairs. When necessary grind the back
of the slot to maintain cutting diameter.

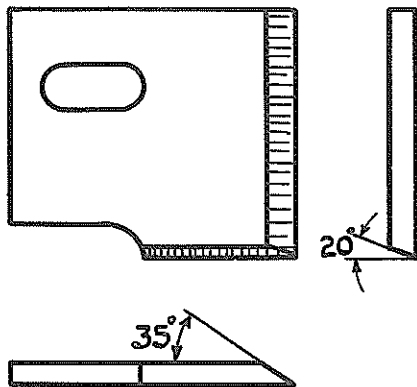

ITEM 32, 32A & 33
Routing Cutter.
W. H. C. 96, 97 & 98.
Grind free hand.
Balance in pairs.

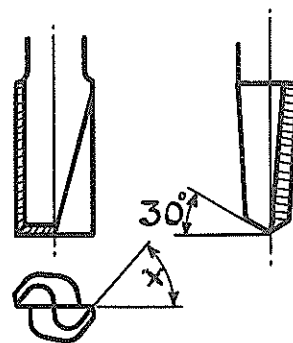

ITEM 34 & 35.
Solid Recessing Cutters.
B. E. 70, 75, 82 & 90 Angle "X" = 50°
B. E. 71-74, 76-79, 83-86 and 91-94
Angle "X" = 45°
Grind on the bottom and in the flutes,
on Wadkin Tool & Cutter Grinder N. H.
or similar machine.

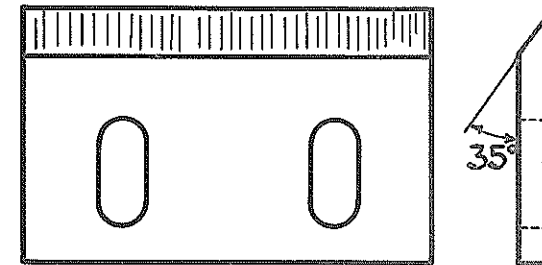

ITEM 36.
Tenon Head Cutters
W. H. T. 2
Make template to shape.
Grind cutter free hand.
Balance in pairs.

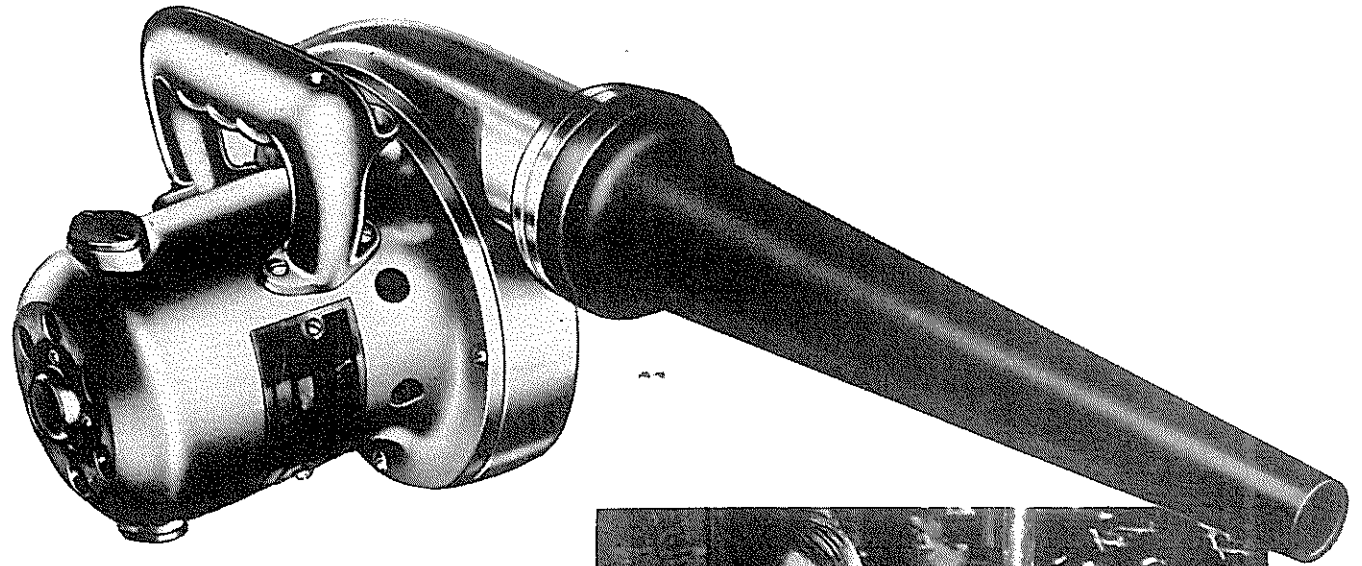

... blow away harmful dust, chips and dirt with a Wadkin Electric Blower

No motor can run at its maximum efficiency with its ventilating duct or control gear covered with dust and dirt. Sooner or later the resultant overheating will cause serious trouble.

Similarly, accumulations of chips and dust, in the mechanical parts of the machine can interfere with its efficiency. A few minutes a week for blowing down all Woodworking Machinery will be amply repaid in better and easier running, in increased life, and freedom from breakdown.

Blowers can be supplied for single phase A.C. or Direct Current for any voltage up to 250.

Please state voltage when ordering.



SAMPLE TYPE ORDER

MACHINE: WX

MACHINE NO: 1407

TEST NO: 68975

PARTS REQUIRED

1 - WX654/WP543 HEADSTOCK
1 - WX655/WP599 OIL PLUG FOR ARM
1 - WX655/WH482 STRIP FOR MAIN BODY

WX655/WP771	NUT FOR CANTING LOCK
WX655/WP772	STOP PLATE FOR CANTING LOCK
WX655/WP773	HANDWHEEL CLUTCH PLATE
WX655/WP774	LOCKNUT FOR WROMSHAFT
WX655/WP775	LOCKING HANDLE
WX655/WP779	SUPPORT ROD FOR FREQUENCY CHANGER
WX655/WP780	LOCK BUSH
WX655/WP781	LOCK BUSH
WX655/WP782	LOCKING SCREW
WX655/WP783	SHAFT FOR CANTING LOCK
WX655/WP786	COVER FOR COLUMN
WX655/WP790	PLATE FOR MOTOR LUBRICATORS
WX655/WP840	MOTOR BRACKET (FRONT)
WX655/WP841	MOTOR BRACKET (REAR)
WX655/WP907	SHAFT FOR MANUAL RISE AND FALL OF ARM
WX655/WP909	END CAP FOR BEARING
WX655/WP910	BRACKET FOR ELEVATING HANDWHEEL SHAFT
WX655/WP911	COVER OVER UNIVERSAL JOINT
WX655/WH44/A	HANDWHEEL FOR FEED CONTROL SHAFT
WX655/WH482	STRIP FOR MAIN BODY
WX655/WH489	STRIP FOR MAIN BODY
WX655/WH490	STUD FOR TAPER GIB STRIP
WX655/WH491	TAPER GIB STRIP FOR ARM
WX655/WH493	STUD FOR MOTOR LUBRICATOR PLATE
WX655/FC1006	LIP FOR L.S.S. CHIPBREAKER
WX655/MT1	TURNTABLE
WX655/RJ115	SPRING
WX655/M & E.3	HARDY UNIVERSAL COUPLING.

WX654/WP748	GUARD FOR SPINDLE DRIVE
WX654/WP751	COLLAR FOR ROTOR SPINDLE
WX654/WP757	LOCKING STUD
WX654/WP758	LOCKING COLLAR
WX654/WP759	LEVER FOR BARREL LOCK
WX654/WP760	SPACING SLEEVE
WX654/WP784	GUARD FOR SPINDLE DRIVE
WX654/WH451	BRASS SCALE FOR ARM
WX654/WH473	ARM PLUNGER HOLE BUSH
WX654/AC24	PLUNGER BRACKET
WX654/NQ103	LOCKNUT FOR RACK PINION SLEEVE
WX654/PK191	PLUNGER FOR SWIVEL FENCE
WX654/QV3	OIL HOLE COVER
WX654/SKF1208	BEARING
WX654/SKF2207	BEARING
WX654/SKF6209	BEARING
WX654/SKFRLS10	BEARING
WX654/R&M LDJT 50	BEARING
WX654/1	HORN HANDLE
WX654/2A	PLUNGER CAP
WX654/2A	PLUNGER LEVER
WX654/2C	BALL BEARING LOCKNUT
WX654/3	SPRING
WX654/3A	BALL BEARING LOCKNUT
WX654/4A	PLUNGER
WX654/91	GREASE RETAINER
WX654/92	GREASE RETAINER

WX683/WP844	CARRIAGE
WX683/WP845	CENTRAL PILLAR FOR TABLE BODY
WX683/WP856	TRAVERSE HANDWHEEL SHAFT
WX683/WP860	BARREL LOCK END CAP
WX684/WH217	$\frac{1}{2}$ " LOCKING SCREW
WX684/WH277	LOCKING PAD
WX684/WH301/B	TABLE SLIDE
WX684/WH311	PLUNGER BRACKET FOR CARRIAGE SLIDE
WX684/WH312	PLUNGER BRACKET FOR CARRIAGE SLIDE
WX684/WH325	CLAMP BLOCK FOR TABLE BODY
WX684/WH330	PLUNGER STOP FOR TABLE SLIDE
WX684/WH335	RAILS
WX684/WH343	ADJUSTABLE PLUNGER BRACKET
WX684/WH403	STOP BAR FOR TABLE SLIDE
WX684/WH415	STOP BAR FOR CARRIAGE
WX684/WH429	CROSS TRAVERSE SCREW
WX684/WH439	SHAFT FOR TABLE ROLLERS
WX684/WH440	LOCKING ROD FOR TABLE BODY
WX684/WH445	SPROCKET WHEEL FOR TABLE BODY 14T $\frac{5}{8}$ "P
WX684/WH482	STRIP FOR MAIN BODY
WX684/WH489	STRIP FOR MAIN BODY
WX684/WH498	FACE STRIP FOR TABLE SLIDE
WX684/WP570/A	ELEVATING SCREW
WX684/WP573	WASHER FOR ELEVATING SCREW
WX684/WP574	LOCKNUTS FOR ELEVATING SCREW
WX684/WP575	LOCKNUTS FOR ELEVATING WORMWHEEL
WX684/WP576	COLLAR FOR ELEVATING SCREW
WX684/WP716	BRACKET FOR ELEVATING SCREW
WX684/WP724	WORMWHEEL FOR RAISING MOTION
WX684/WP801	TABLE

WX684/WP803	CARRIAGE SLIDE
WX684/WP804	HANDWHEEL BRACKET FOR CARRIAGE SLIDE.
WX684/WP806	BEARING FOR TABLE SCREW
WX684/WP807	BEARING FOR TABLE SCREW
WX684/WP810	BARREL LOCKING SHAFT
WX684/WP819	SCRAPER PLATE
WX684/WP820	GUIDE BLOCK FOR TABLE BODY
WX684/WP821	DEAD STOP FORT TABLE CARRIAGE
WX684/WP826	MAIN COLUMN
WX684/WP851/A	TABLE BODY
WX684/WP852	HANDWHEEL BRACKET
WX684/WP857	BARREL PLUNGER FOR TABLE BODY.
WX684/WP853	BUSH FOR TABLE BODY PLUNGER
WX684/WP861	LOCKING HANDLE GLAND
WX684/NHG42	POINTER
WX684/WK108	SLOTTED SLEEVE
WX684/11B	PLUNGER

WX655/9	COLLAR
WX655/52A	VEE BELT
WX655/M & B No.2.	
WX655/COMPO SN011	BUSH
WX655/COMPO SN475	BUSH
WX655/R & M LJT	BEARING 1 $\frac{3}{8}$ "
WX655/R & M LJT	BEARING 2 $\frac{1}{4}$ "
WX655/SKF020	BEARING
WX655/SKF RLS 8	BEARING
WX683/WH302	CENTRE PLATE FOR TABLE
WX683/WH306/A	SLIDE STRIP FOR TABLE SLIDE
WX683/WH309	TABLE SCREW BRACKET FOR CARRIAGE FRAME
WX683/WH318	12" SPECIAL HANDWHEEL FOR TABLE CONTROL
WX683/WH319	6" SPECIAL HANDWHEEL FOR TABLE CONTROL
WX683/WH320	CONTROL PINION FOR TABLE SCREW
WX683/WH342	PLUNGER BRACKET FOR TABLE
WX683/WH347	SPIRAL GEAR BRACKET
WX683/WH353	FIXED GUIDE BLOCK FOR TABLE BODY
WX683/WH400	LEVER FOR TABLE
WX683/WH402	ADJUSTING NUT FOR PLUNGER
WX683/WH406	LONGITUDINAL FEED SCREW
WX683/WH407	LOCKNUT FOR LONGITUDINAL FEED SCREW
WX683/WH409	THRUST COLLAR FOR LONGITUDINAL FEED SCREW
WX683/WH419	SPIRAL GEAR
WX683/WH420	SPIRAL GEAR SHAFT
WX683/WH424	ROLLER FOR TABLE BODY
WX683/WP808	BARREL LOCK BUSH
WX683/WP809	BARREL LOCK BUSH
WX683/WP811	NUT FOR BARREL LOCK
WX683/WP817	BEVEL GEAR
WX683/WP818	LOCKING HANDLE GLAND.
WX683/WP822	

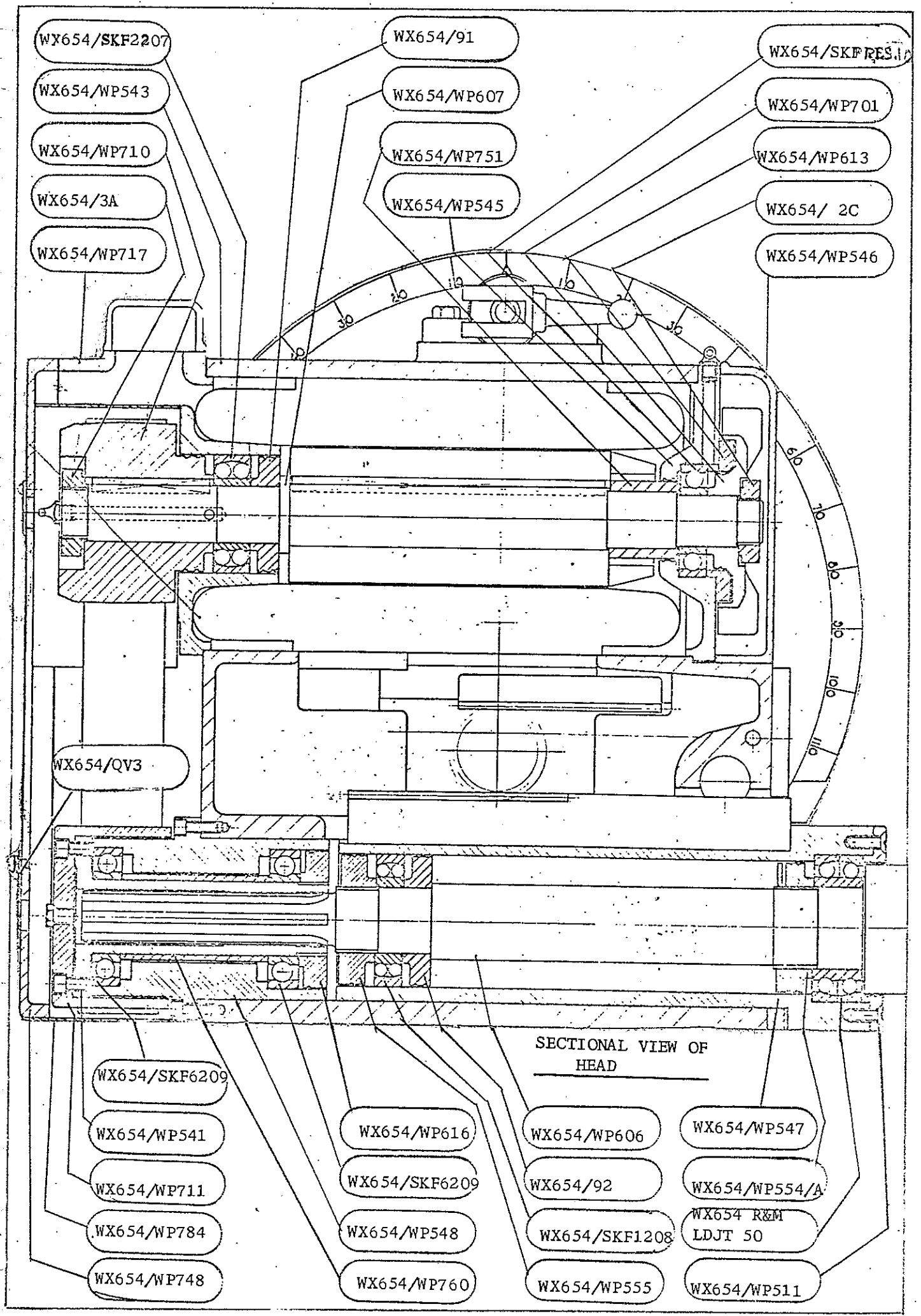

WX654/SKF2207

WX654/91

WX654/SKFPRES.1

WX654/WP543

WX654/WP607

WX654/WP701

WX654/WP710

WX654/WP751

WX654/WP613

WX654/3A

WX654/WP545

WX654/ 2C

WX654/WP717

WX654/WP546

WX654/QV3

SECTIONAL VIEW OF
HEAD

WX654/SKF6209

WX654/WP616

WX654/WP606

WX654/WP547

WX654/WP541

WX654/SKF6209

WX654/92

WX654/WP554/A

WX654/WP711

WX654/WP548

WX654/SKF1208

WX654 R&M
LDJT 50

WX654/WP784

WX654/WP760

WX654/WP555

WX654/WP511

WX654/WP748

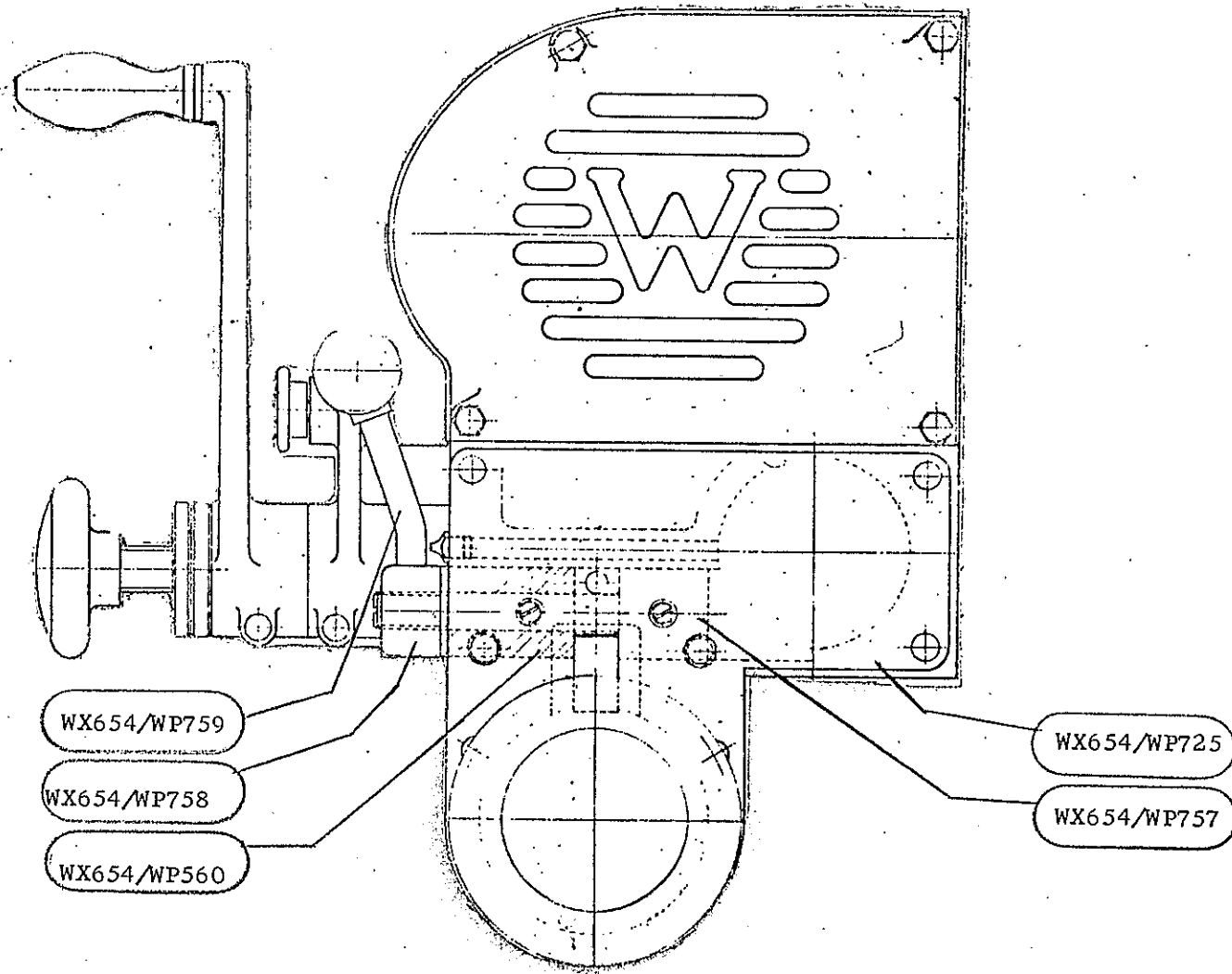

END ELEVATION OF WX HEAD

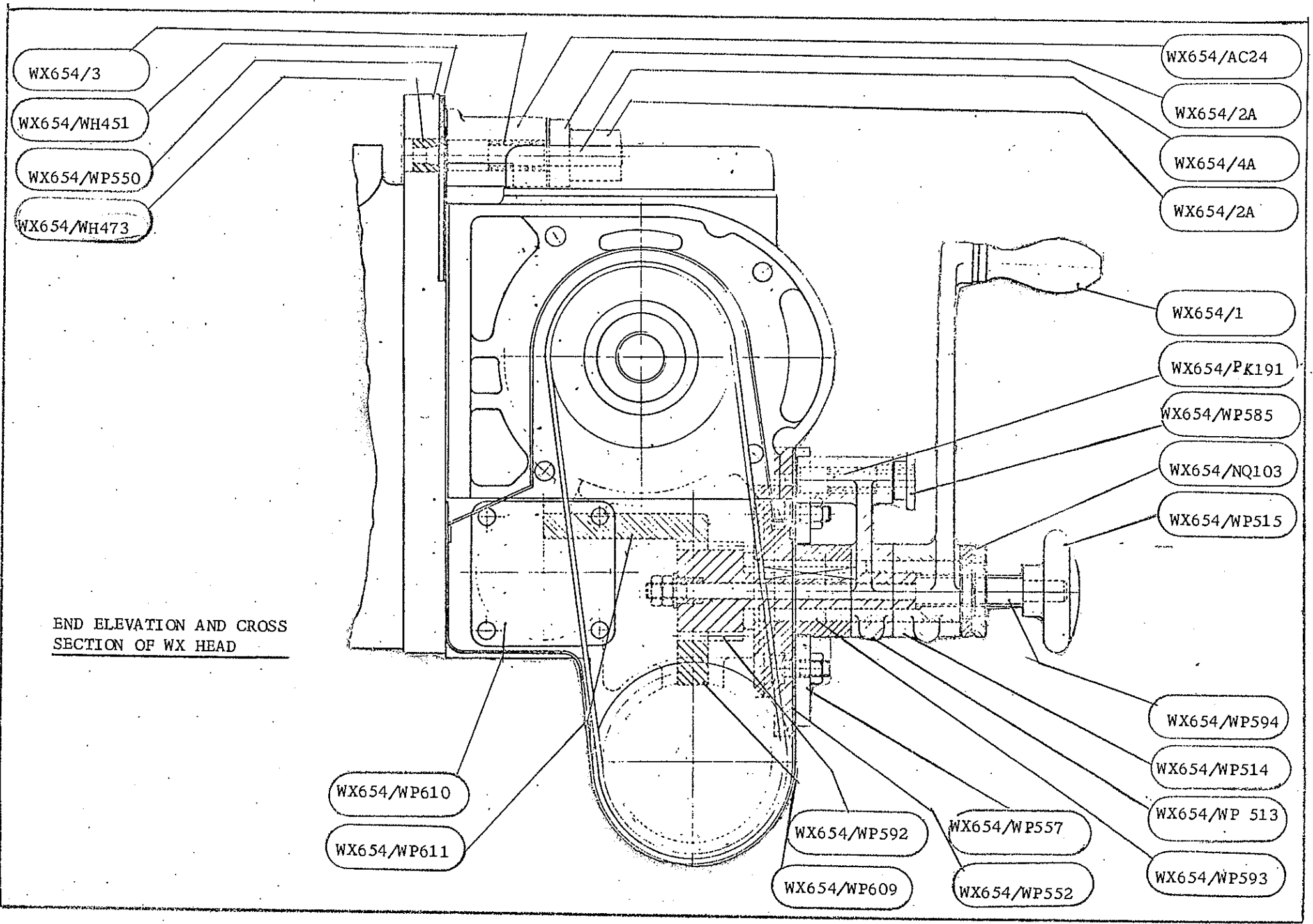

- WX654/3
- WX654/WH451
- WX654/WP550
- WX654/WH473

- WX654/AC24
- WX654/2A
- WX654/4A
- WX654/2A

- WX654/1
- WX654/PK191
- WX654/WP585
- WX654/NQ103
- WX654/WP515

END ELEVATION AND CROSS SECTION OF WX HEAD

- WX654/WP610
- WX654/WP611

- WX654/WP592
- WX654/WP609
- WX654/WP557
- WX654/WP552

- WX654/WP594
- WX654/WP514
- WX654/WP 513
- WX654/WP593

WX684/
WP 574

WX684/
WP 573

WX684/
WP 576

WX684/
WP 724

WX684/
WH 489

WX684/
WP 826

WX684/
WP 716

WX684/WP570/A

WX 684/
WP 575

WX 684/
WH 482

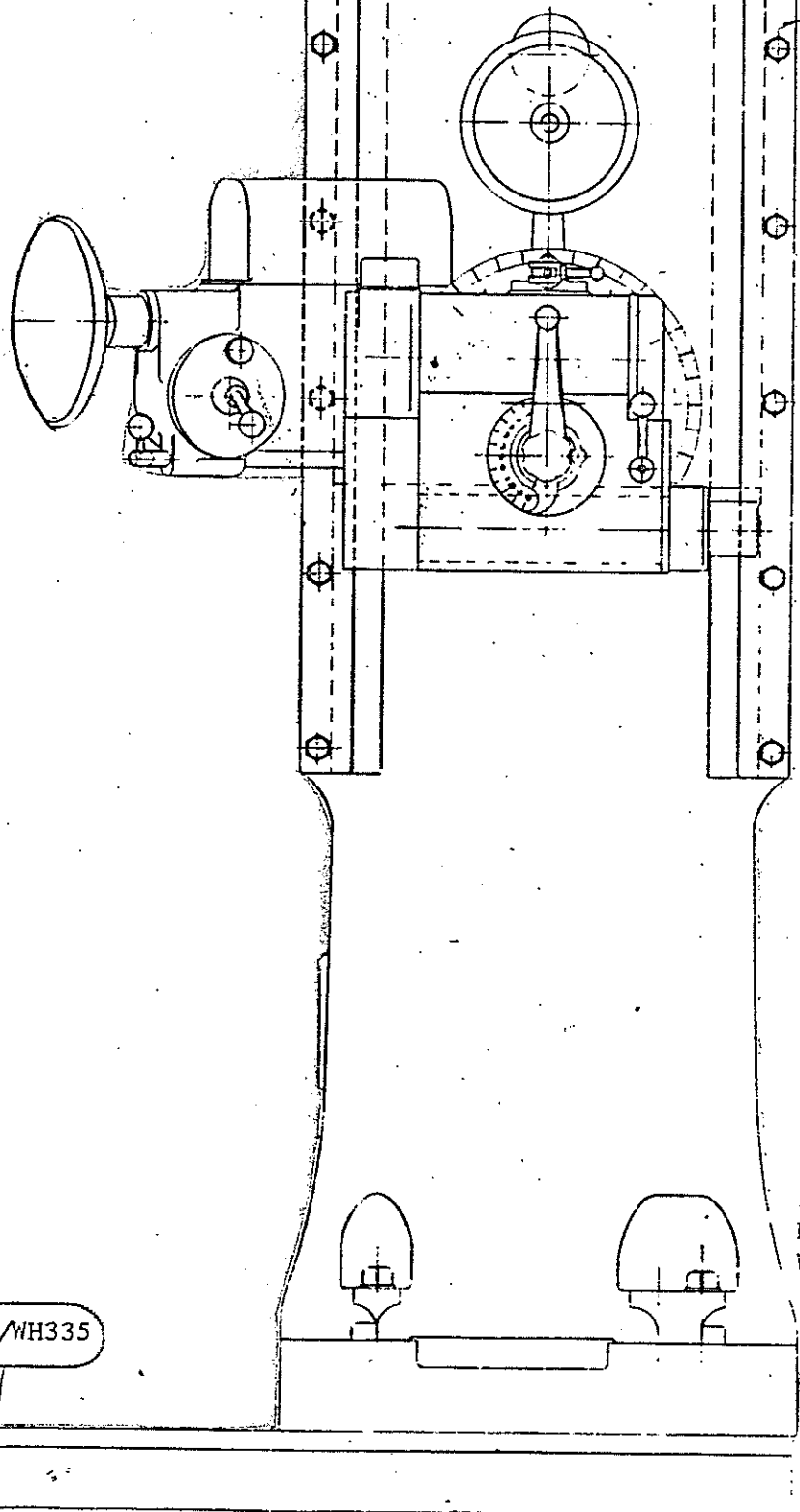

WX684/WH335

FRONT VIEW OF
MAIN BODY ON
WX MACHINE.

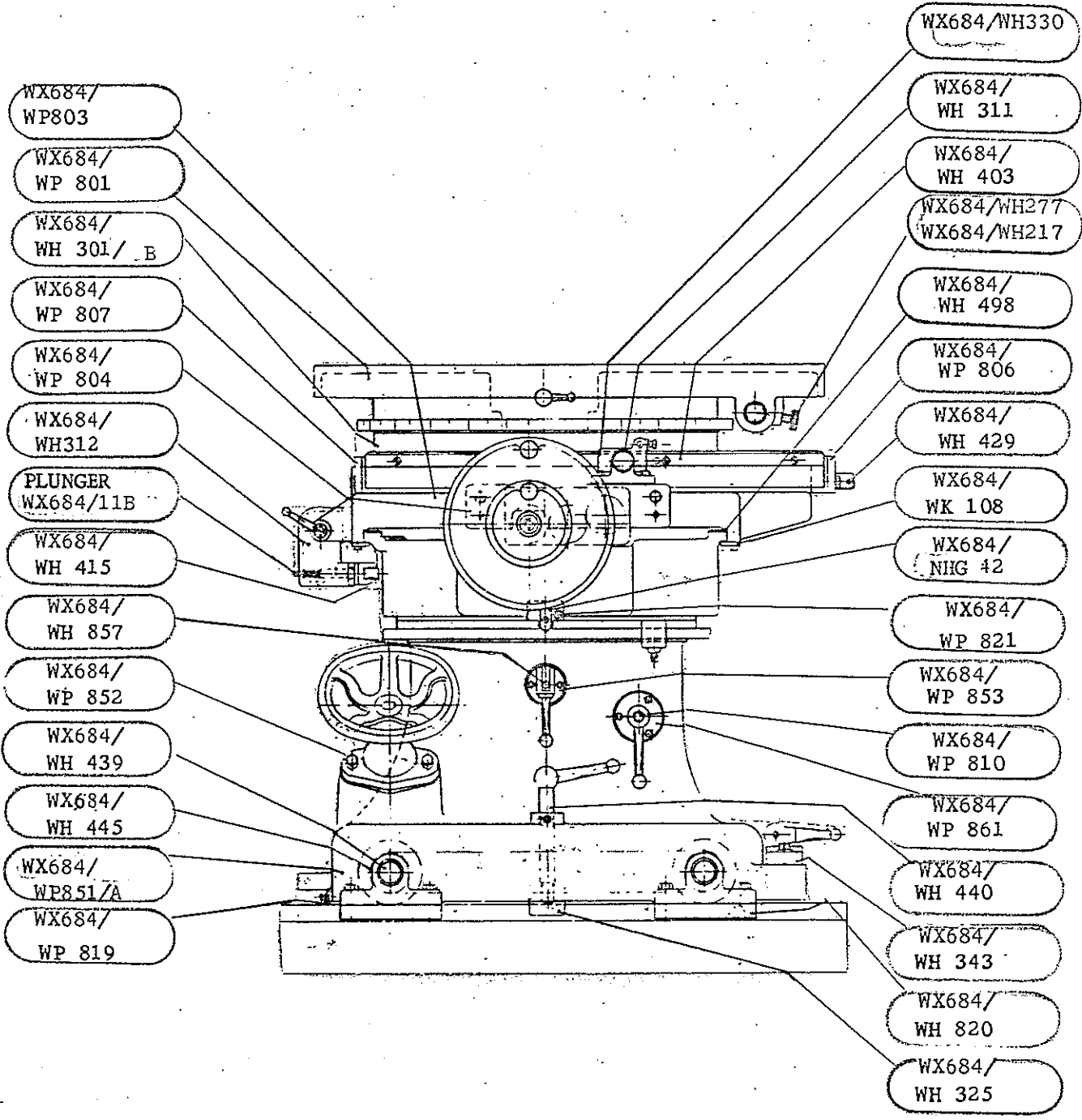

FRONT ELEVATION OF TABLE ON PATTERN MILLER WX.

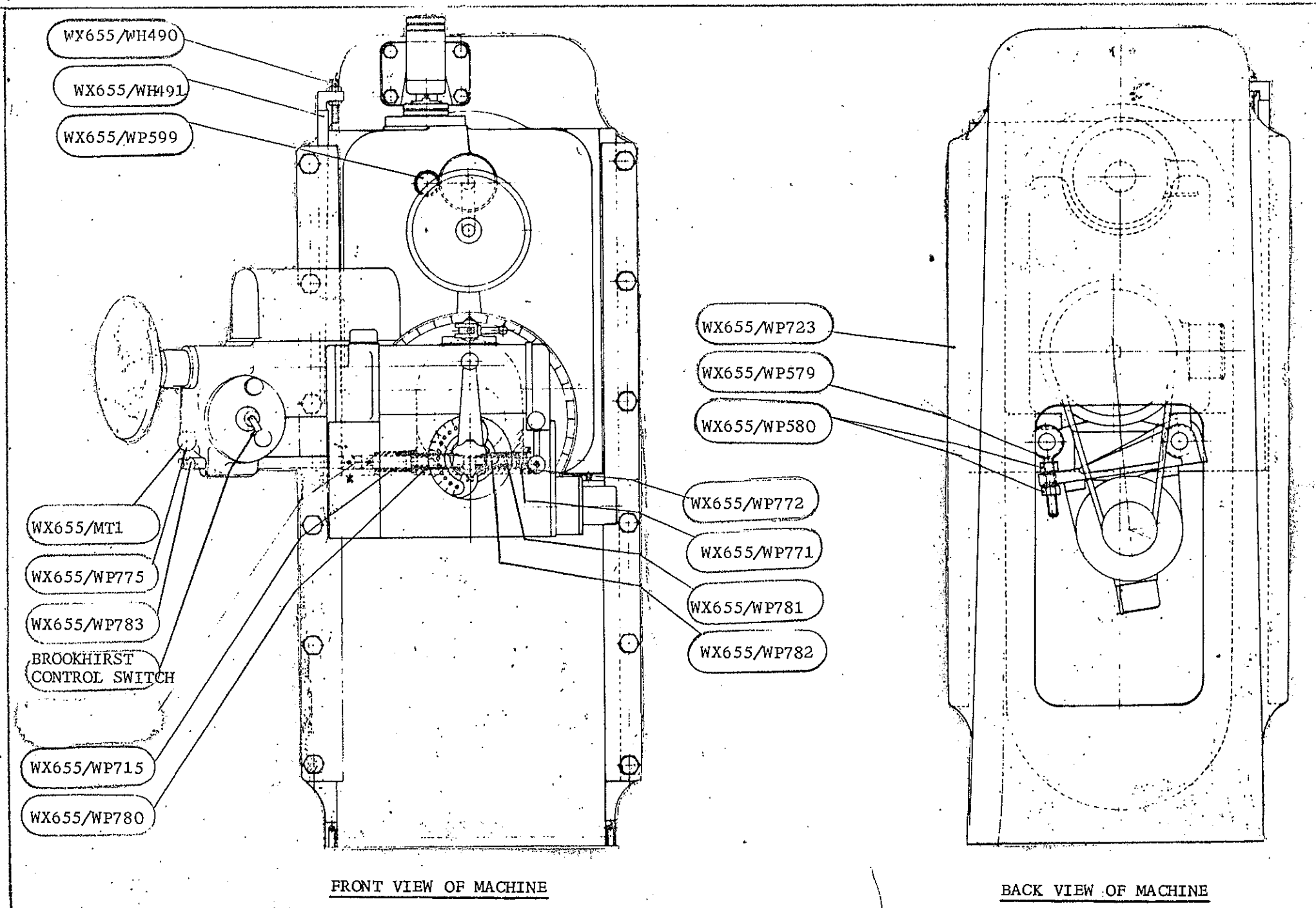

FRONT VIEW OF MACHINE

BACK VIEW OF MACHINE

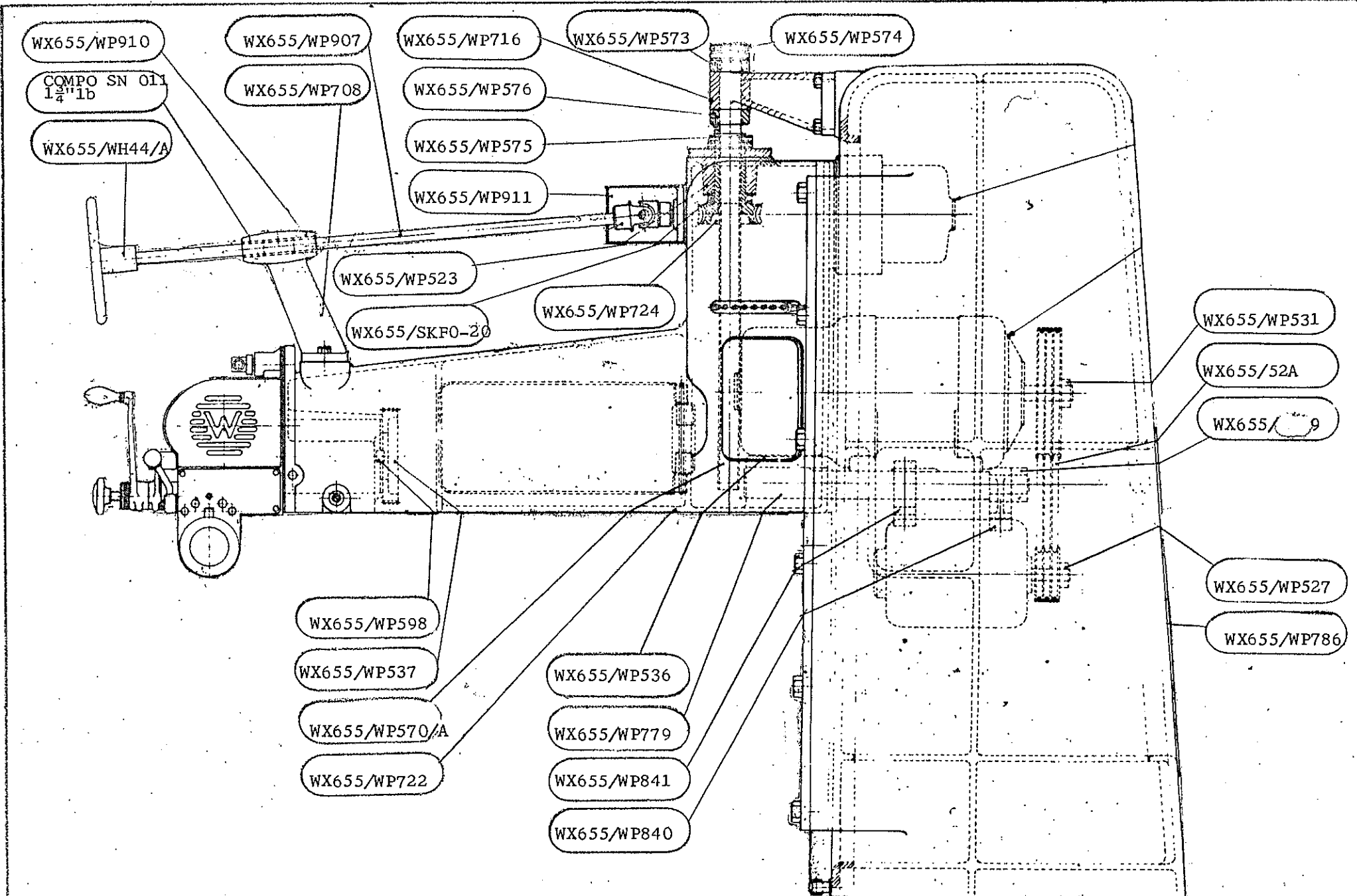

END ELEVATION

SIDE ELEVATION OF WX PATTERN MILLER.

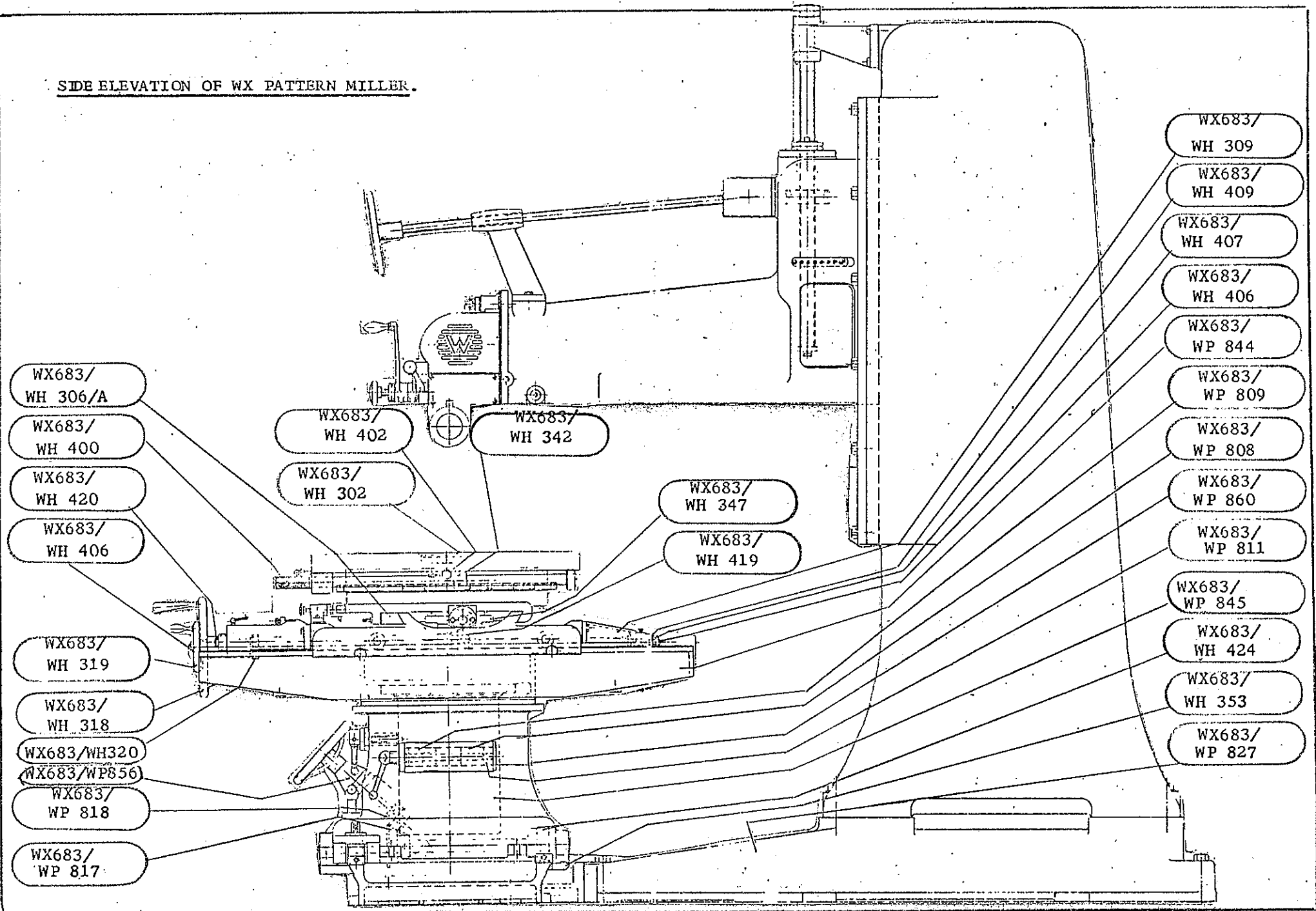

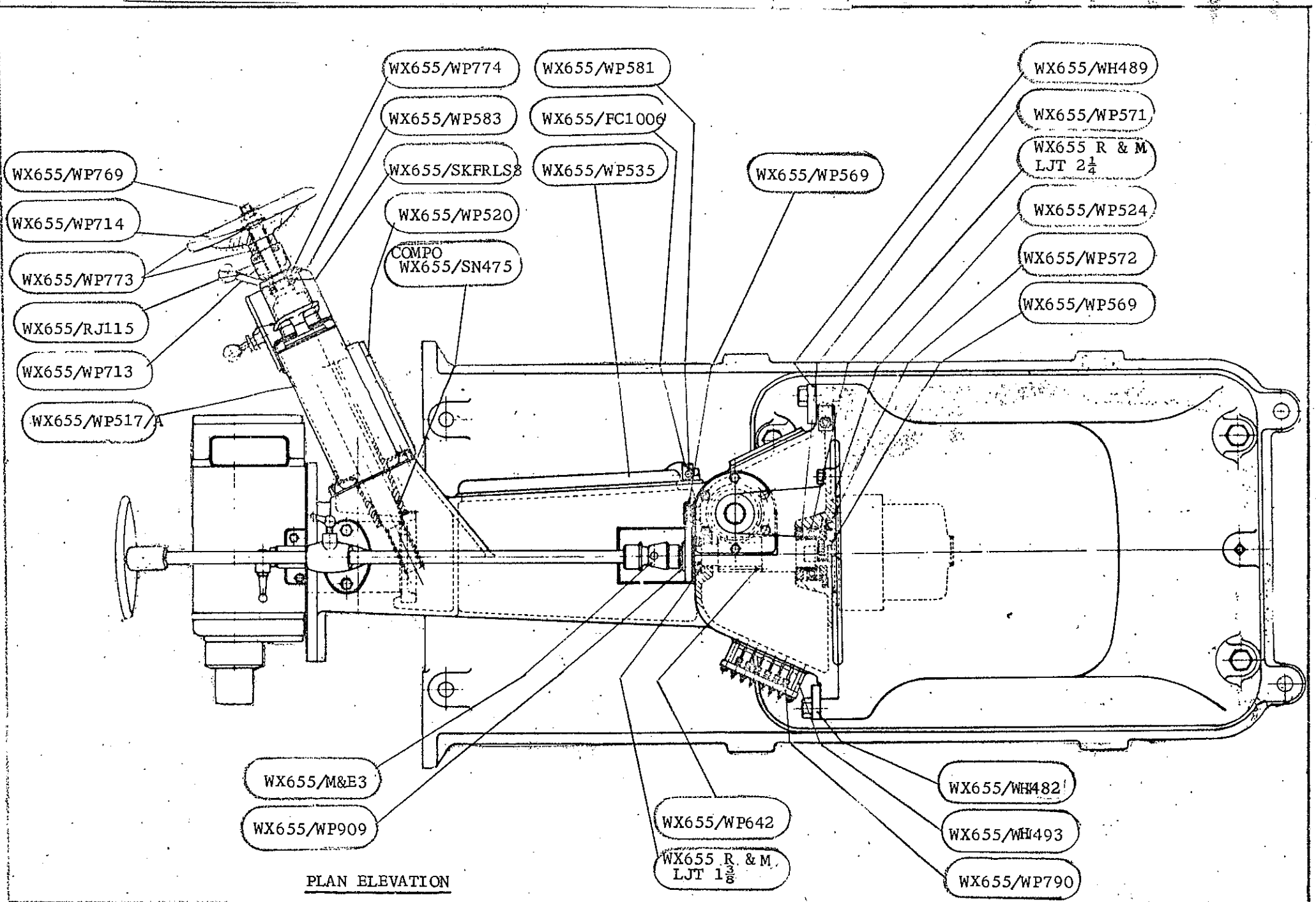

PLAN ELEVATION