



ULTRACARE
At the Cutting Edge of Industry

RS

WOOD TURNING LATHE

(6", 8" AND 10")

INSTRUCTION MANUAL No.908

Wadkin

WOOD TURNING LATHES, TYPE R. S. (6", 8" AND 10")

PRINCIPAL DIMENSIONS AND CAPACITIES.

	6" R. S.		8" R. S.		10" R. S.	
	English	Metric	English	Metric	English	Metric
Height of centres	6 $\frac{1}{4}$ "	159mm	8 $\frac{1}{4}$ "	210mm	10 $\frac{1}{4}$ "	260mm
Will take between centres	3'6"	1067mm	5'6"	1676mm	7'6"	2286mm
Height from floor to centres	3'7"	1092mm	3'7"	1092mm	3'7"	1092mm
Width which can be turned with gap bed	12"	305mm	12"	305mm	12"	305mm
Diameter which can be turned with gap bed... ..	2'0 $\frac{1}{2}$ "	622mm	2'4 $\frac{1}{2}$ "	724mm	2'8 $\frac{1}{2}$ "	825mm
Diameter which can be turned over hand turning and travelling tool carriage ...	9"	229mm	13"	330mm	17"	432mm
On 50 cycles supply :-						
Speeds of spindle when provided with four speeds	240 - 600 - 1,250 - 2,880 r. p. m.					
Speed of motor for four speed machine	960 r. p. m.		960 r. p. m.		960 r. p. m.	
Speeds of spindle when provided with eight speeds	200, 320, 500, 750, 960, 1440, 1850, 2880 r. p. m.					
Speed of motor for eight speed machine	960 - 1,460 r. p. m.					
On 60 cycles supply :-						
Speeds of spindle when provided with four speeds	280 - 720 - 1,500 - 3,350 r. p. m.					
Speed of motor for four speed machine	1,200 r. p. m.		1,200 r. p. m.		1,200 r. p. m.	
Speeds of spindle when provided with eight speeds	240, 380, 600, 900, 1,150, 1,750, 2,220, 3,360 r. p. m.					
Speed of motor for eight speed machine	900 - 1,800 r. p. m.					
Horse power of motor	1 $\frac{1}{2}$		1 $\frac{1}{2}$		1 $\frac{1}{2}$	
Floor space	7'0" x 2'3"		9'0" x 2'3"		11'0" x 2'3"	
	2139mm x 686mm		2743mm x 686mm		3353mm x 686mm	
Net weight of standard machine in cwts.	12 $\frac{1}{4}$ (1372lbs) 622 kilos		13 $\frac{1}{4}$ (1484lbs) 673 kilos		15 $\frac{1}{4}$ (1708lbs) 774 kilos	
Shipping dimensions in cu. ft.	58 1.64 cu. m		61 1.73 cu. m		66 1.87 cu. m	

DETAILS INCLUDED WITH THE MACHINE.

Motor, control gear and driving belt.	One 2 $\frac{1}{4}$ " screw point driving centre.
One 6 $\frac{1}{2}$ " face plate.	One set of six assorted hand turning tools.
One hand rest complete.	One set of spanners.
Two dead centres.	Lubricating pump and tin of lubricant for
One 1 $\frac{1}{8}$ " four spur removable point driving centre.	ball bearings.

INSTALLATION.

The machine is despatched from the Works with all bright surfaces greased to prevent rusting. This protective covering should be removed by applying a cloth soaked in paraffin or turpentine.

FOUNDATIONS.

If the mill floor consists of 4" (102mm) solid concrete no special foundation is necessary. $\frac{5}{8}$ " (16mm) diameter rag bolts or plates and bolts should be used for fixing the machine to the floor, but these are not supplied by Wadkin Ltd. unless specially ordered. The outline in Fig. 1 gives details of bolt positions and clearances required. Cut 4" (102mm) square holes in the concrete and with bolts in position run with liquid cement to fix. Alternatively cawl plugs may be used. A good wooden floor is also satisfactory and coachscrews may then be used.

Place a spirit level lengthwise and crosswise across the surface of the bed using $\frac{1}{8}$ " (6mm) shims as necessary under the corners of the headstock and the legs supporting the bed, level the machine. When level secure the machine to the floor. After final fixing check the level again to ensure that no distortion has taken place.

WIRING.

For complete cabling instructions see end of book. Wiring diagram D. 1034 is for motors on 50 cycles and diagram D. 1035 for motors on 60 cycles supply.

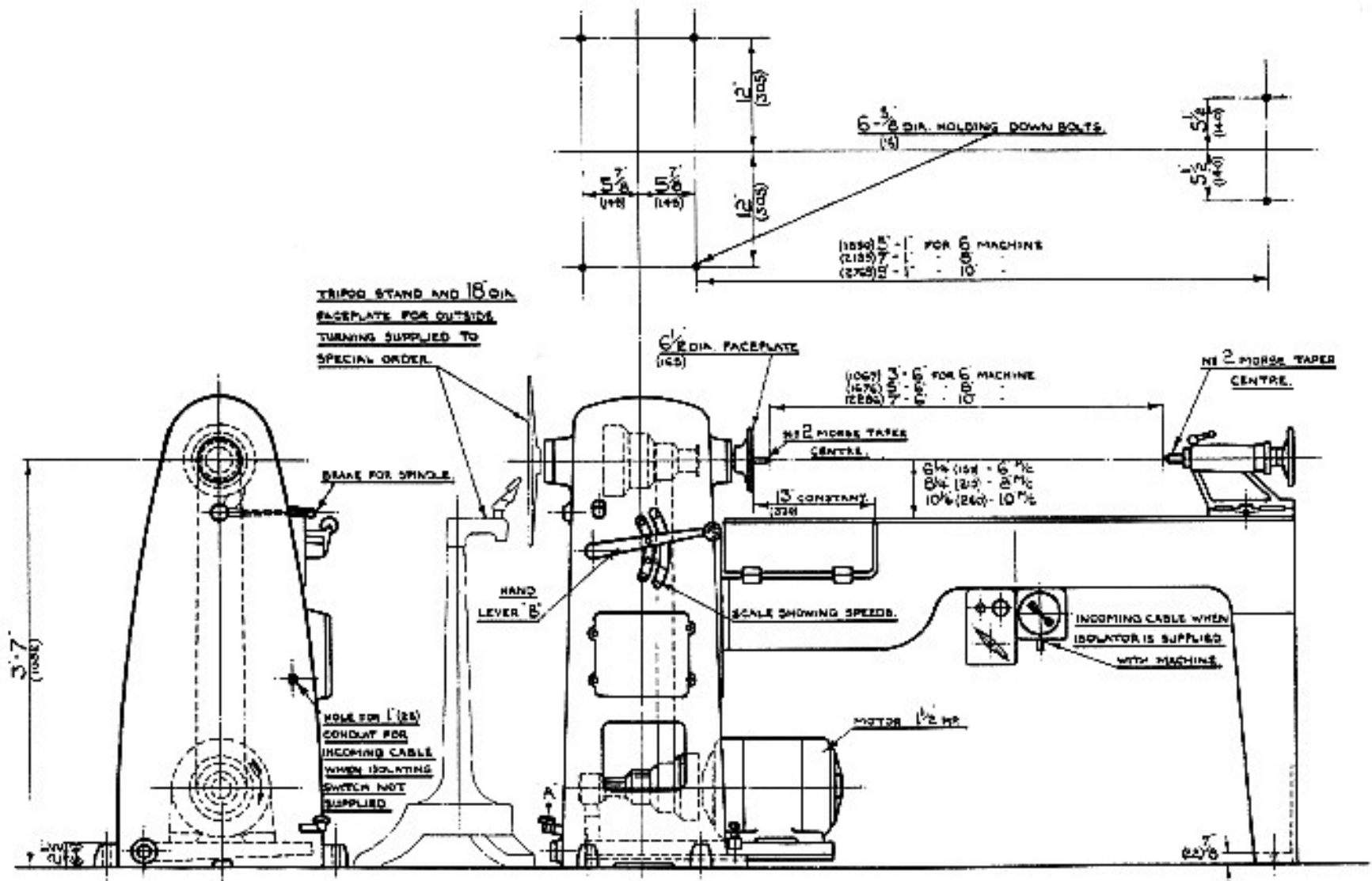

6", 8" OR 10" WOOD TURNING LATHE. - TYPE RS.

DIMENSIONS IN FEET, INCHES AND MILLIMETRES.

LUBRICATION

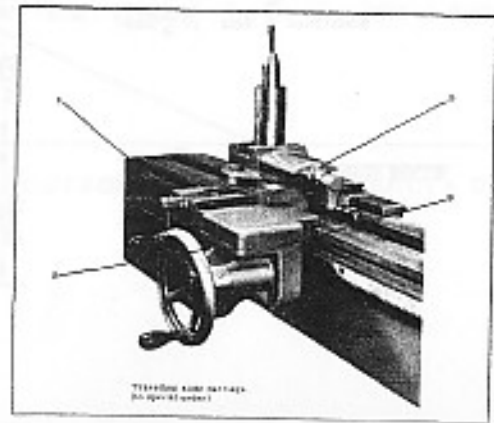
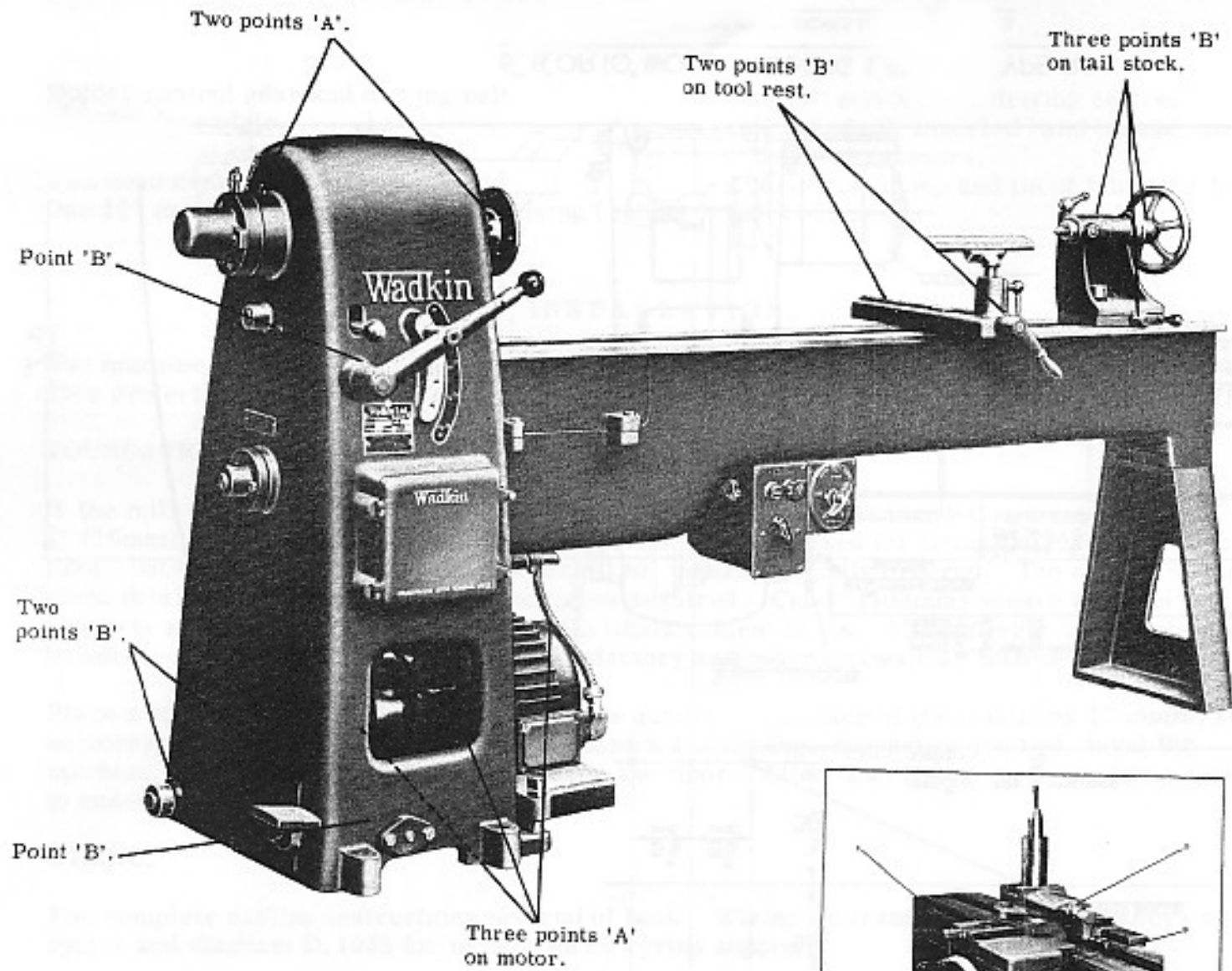

FIG. 2. GENERAL VIEW OF MACHINE.

LUBRICATION.

Every week thoroughly clean down the machine and renew the thin film of oil on all bright parts not in constant use to prevent rusting. The bed slide should also be oiled weekly.

The travelling slide carriage pinion, rack and gears should be oiled every month. Use Wadkin oil Grade L. 4.

A POINTS. Give three depressions of the grease gun every four months using Wadkin ball bearing grease Grade L6.

B POINTS. Oil twice weekly with Wadkin oil Grade L4.

WADKIN RANGE OF OIL AND GREASE LUBRICANTS WITH EQUIVALENTS.

Wadkin Grade	EQUIVALENT LUBRICANTS.		
	Shell Mex and B. P. Ltd.	Mobil Oil Co. Ltd.	Caltex Lubricants.
Machine Oil Grade L. 4.	Shell Vitrea Oil 33	Mobil "Vactra" Oil (Heavy Medium)	Caltex Aleph Oil.
Ball Bearing Grease Grade L. 6.	Shell Nerita Grease 3	Mobilux Grease No. 2.	Regal Starfak No. 2 Grease.

BALL BEARING LIST

Maker's Number	Size			Number Per Machine	Where used on Machine
	Bore	Outside Diameter	Width		
SKF. RLS. 13F	1 ⁵ / ₈ "	3 ¹ / ₂ "	³ / ₄ "	1	Headstock spindle. Front } For machines up to No. 1625
SKF. RLS. 13	1 ⁵ / ₈ "	3 ¹ / ₂ "	³ / ₄ "	1	
HOFF. N. 2768	45mm	85mm	38mm	1 pair	Headstock spindle. Front } For machines No. 1626 and future.
HOFF. R. 145	45mm	85mm	19mm	1	
SKF. RM. 9F	1 ¹ / ₈ "	2. 13/16"	13/16"	1	Motor support.

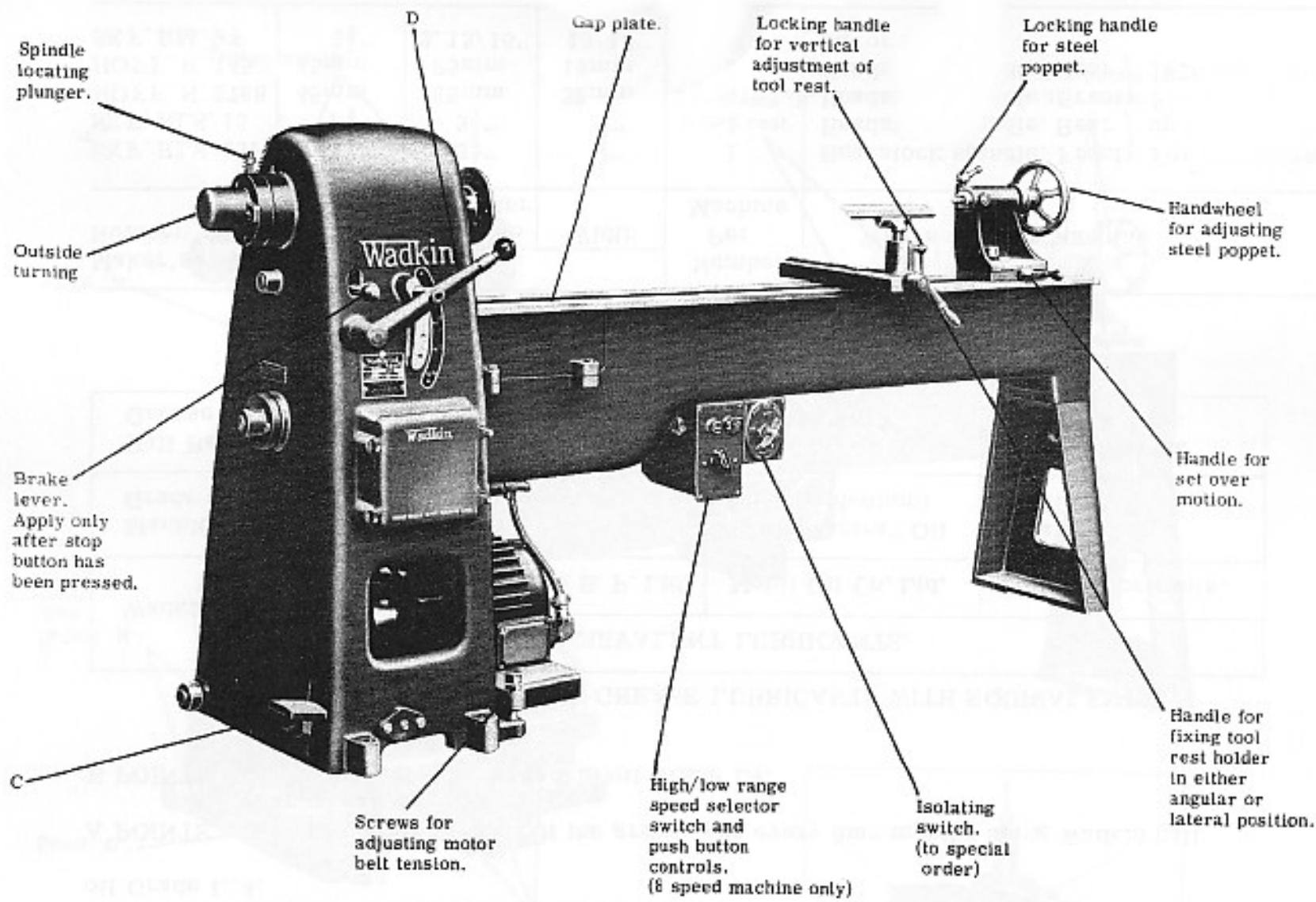

FIG. 3. GENERAL VIEW OF MACHINE.

THE BED

The bed has a gap plate as shown in Fig. 3 which lifts out when it is desired to turn large diameters of work on the bed side.

THE HEADSTOCK

The spindle is screwed at the front to receive face plates, and bored out Morse taper to take driving centres. It is also extended and screwed at the back to receive face plates for turning large work. Either four or eight speeds are provided as required. The speed of the spindle is changed by depressing the foot lever 'C' Fig. 3 which slackens the belt, and by moving the hand lever 'D', the belt is moved over to the various steps of the cone pulley. Spindle speeds are dependent on the diameter and length of stock, and the properties of the timber.

A locating plunger illustrated in Fig. 3 is used to lock the spindle when face plates or centres are being fitted or removed.

NOTE : Care must be taken to remove the plunger before putting the machine to use.

THE TAILSTOCK

The tailstock is bored out and fitted with a long steel poppet controlled by a large handwheel and square thread screw. The front end of the poppet is bored out Morse taper the same size as the headstock spindle. Self-discharging centres are fitted. Taper turning can be carried out as the tailstock is arranged with a setover motion by screw and handle.

THE TOOL REST HOLDER

The tool rest holder can be fixed in any desired angular or lateral position along the bed by eccentric lever handle. Adjustment in the height of the tool rest can be made to give the best possible position to the turning tool. Generally the height of the tool rest is slightly below the centres with the cutting edge of the tool in line with the centres. For some larger diameters of work up to 15" it may be advantageous to have the tool rest above the centres so that the tool can be held with its cutting edge tangential to the circumference of the work.

ACCESSORIES FOR USE ON WOOD TURNING LATHES, TYPE R. S.

NOTE

All the accessories shown on pages 8 to 14 are optional extras and only the items indicated on page 2 are included with the machine.

OUTSIDE TURNING

Where the work is too large to be turned between the head and tailstock, this attachment is used.

It consists of a tripod stand carrying a universal adjustable hand tool rest. The stand is designed with a large machined base in order that it may be placed in any position without bolting down.

An 18" diameter accurately balanced face plate is included and provided with holes for securing the work.

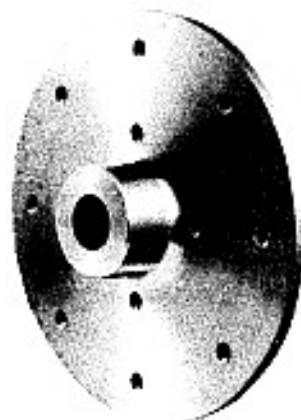
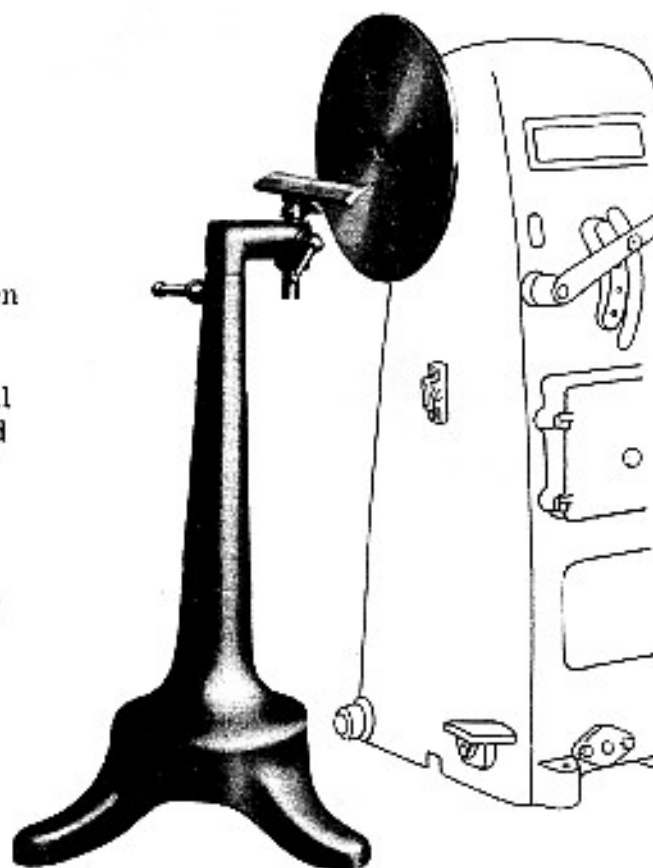

FACE PLATES

These are made from special material, machined all over and accurately balanced. A number of holes are drilled in the face for securing the work by means of wood screws. When ordering state which end of the lathe spindle the face plate is to fit whether it is to work on the bed side or on the opposite end for outside turning.

Diameter for Inside Turning	4"	6 $\frac{1}{2}$ "	8 $\frac{1}{2}$ "	10 $\frac{1}{2}$ "	12"	18"	-
Diameter for Outside Turning	-	-	-	-	12"	18"	24"

ACCESSORIES FOR USE ON WOOD TURNING LATHES, TYPE R. S. (Continued)

SINGLE TEE TOOL REST

For use when carrying out ordinary hand turning operations. It is used in conjunction with the holder illustrated below. The rest itself is in steel and is supplied in various lengths. The shank is also of steel and 1.1/8" diameter.

When ordering state the size of lathe for which the rest is required.

Length of Rest 6" 12" 16" 20"



DOUBLE TEE TOOL REST

This is similar to the single type described but it is extra long for turning long lengths by hand. It is rigidly held by using two holders. One extra holder is included to accommodate the additional stem. When ordering state size of lathe for which rest is required.

Length of Rest 24" 30" 36" 42"



ANGLE TOOL REST

On certain classes of work this type of Rest is extremely useful and can be supplied additional to those described above. It is made in two sizes with 2" and 6" long arms each at right angles to one another.

When ordering give size of machine.



HAND TOOL REST HOLDERS

There are simple yet very effective holders for taking tool rests shown above. The one opposite can be fixed in any desired position on the lathe bed by a locking plate actuated by eccentric lever handle, and is available for the 6", 8" and 10" lathes. With order please state size of lathe. An appropriate rest is included with the machine.



TOOL REST FOR USE WHEN GAP PIECE IS REMOVED

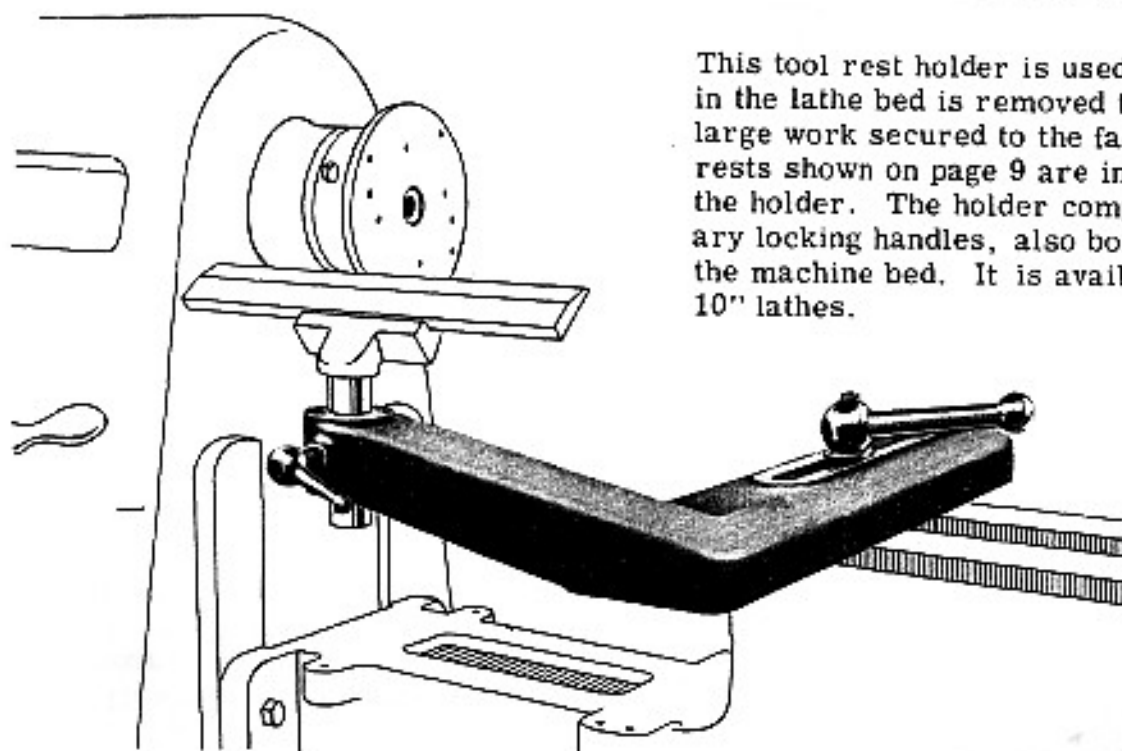

This tool rest holder is used when the gap piece in the lathe bed is removed to permit turning large work secured to the face plate. The tee rests shown on page 9 are interchangeable in the holder. The holder comprises the necessary locking handles, also bolt for securing to the machine bed. It is available for 6", 8" and 10" lathes.

STEADY REST

When turning long work at speed oscillation takes place. This can be eliminated by using a steady rest and running at a lower speed. The steady rest shown has wooden contact pieces to prevent damage to the article turned.

The centre hole in the steady is $6\frac{1}{2}$ " diameter.

With order please give size of lathe.

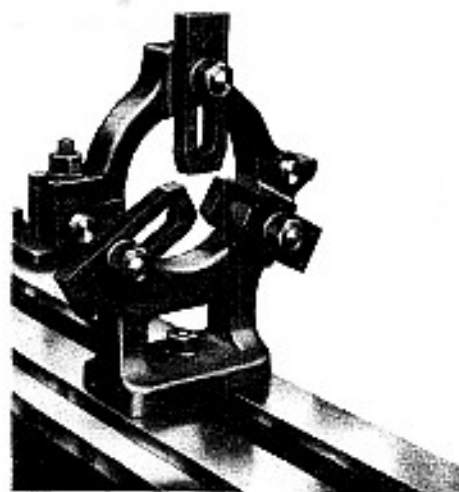

ACCESSORIES FOR USE ON WOOD TURNING LATHES,
TYPE R. S. (Continued)

CONICAL CENTRES

These are supplied in pairs, one for the driving headstock and one for the tailstock. They are of tempered steel and accurately ground with No. 2 Morse taper shanks.

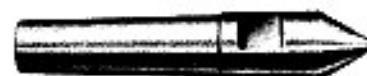

Conical Centres

FOUR SPUR DRIVING CENTRES

These are made with four spurs and centre points. They are of tempered steel and accurately ground with No. 2 Morse taper shanks. Three sizes are available $\frac{3}{4}$ ", $1\frac{1}{8}$ " and $1\frac{1}{2}$ ".



Four Spur Driving Centres

CUP CENTRES

These are similar to those above with the exception that they are circular in shape. Available in $\frac{1}{2}$ " and $\frac{3}{4}$ " sizes.



Cup Centres

SCREW POINT DRIVING PLATE

This plate is used when turning small pieces which cannot be held between the conical centres. The centre of the plate is drilled to take an ordinary wood screw which is operated through a hole in the shank, and holes are also drilled in the plate for securing the work. It is provided with a No. 2 Morse taper shank to fit into the driving headstock. Two sizes are available with the driving plate either 2.1/4" or 3.1/2" diameter.



Screw Point Driving Plate

REVOLVING CENTRE, MODEL DB

It is sometimes found that the ordinary type of fixed centre in the tailstock gives trouble. To obviate this difficulty the use of the special type of work carrier with a "revolving" centre is recommended. The centre spindle is mounted on ball bearings which are arranged to take the thrust load. The shank is accurately ground No. 2 Morse taper to fit the tailstock spindle. Overall length is $5\frac{3}{16}$ " with the body $1\frac{13}{16}$ " diameter.



Revolving Centre, Model DB

ACCESSORIES FOR USE ON WOOD TURNING LATHES, TYPE R. S. (Continued)

TRAVELLING SLIDE TOOL CARRIAGE

The travelling slide tool carriage as illustrated can be supplied when required. It is provided with lateral and cross motions and is traversed along the lathe bed by a handwheel engaging a steel rack and pinion. The tool post is mounted on a graduated swivel slide to enable angular and taper work to be done. The tool post is slotted to receive turning tools and suitable spacing collars are provided. Adjustable spherical spacing collars permit the tool being adjusted to the correct angle for clean cutting.

6" Centre Lathe.	Will turn 9" diameter.
8" " "	" " 13" "
10" " "	" " 17" "

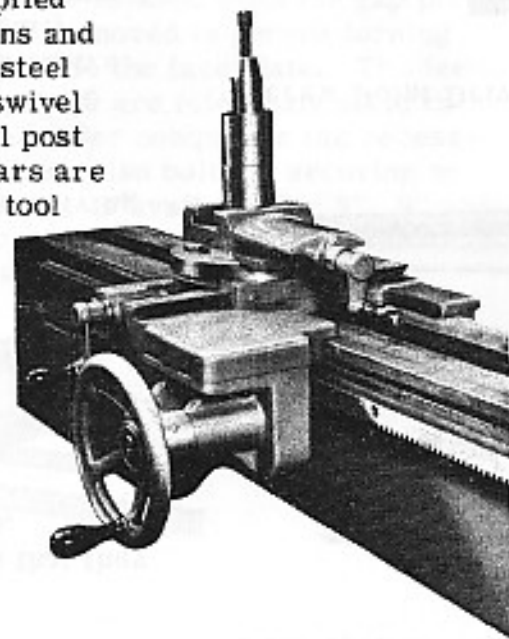

TURNING TOOLS FOR TRAVELLING SLIDE CARRIAGE

This set of tools has been specially prepared for use in the Travelling Slide Carriage and between them cover practically every job that can be done with the carriage. They are made from solid steel of the most suitable grade for wood turning. The shank is 1" x $\frac{1}{2}$ " thick.

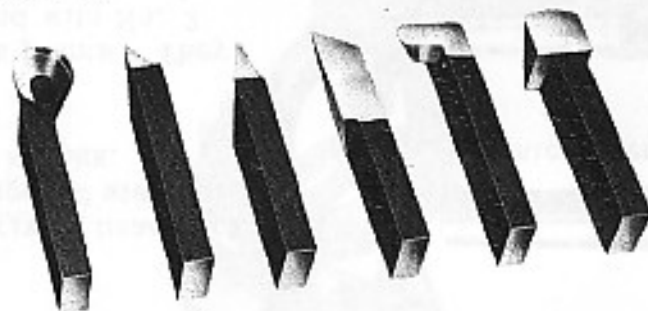

ACCESSORIES FOR USE ON WOOD TURNING LATHES, TYPE R. S. (Continued)

IMPROVED TOOL HOLDER

This adaptable device makes possible the use of ordinary hand turning tools in conjunction with the Travelling Slide Carriage. The holder is fixed in the slot in the tool post and effectively holds the tool at any angle. The shank is $\frac{1}{2}$ " thick.

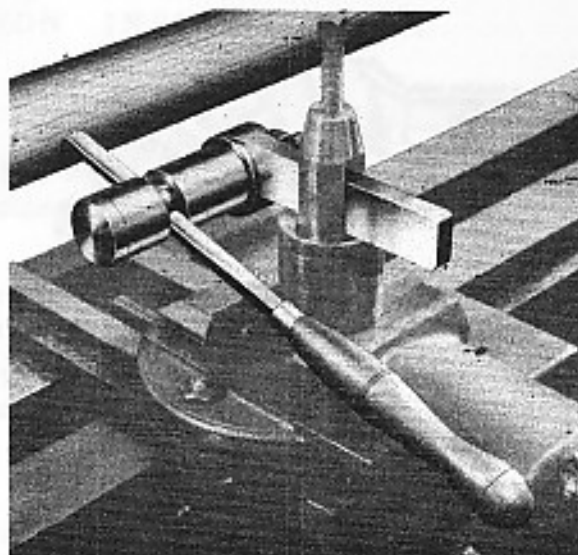

HAND TURNING TOOLS

Given below are a range of Turners' Tools suitable for all classes of turning operations. They are made from best quality cast steel and fitted with turned and polished wood handles.



CAST STEEL TURNING CHISELS



Widths with taper, round nose or diamond points

$\frac{1}{8}$ " , $\frac{1}{4}$ " , $\frac{3}{8}$ " , $\frac{1}{2}$ " , $\frac{5}{8}$ " , $\frac{3}{4}$ " , $\frac{7}{8}$ " , 1" , $1\frac{1}{4}$ " , $1\frac{1}{2}$ "

CAST STEEL V SHAPED TURNING TOOLS



$\frac{3}{8}$ " or $\frac{1}{2}$ " sizes

CAST STEEL TURNING GOUGES



Size .. $\frac{1}{8}$ " , $\frac{1}{4}$ " , $\frac{3}{8}$ " , $\frac{1}{2}$ " , $\frac{5}{8}$ " , $\frac{3}{4}$ " , $\frac{7}{8}$ " , 1" , $1\frac{1}{4}$ " , $1\frac{1}{2}$ "

CAST STEEL PARTING OFF TOOLS



$\frac{3}{4}$ " or 1" sizes

ACCESSORIES FOR USE ON WOOD TURNING LATHES, TYPE R.S. (Continued)

SCREW POINT CHUCK

Use a screw point chuck for rapidly centring small work, which is held by the taper screw. The further the work is screwed in the tighter it is held. The chuck is screwed internally to fit the headstock spindle.

Two sizes are available, 3" diameter and 4" diameter. When ordering please state size of lathe.



HOLLOW OR BELL CHUCK

A quick acting chuck which is bored with a taper hole to hold the work firmly. It is screwed internally to fit the headstock spindle.

The sizes given indicate the diameter of the hole to receive the work.

1" 1½" 2" 2½"

When ordering please give size of machine.

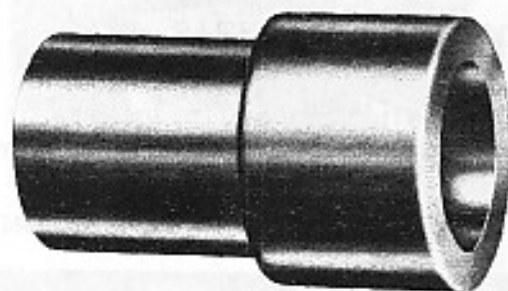

THREE OR FOUR JAW CHUCKS

Where aluminium or similar light non-ferrous parts are to be turned this chuck is provided. It is also suitable for holding such articles as wooden bowls etc.

A 4" three jaw self-centring geared chuck, as illustrated, can be supplied. Alternatively 4" or 6" chucks with four independent jaws can be supplied.

With order please give size of lathe.

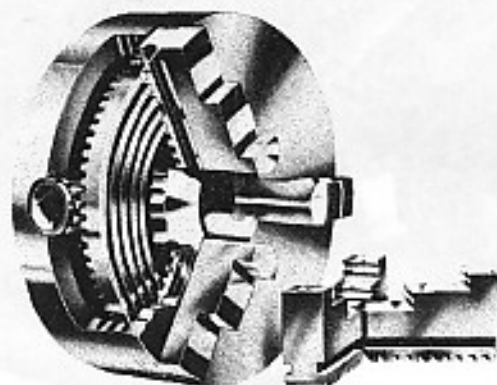

ELECTRICAL INSTALLATION INSTRUCTIONS.

The cabling between the motor and the control gear has been carried out by Wadkin Ltd. , and it is only necessary to bring the line leads to the machine for it to be put into service. This should be done as follows:

1. Fit triple pole isolating switch near the machine unless it has been supplied to special order by Wadkin Ltd. , when it will be fitted and connected to the machine.
2. Connect the line lead to the appropriate terminals. See diagram of connections. The cables should be taken to the machine in conduit and secured to the control gear by locknuts.
3. Connect solidly to earth.
4. Close isolating switch and press start button. If motor does not rotate in the correct direction, interchange any two incoming line leads.

FAILURE TO START.

1. Electric supply is not available at the machine.
2. Fuses have blown or have not been fitted.
3. Isolating switch has not been closed.
4. Lock-off or stop button has not been released.

STOPPAGE DURING OPERATION AND FAILURE TO RESTART.

1. Fuses have blown.
2. Overloads have tripped.

GENERAL.

Check the earth (ground) connection from time to time. Users are recommended to display in an appropriate position in the maintenance department a Wadkin Electrical Maintenance Instruction Card, No. 356, which is issued gratis on application.

**DIAGRAM No.
D. 1034**

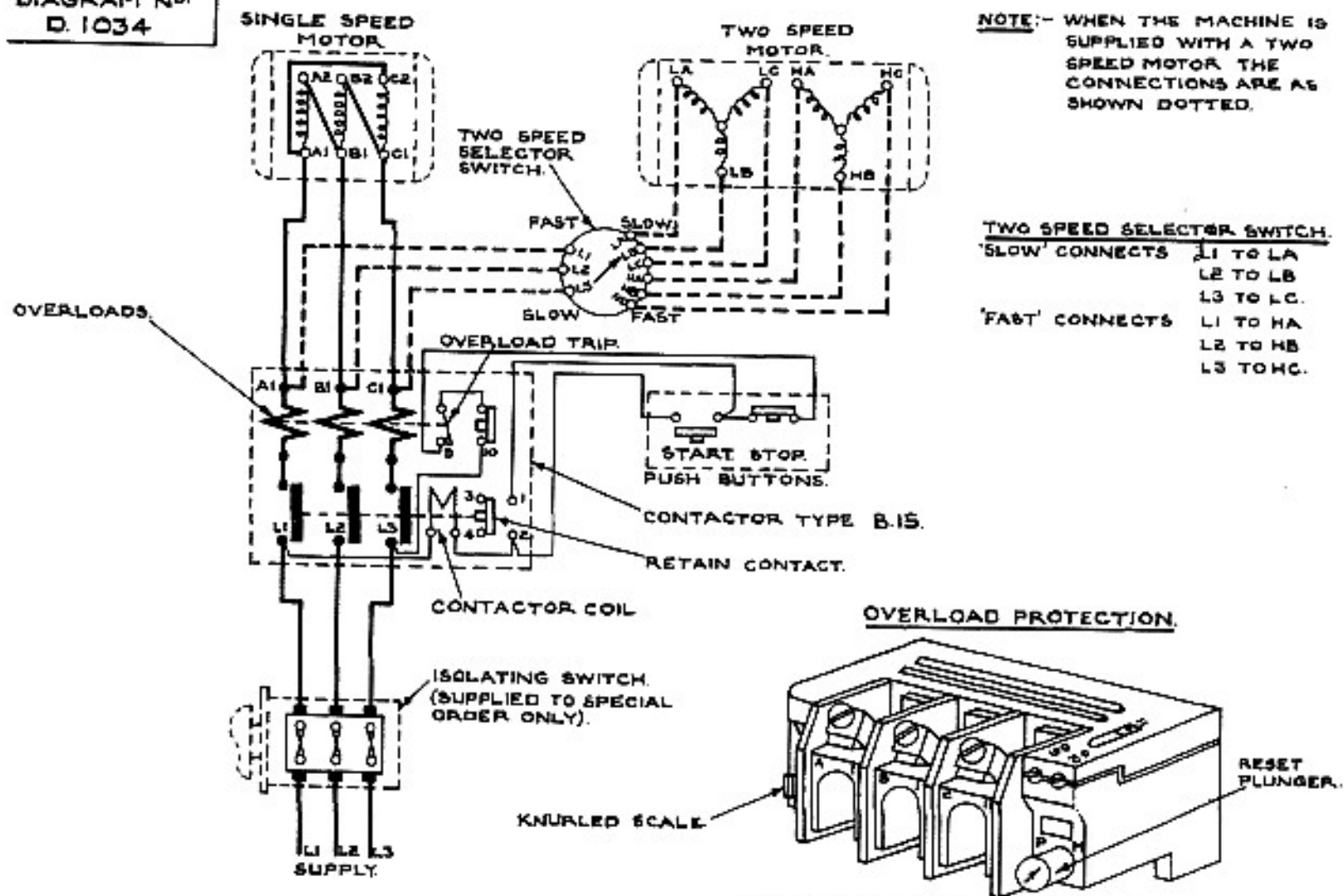

NOTE:- WHEN THE MACHINE IS SUPPLIED WITH A TWO SPEED MOTOR THE CONNECTIONS ARE AS SHOWN DOTTED.

TWO SPEED SELECTOR SWITCH.
 'SLOW' CONNECTS L1 TO LA
 L2 TO LB
 L3 TO LC.
 'FAST' CONNECTS L1 TO HA
 L2 TO HB
 L3 TO HC.

OPERATING INSTRUCTIONS.

TO START MACHINE: CLOSE ISOLATING SWITCH AND PRESS 'START' BUTTON. TO STOP MACHINE: PRESS 'STOP' BUTTON.
 TO LOCK OFF MACHINE: PRESS & TURN 'STOP' BUTTON. THIS MUST BE RELEASED BEFORE A START CAN BE MADE.

DIAGRAM OF CONNECTIONS. (50 CYCLE MACHINES).

DIAGRAM No.
D.1035.

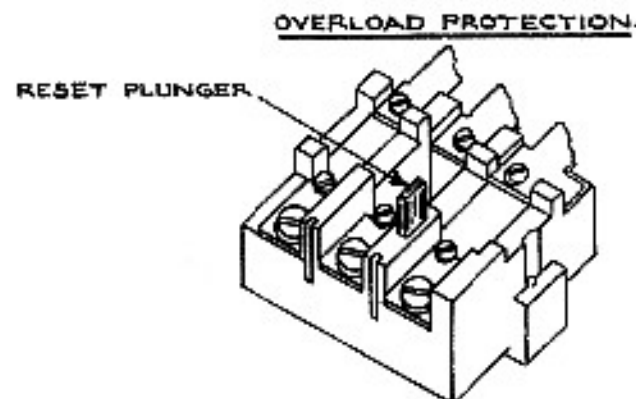
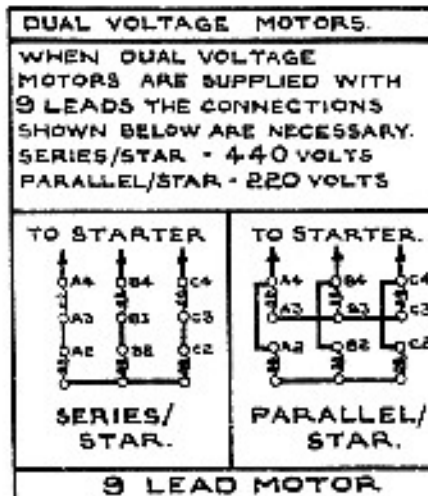
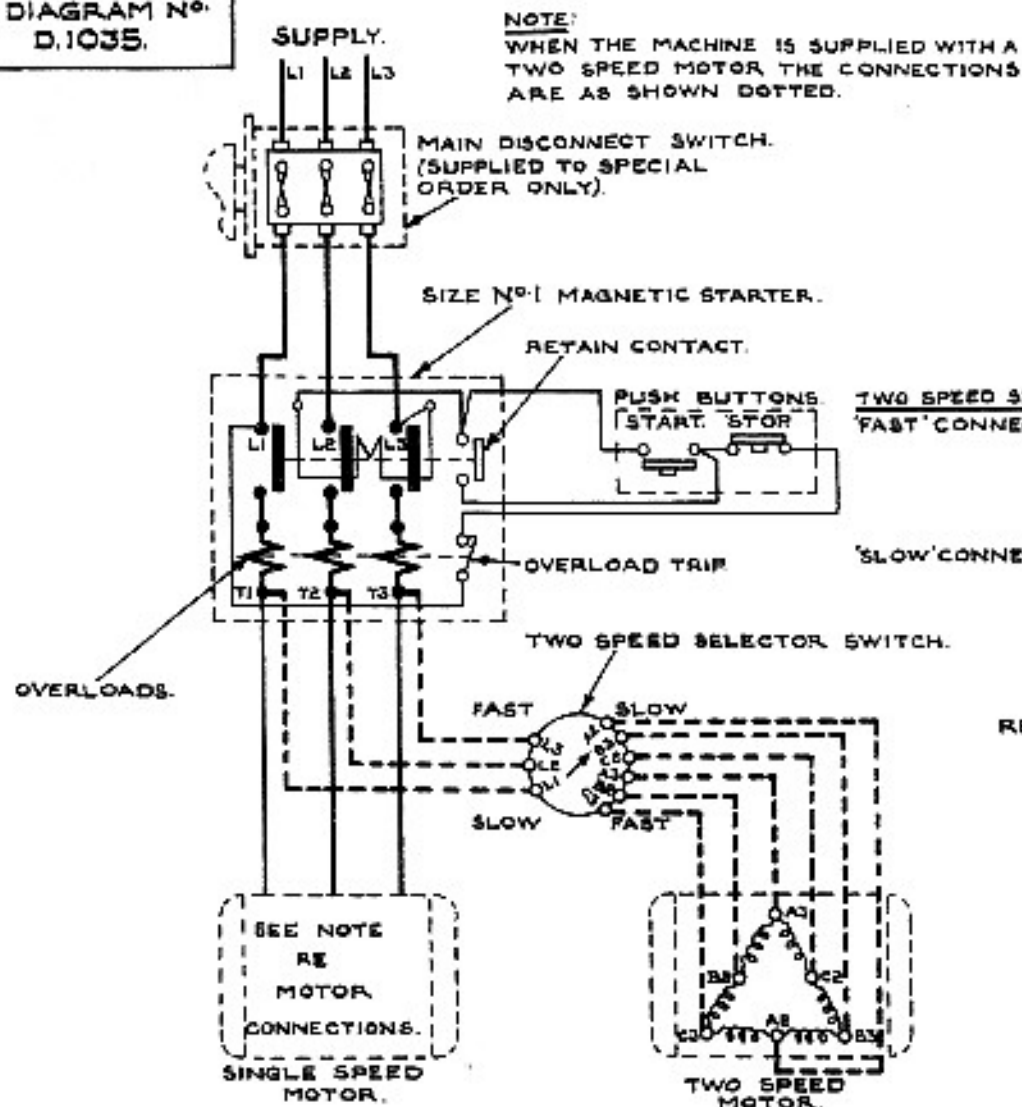

SHOULD THE MACHINE STOP DUE TO OVERLOAD WAIT FOR A SHORT TIME TO ALLOW HEATERS TO COOL. THEN PRESS RESET PLUNGER AND START IN THE USUAL MANNER.

OPERATING INSTRUCTIONS.

TO START MACHINE: CLOSE MAIN DISCONNECT SWITCH AND PRESS 'START' BUTTON. TO STOP MACHINE PRESS 'STOP' BUTTON. TO LOCK OFF MACHINE: PRESS AND TURN 'STOP' BUTTON, THIS MUST BE RELEASED BEFORE A START CAN BE MADE.

DIAGRAM OF CONNECTIONS. (60 CYCLE MACHINES).

Wadkin

T: +44 (0)116 276 9111
F: +44 (0)116 259 8138