

Wadkin

Dimension Saw Type P.K.

PRINCIPAL DIMENSIONS AND CAPACITIES :

Standard size of saw	18"
Maximum depth of cut	4 $\frac{1}{4}$ "
Depth of cut with saw canted to 45°	2 $\frac{3}{8}$ "
Throat opening between table and sliding table	4"
Saw cants up to	45°
Maximum distance between saw and ripping fence on standard table	24"
Will cross cut 4 $\frac{1}{4}$ " deep up to width of } on standard table	30"
Will cross cut 1" deep up to width of }	36"
Length cut off using stops on fences	36"
Ripping fence cants up to	45°
Horse power of motor	4
Speed of motor in r.p.m. on 50 cycles	3,000

Details included with the machine:

- | | |
|-------------------------------|---------------------------------------|
| One pair saw collars and nut. | Double mitre fence with stop. |
| Saw guard and riving knife. | Set of spanners. |
| Ripping fence. | Grease gun. |
| Cutting-off fence with stop | Tin of ball bearing grease lubricant. |

Wadkin OPERATING AND MAINTENANCE INSTRUCTIONS

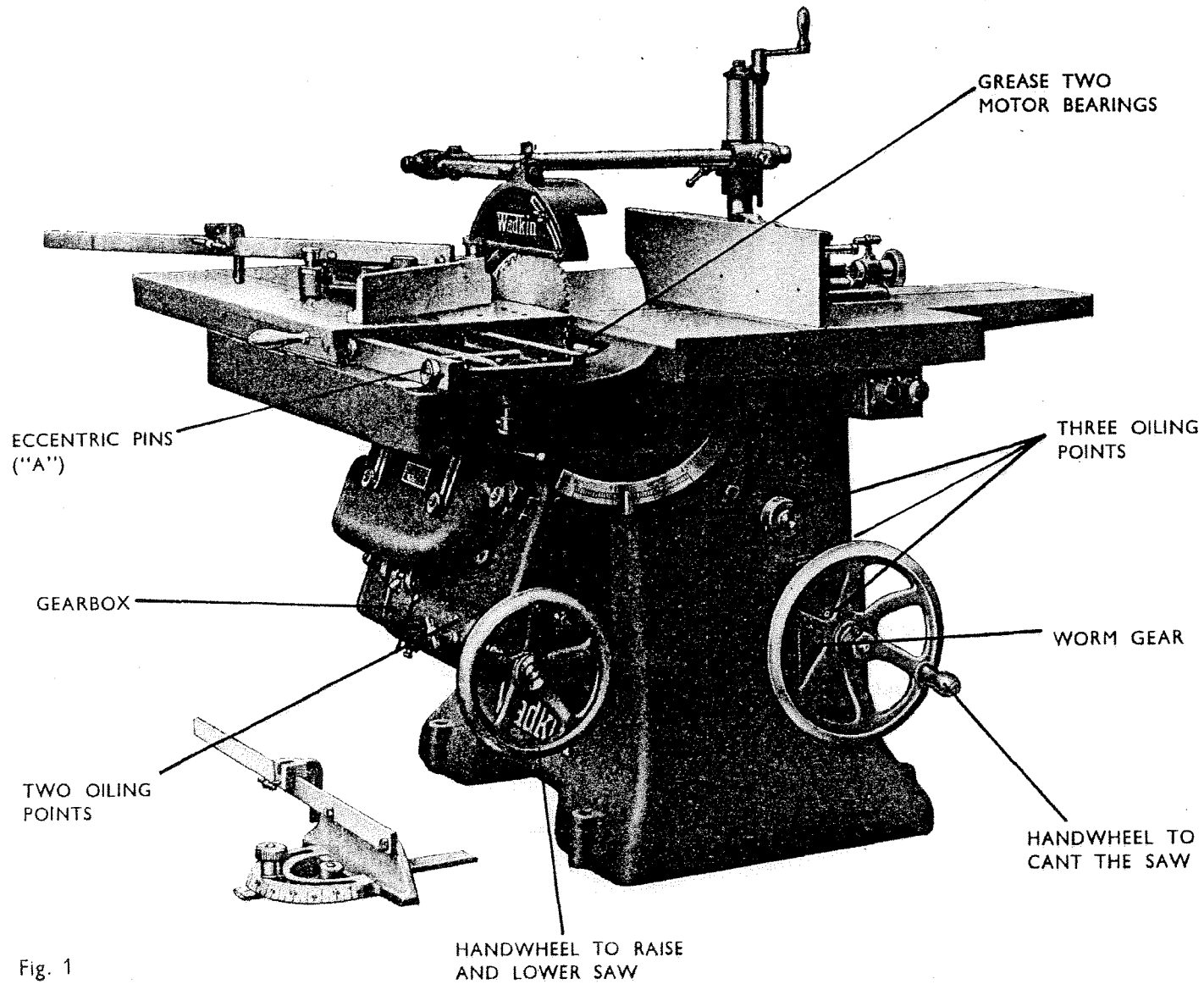

Page 3

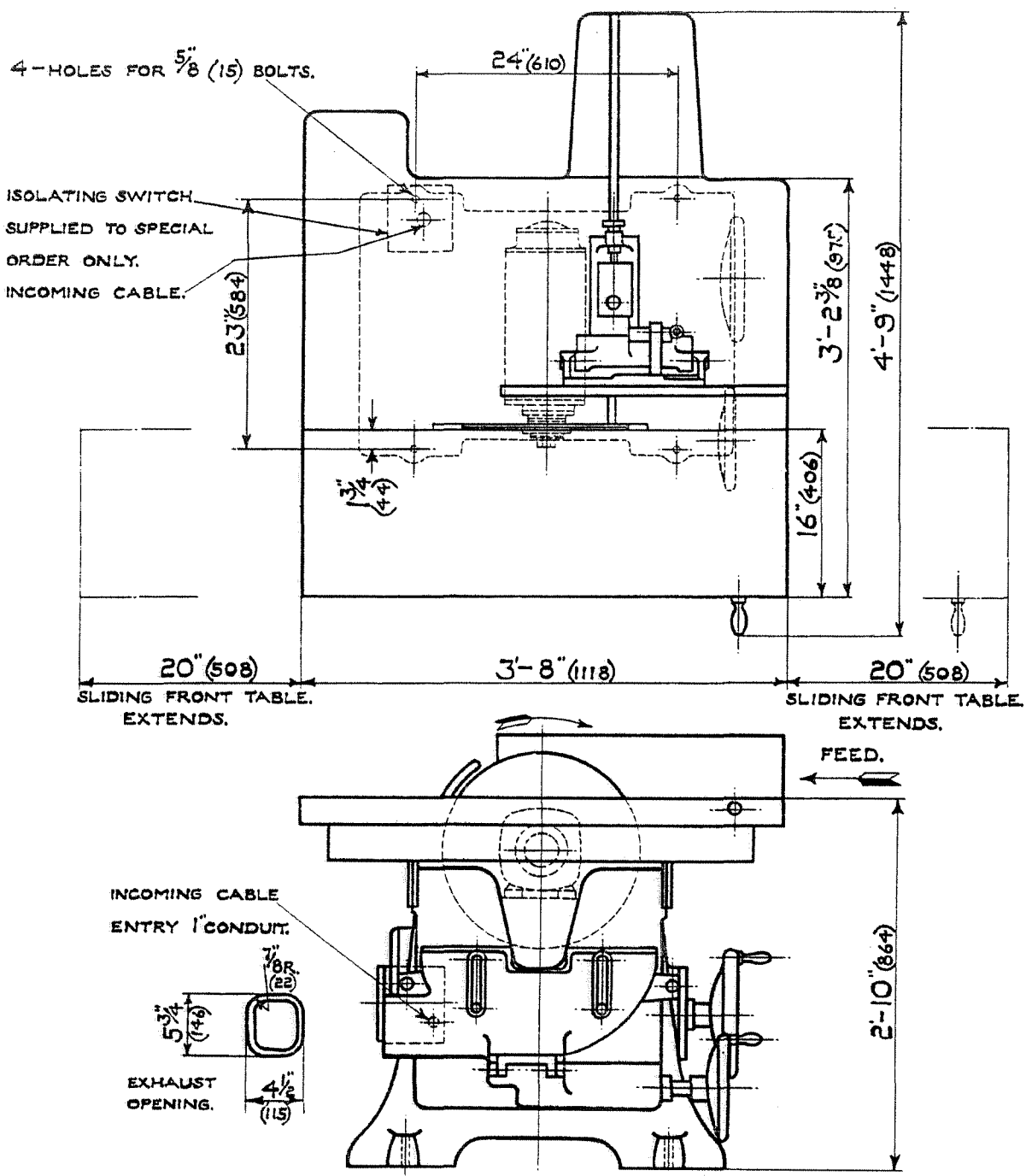

18" CANTING SPINDLE DIMENSION SAW-TYPE P.K.
MACHINE WITH STANDARD TABLE AND CAPACITY

THE MACHINE is despatched from our works with all bright surfaces greased to prevent rusting. This must be removed by applying a cloth damped in paraffin or turpentine.

THE MOTOR. See end of booklet for electrical installation instructions.

LUBRICATION

BALL BEARINGS (TWO) IN MOTOR Give three or four depressions of the grease gun to each bearing every three months.

TABLE ROLLERS AND OTHER OILING POINTS Oil daily.

GEARBOX Give five to six depressions of the grease gun every 6 months.

WORM GEAR Grease every 12 months:

The grease lubricant recommended is Wadkin Grade L.6. Alternative grease,
Shell-Mex & B.P. Ltd. — Shell NERITA GREASE 3
Vacuum Oil Co. — GARGOYLE GREASE BRB 3
Caltex Lubricants — REGAL STARFAK No. 2 GREASE

For oil lubrication, use Wadkin Grade L.4. Alternatively
Shell-Mex & B.P. Ltd. — Shell VITREA OIL 33
Vacuum Oil Co. — GARGOYLE VACTRA OIL (heavy medium)
Caltex Lubricants — CALTEX ALEPH OIL

THOROUGHLY CLEAN DOWN MACHINE WEEKLY.

Wadkin OPERATING AND MAINTENANCE INSTRUCTIONS

TOTALLY
ENCLOSED
FAN COOLED
MOTOR
TYPE ZEF.

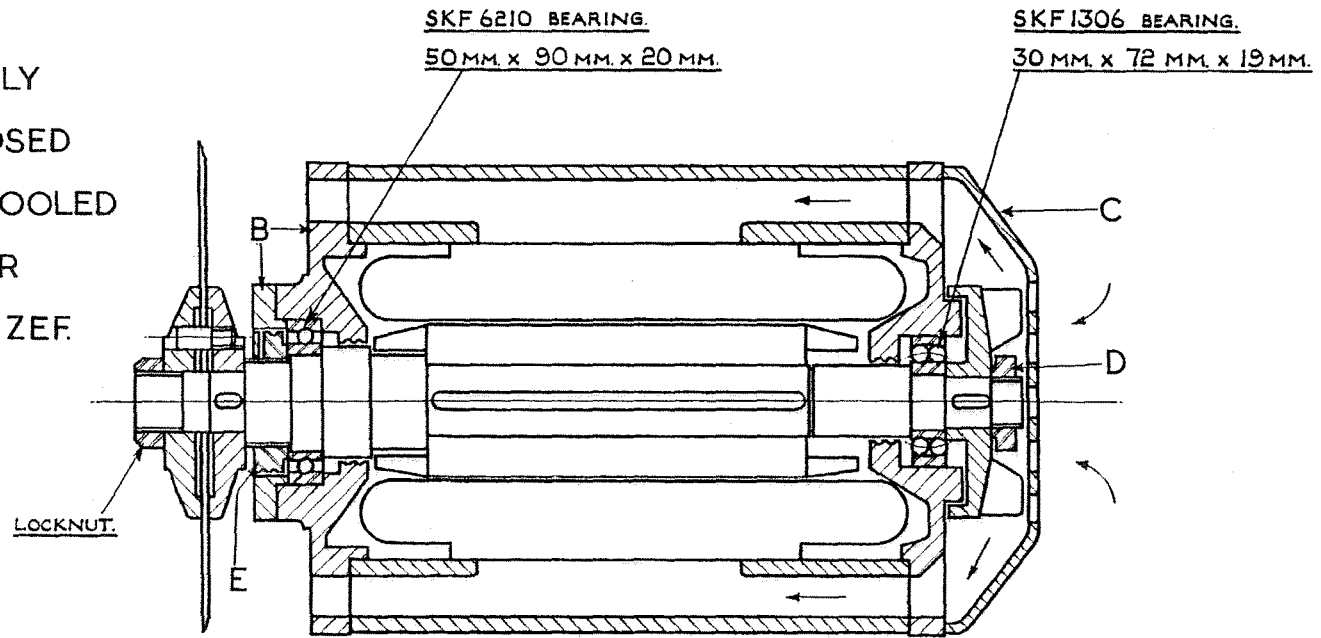

DETAIL OF
SPINDLE AND
PIN
FOR CIRCULAR
SAWS.

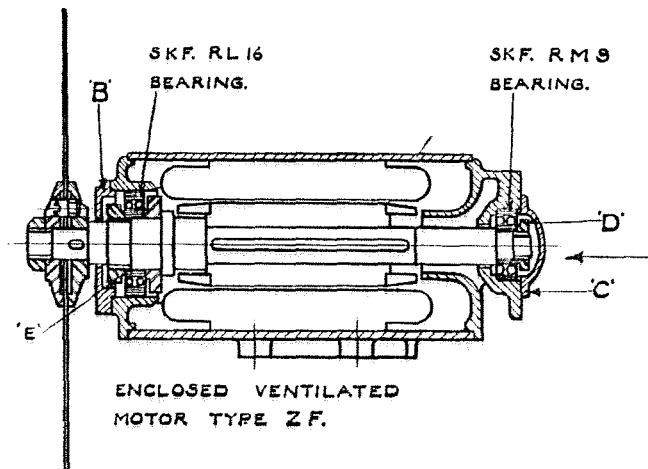
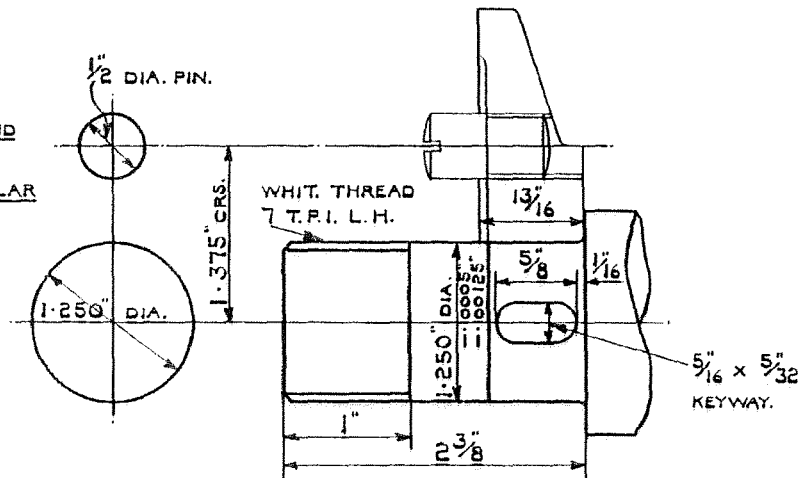

ENCLOSED VENTILATED
MOTOR TYPE ZF.

SPINDLE ASSEMBLY

To remove saw spindle from machine for renewing ball bearings, etc., proceed as follows:

TO REMOVE THE MOTOR

1. Isolate the machine electrically, and remove the push-button box, by first removing the plate for access to the screws inside the box. Disconnect the wiring to the contactor.
2. Clear the table top by removing the complete saw guard and all the fences. Take off saw.
3. Unlock the clamp handles which hold the sliding table in position and unwind them from their studs. Lift the sliding table off complete.
4. Remove the four hexagon-head screws (two inside the frame) which hold the table to the main frame. Lift off the table, keeping it square to prevent the two dowel pins jamming.
5. Wind the motor carriage to its 45° position and remove from underneath the four hexagon-head screws which hold the motor. Wind back to the 90° position, and lift out the motor unit and place on a bench.

TO DISMANTLE MOTOR

6. Remove the saw flanges with a soft metal drift.
7. Take off the end caps B and C.
8. Unscrew the rear bearing locknut D and take off fan impeller and key in the ZEF motor.
9. Knock out the spindle from the tail end of motor using a piece of wood or soft metal (brass, copper, lead).
10. Knock bearing out of rear housing. This is facilitated if the housing is removed.
11. Unscrew the bearing locknut E (which has a left-hand thread) after loosening the small countersunk locking screw. The front bearing can now be removed.

TO REASSEMBLE

Before assembly clean out all old lubricant. To assemble, reverse the above procedure, ensuring that no dirt or grit enters the bearings or housings. Smear the bearings with Wadkin Ball Bearing Grease, Grade L.6. When fitting the ball bearings do not hammer the races into position but give gentle taps with a soft rod all round the periphery. The inner race should be a good push-fit on the spindle and the outer race a good sliding-fit.

THE TABLE

The table is in two sections, the front or left hand portion sliding on ball bearing rollers. Both sections are grooved on the surface to accommodate a cross cutting fence. When this fence is not in use, steel strips fill in the grooves leaving the table top clear for ordinary working. It is essential that both tables are dead level. These are carefully adjusted before leaving our works by eccentric pins at "A," Fig. 1, and must not be touched. The front or sliding portion of the table is used when accuracy is required in producing glue joints, mitres, bevels, etc. In carrying out such work the table and timber, which is held against the fence is passed by the saw. The wood filling in pieces in the table gap, must be renewed when necessary because they prevent the work from breaking out or splching at the edges.

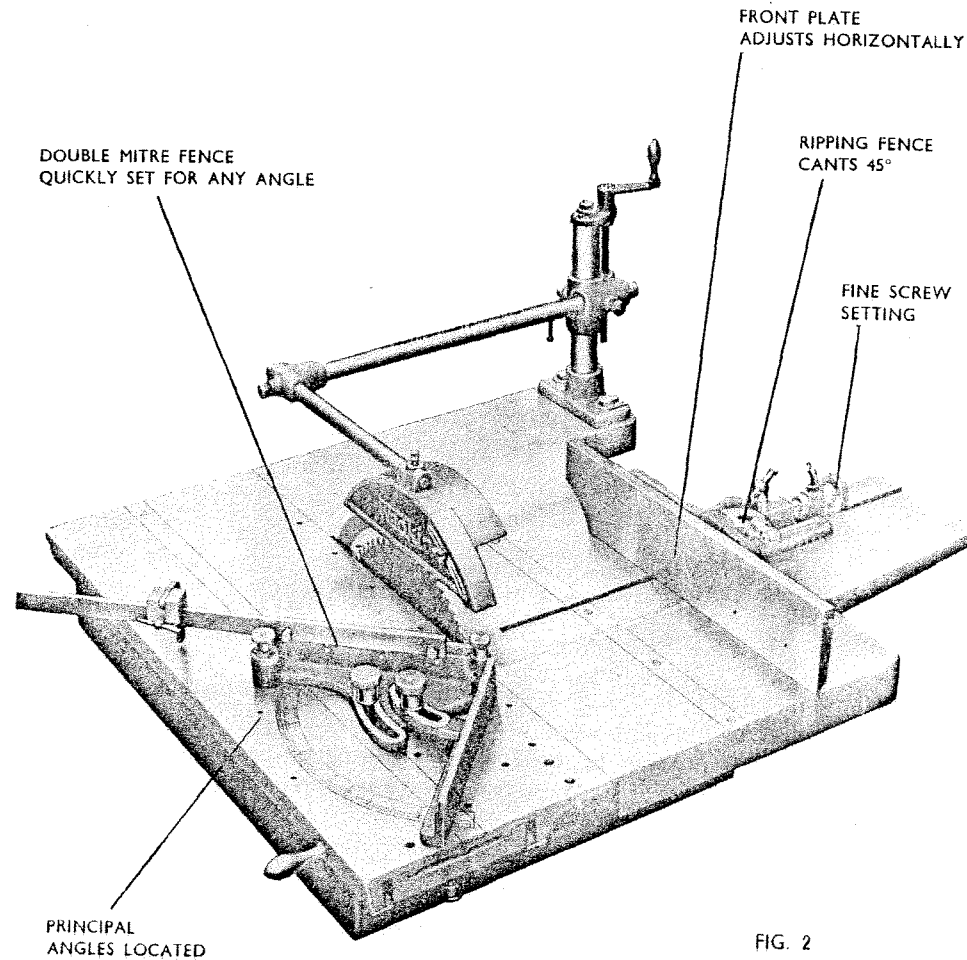

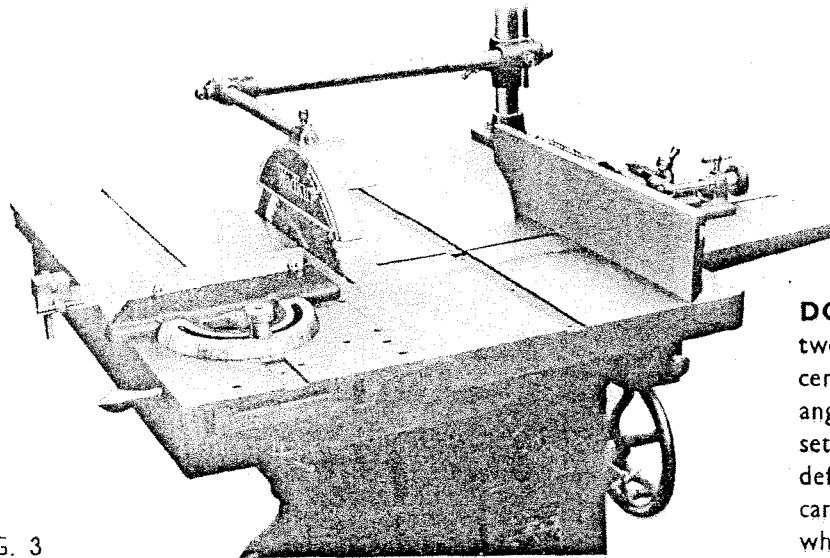

FIG. 3

THE FENCES

CROSS CUTTING FENCE in Fig. 3, is used for both square and angular work and can be used either side of the saw in the table grooves. A bar and stop determines the exact length of the timber cut off.

DOUBLE MITRE FENCE, Fig. 2, is in two parts, both made to pivot from a central pin fixed in sliding table. Degree angles are marked on the table for accurately setting the fences, the principal angles being definitely located by spring plunger. Mitres can be cut giving accurately squared frames when assembled. A bar and stop determines the exact length of the material cut off.

THE RIPPING FENCE, Fig. 2, is for general sawing and will cant up to 45° for bevelling. The front plate is adjustable longitudinally and therefore the fence can be used when grooving or ploughing. The fine screw adjustment gives fine setting to the fence from the saw.

TRENCHING AND GROOVING

Cutter heads can be supplied for cutting any width of groove up to 2" wide and are fixed in the manner shown at Fig. 4. The sliding table is drawn back as indicated to suit the grooving head. A wood filling-in piece is usually inserted to close the gap and to support the work during the grooving operation.

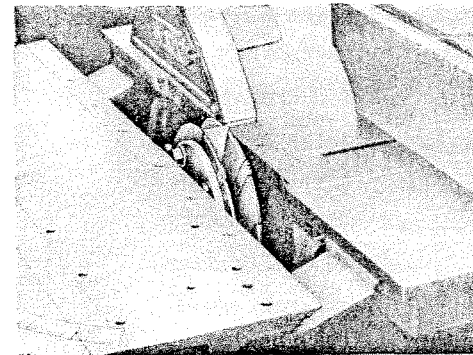

FIG. 4



18" RIPPING SAW FOR GENERAL WORK.
PART No. QS10.



18" HOLLOW GROUND QS12.
18" FLAT CROSS CUT SAW QS11.



14" HOLLOW GROUND SAW QS33
for cutting Bakelite, Tufnol and similar
materials

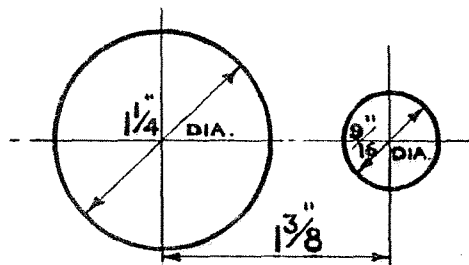

SPINDLE AND PIN HOLES IN SAWS.

**SAWS FOR USE ON
THE P.K. TYPE DIMENSION SAW**

The saws illustrated are specially manufactured and tensioned to run at high speed ; it is therefore recommended they are obtained from us. The teeth are designed to give the best possible finish to the work.

Always keep the teeth sharp with an even set on both sides. Before putting a new saw to use it must be ranged down when running at normal speed and each tooth brought to a sharp cutting edge.

BALL BEARING LIST

One SKF. RL 16 on saw spindle } For ZF type motor
One SKF. RM 9 on saw spindle }

One SKF. 6210 on saw spindle } For ZEF type motor
One SKF. 1306 on saw spindle }

Eight SKF. RMS.5 on sliding table

Three SK. O.8 on canting motor

TRENCHING AND GROOVING HEADS

This type is expandable and made in two sizes 13" diameter. Accurate spacing collars give the desired width of cut rising by $\frac{1}{16}$ " up to the maximum. It is arranged to give a shearing cut and provided with side or spur cutters to produce clean cutting. The head is mounted on a loose sleeve and locked tight by a fine thread nut. One sleeve only is required for the two sizes of head.

J.P. 550 for grooves $\frac{1}{2}$ " to 1" wide and $1\frac{1}{2}$ " deep

J.P. 558 for grooves $1\frac{1}{16}$ " to 2" wide and $1\frac{3}{4}$ " deep

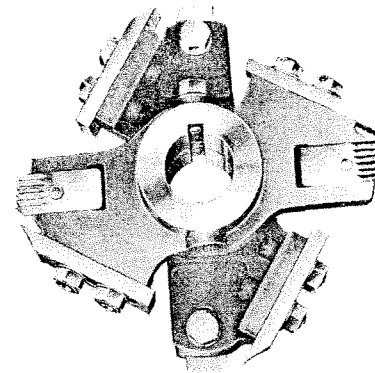

The head illustrated opposite can be used with equal facility but is not capable of such fine adjustment for width of groove as the one shown above. The width of cut is varied by changing the cutters. Side or spur cutters in addition to the grooving cutters effect clean cutting.

Head J.P. 215 is 11" diameter and will groove $\frac{3}{4}$ " to 2" wide 1" deep.

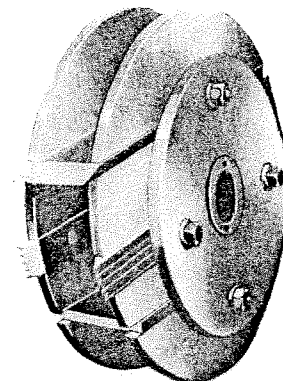

ELECTRICAL INSTALLATION INSTRUCTIONS

The cabling between the motor and the control gear has been carried out by Wadkin Ltd., and it is only necessary to bring the line leads to the machine for it to be put into service. This should be done as follows :

1. Fit triple pole isolating switch near the machine unless it has been supplied to special order by Wadkin Ltd., when it will be fitted and connected to the machine.
2. Connect the line lead to the appropriate terminals. See diagram of connections. The cables should be taken to the machine in conduit and secured to the control gear by locknuts.
3. Connect solidly to earth.
4. Close isolating switch and press start button. If motor does not rotate in the right direction, interchange any two incoming line leads.

FAILURE TO START

1. Electric supply is not available at the machine.
2. Fuses have blown or have not been fitted.
3. Isolating switch has not been closed.
4. Lock-off or stop button has not been released.

STOPPAGE DURING OPERATION AND FAILURE TO RESTART

1. Fuses have blown.
2. Overloads have tripped. They will reset automatically after a short time and the motor can be restarted in the usual manner.

ADJUSTMENTS

For a finer overload setting, set the load indicator to a lower value and vice-versa for a less fine setting.

GENERAL

Check the earth connection from time to time. Users are recommended to display in an appropriate position in the maintenance department a Wadkin Electrical Maintenance Instruction Card, No. 356, which is issued gratis on application.

Wadkin OPERATING AND MAINTENANCE INSTRUCTIONS

DIAGRAM N^o.
D.579/1

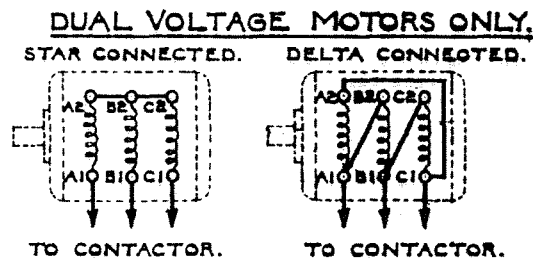
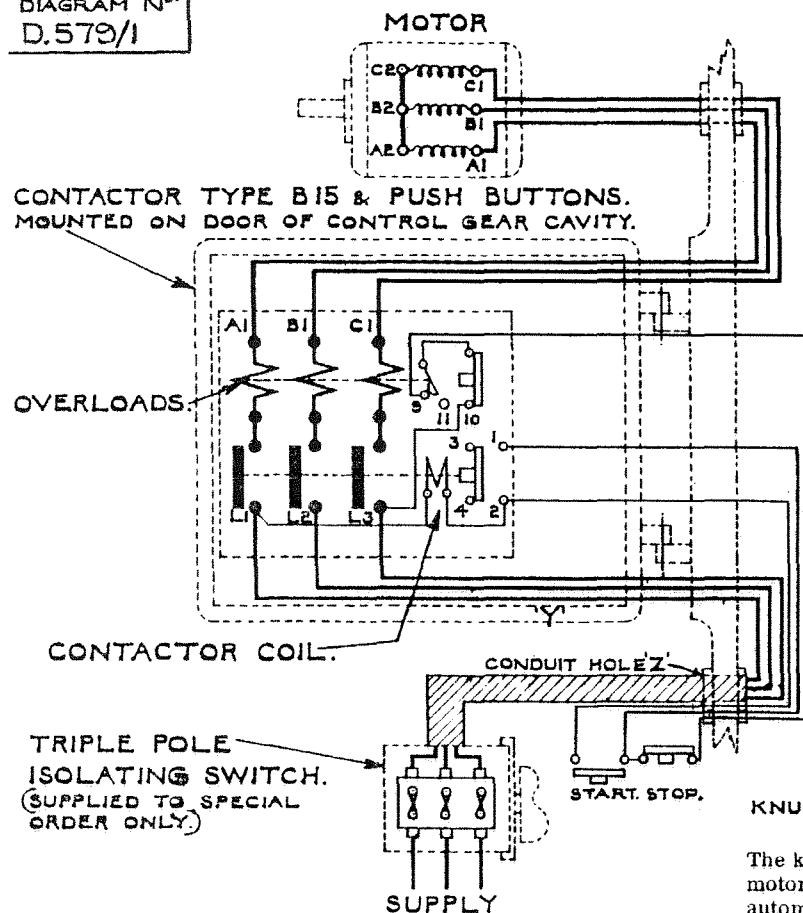

When dual voltage motors are employed the following connections are made:-
200/250 volt circuits, motor delta connected.
340/440 volt circuits, motor star connected. The necessary connections are made either in the control gear cavity or at the motor terminal block.

OVERLOAD PROTECTION.

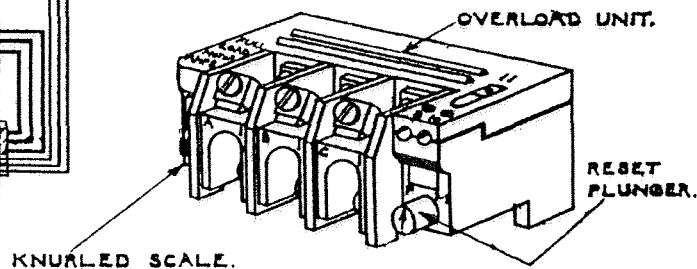

The knurled scale should be set at the full load current of the motor. The arrow on the reset plunger should point to 'M' for automatic reset and 'P' for hand reset.

INSTALLATION INSTRUCTIONS.

Fit triple pole isolating switch near machine, unless supplied by Wadkin Ltd. to special order, so that the electrical gear may readily be isolated for inspection purposes. Bring supply cables to isolating switch and to L1 - L2 - L3 at contactor through conduit which should be screwed into the machine and secured by means of locknuts. A hole is provided in the machine frame at 'Z' for the conduit carrying the cables to the contactor. Leave sufficient slack in the cables at 'Y' to allow the door to open freely. Ensure that the machine is adequately 'earthed' and that the direction of rotation of the motor is correct before putting machine into service. To reverse rotation interchange L1 and L3.

OPERATING INSTRUCTIONS.

To start machine, close isolating switch and press 'start' button. To stop machine press 'stop' button. To lock off machine, press and turn stop button. This must be released before a start can be made.

NOTE:- Cabling shown thus to be carried out by customer unless isolating switch has been fitted by Wadkin Ltd.

Wadkin OPERATING AND MAINTENANCE INSTRUCTIONS

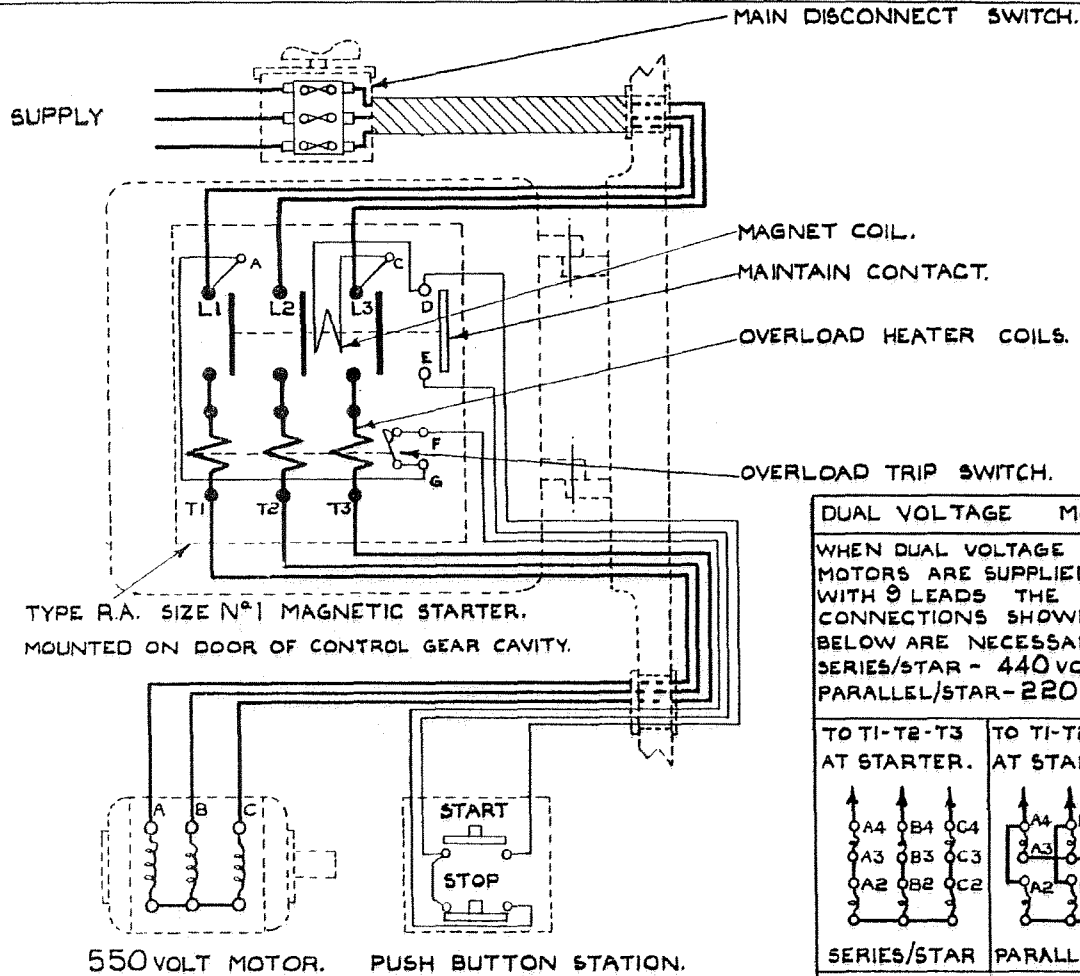

DUAL VOLTAGE MOTOR CONNECTIONS.			
WHEN DUAL VOLTAGE MOTORS ARE SUPPLIED WITH 9 LEADS THE CONNECTIONS SHOWN BELOW ARE NECESSARY. SERIES/STAR - 440 VOLTS. PARALLEL/STAR - 220 VOLTS.		WHEN DUAL VOLTAGE MOTORS ARE SUPPLIED WITH 6 LEADS THE CONNECTIONS SHOWN BELOW ARE NECESSARY. STAR - 340/440 VOLTS. DELTA - 200/250 VOLTS.	
TO T1-T2-T3 AT STARTER.	TO T1-T2-T3 AT STARTER.	TO T1-T2-T3 AT STARTER.	TO T1-T2-T3 AT STARTER.
9 LEAD MOTORS.		6 LEAD MOTORS.	

INSTALLATION INSTRUCTIONS.

FIT MAIN DISCONNECT SWITCH NEAR MACHINE SO THAT THE ELECTRICAL GEAR MAY READILY BE ISOLATED FOR INSPECTION PURPOSES. BRING SUPPLY CABLES TO DISCONNECT SWITCH AND TO L1-L2-L3 AT MAGNETIC STARTER THROUGH CONDUIT WHICH SHOULD BE SCREWED INTO THE MACHINE FRAME AND SECURED BY MEANS OF LOCKNUTS. ENSURE THAT THE DIRECTION OF ROTATION OF THE MOTOR IS CORRECT BEFORE PUTTING THE MACHINE INTO SERVICE. TO REVERSE ROTATION INTERCHANGE L1 AND L3 AT MAGNETIC STARTER.

OPERATING INSTRUCTIONS.

TO START MACHINE: CLOSE MAIN DISCONNECT SWITCH AND PRESS 'START' BUTTON. TO STOP MACHINE: PRESS 'STOP' BUTTON. TO LOCK OFF MACHINE: PRESS AND TURN 'STOP' BUTTON, THIS MUST BE RELEASED BEFORE A START CAN BE MADE.

OVERLOAD.

SHOULD THE MACHINE STOP DUE TO OVERLOAD, THE OVERLOAD TRIP SWITCH SHOULD BE RESET BY DEPRESSING THE PLUNGER ON THE OVERLOAD ASSEMBLY, THEN START IN THE USUAL MANNER.

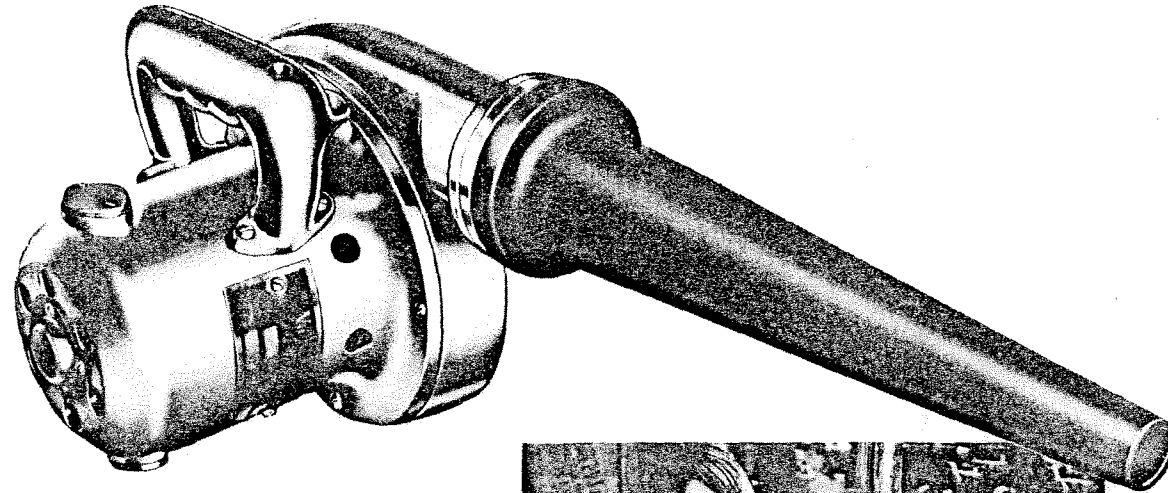

**... blow away harmful dust,
chips and dirt with a
Wadkin Electric Blower**

No motor can run at its maximum efficiency with its ventilating duct or control gear covered with dust and dirt. Sooner or later the resultant overheating will cause serious trouble.

Similarly, accumulations of chips and dust, in the mechanical parts of the machine can interfere with its efficiency. A few minutes a week for blowing down all Woodworking Machinery will be amply repaid in better and easier running, in increased life, and freedom from breakdown.

Blowers can be supplied for single phase A.C. or Direct Current for any voltage up to 250.

Please state voltage when ordering.

