

ULTRACARE

At the Cutting Edge of Industry

OPTI-CASS

OPTICAL SETTING SYSTEM

INSTRUCTION MANUAL No 4006/2

OPTICAL SETTING SYSTEM

MODEL: OPTI-CASS

INSTRUCTION MANUAL

ULTRACARE Ltd.

Tel: spares +44 (0) 116 276 9111

Fax: +44 (0) 116 259 8138

E-mail: info@wadkinultracare.com

Web: www.wadkinultracare.com

OPTI-C.A.S.S.

INSTRUCTION MANUAL

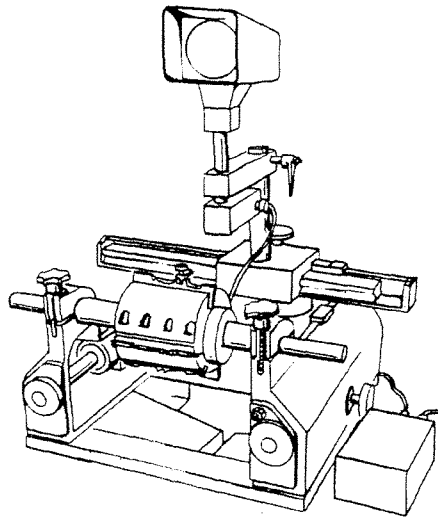

The WADKIN TOOLING Setting System
(OPTI-CASS) is designed to take the guesswork out of setting
up tooling on moulding machines.

The normal methods of positioning tooling on the machine are
to use either a rule and straight edge or a master pattern.
Both of these methods can be inaccurate and often lead to it
being necessary to re-adjust head positions to correct any
error. Unfortunately, this leads to lost production time on
the machine and often scrapped component stock.

By using OPTI-CASS these errors are eliminated as the system
provides preset co-ordinates for each head position. These co-
ordinates are transferred onto a setting card for each tool.
The machine setter now taking each piece of tooling may read
the setting information and adjust spindle position to suit.

CONTENTS

<u>Section</u>	<u>Description</u>	<u>Page No.</u>
1.	CONCEPT	3
2.	INSTALLATION	5
	2.1. Where Things Are	5
	2.2. Fitting Attachments	6
	2.3. Setting Up	6
	2.4. Datuming the Moulding Machine	9
	2.5. Measuring Cutterheads	9
6.	SPARE PARTS / OPTIONAL EXTRAS	

SECTION 1 - CONCEPT

OPTI-CASS works by positioning a known datum point on each tool relative to a corresponding datum point on the timber moulding.

IN the sketch below is shown a sample moulding section. The section is viewed from the out-feed end of the machine. There are also two axes shown; 'VERTICAL' representing height from bed level, 'HORIZONTAL' representing distance from fence line.

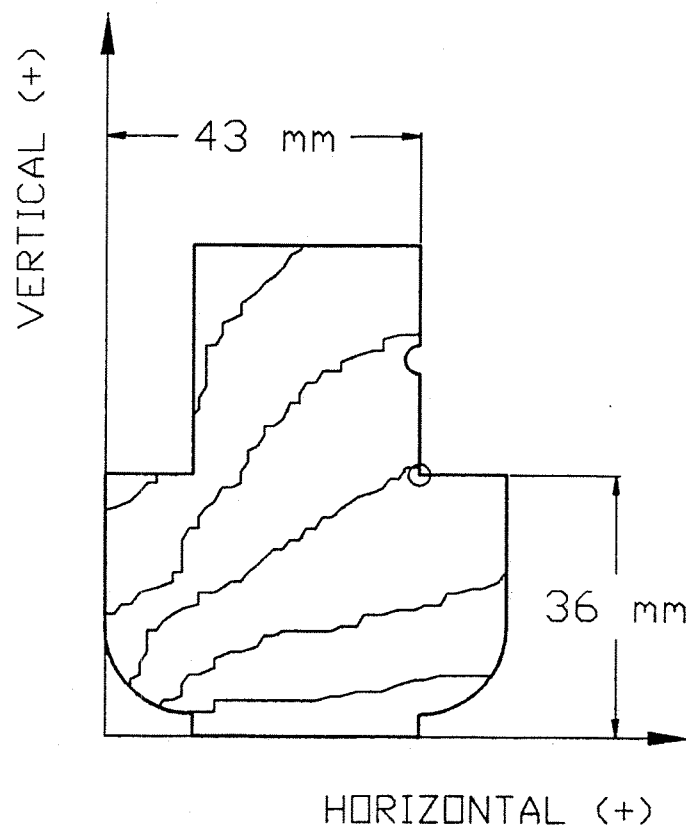

Considering the near side spindle, a datum point has been chosen on part of the moulding which shall be machined by that spindle. The datum point used has been chosen for convenience and is 43 mm from the Fence Line (HORIZONTAL = 43) and 36 mm from Bed Level (VERTICAL = 36).

Now if the tool which will produce the near side head moulding is measured to the same datum point, as shown below, then the position of the spindle can be worked out.

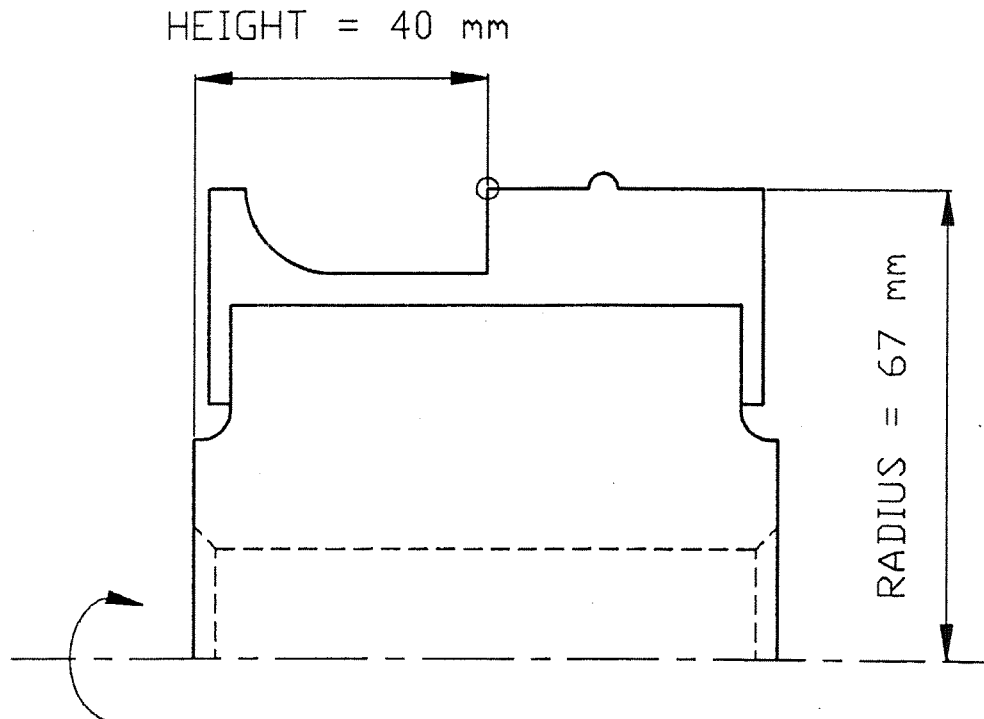

By looking at both the dimensions to the mould datum point, and the tool datum point, the position of the head should be as follows:

$$\begin{aligned} \text{Distance from Fence Line} &= 43 + 67 \\ &= 110 \text{ mm} \end{aligned}$$

$$\begin{aligned} \text{Distance from Bed Level} &= 40 - 36 \\ &= 4 \text{ mm} \end{aligned}$$

So, by positioning the cutterhead 110 mm from Fence Line, and 4 mm below Bed Level, the timber moulding will be machined with the profile in the correct position, and to the correct size.

The above calculations are performed automatically by OPTI-CASS.

SECTION 2 - INSTALLATION

2.1. Where Things Are

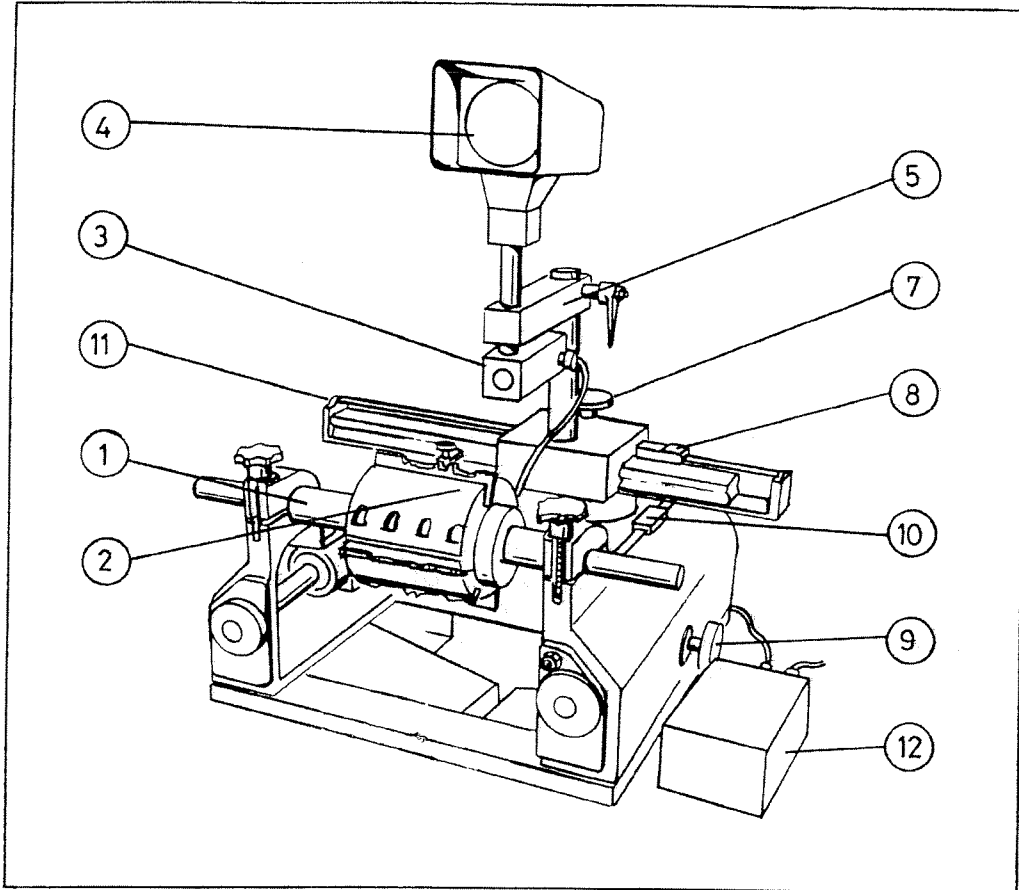

- | | |
|------------------|---------------------------------|
| 1. Arbor | 7. Length measurement handwheel |
| 2. Cutterhead | 8. Length measuring scale |
| 3. Illuminator | 9. Radius measurement handwheel |
| 4. Optical Scope | 10. Radius measurement scale |
| 5. Clamp Bracket | 11. Bridge |
| | 12. Power unit |

2.2. - Fitting Attachments

The OPTI-CASS, due to packing considerations, is supplied as three units. These comprise:

1. The measuring stand.
2. The optics system.
3. The power unit.

It shall be necessary to re-assemble these units before they can be used.

1. The optics assembly.

Take the optics scope and insert in the clamp bracket of the measuring stand. Lock the stem of the optics scope half-way along its length by lightly tightening the screws of the clamp bracket. Then take the optical illuminator and insert over the end of the optics stem and lightly clamp into position.

2. The power unit.

The only electrical connection to be made is from the power unit to the illuminator of the optics assembly. This has a two pin DIN socket which connects into the rear of the power unit. The power unit may then be connected to the electrical supply and switched on using the illuminated switch on the front of the unit.

2.3. Setting Up

Before the equipment may be used, it shall be necessary to adjust the optical scope to bring it into focus and align it correctly. To do this, firstly switch the illuminator on.

Once switched on, load a cutterhead arbor onto the measuring stand. Wind the bridge of the measuring stand forwards until an image of the arbor can be seen in the optical scope.

Un-clamp the stem of the optical scope and carefully move it up or down to obtain a sharp image of the outer edge of the arbor. When in focus rotate the scope in order to align the horizontal cross-hairs with the arbor. When aligned re-clamp the stem.

If only a dull image can be obtained, check that the protective plastic sheet has been removed from the reflective, stainless steel sheet on the base of the stand, and that the sheet is clean and brightly polished.

If the image still remains relatively dull, it shall then be necessary to check the centring of the bulb in the illuminator.

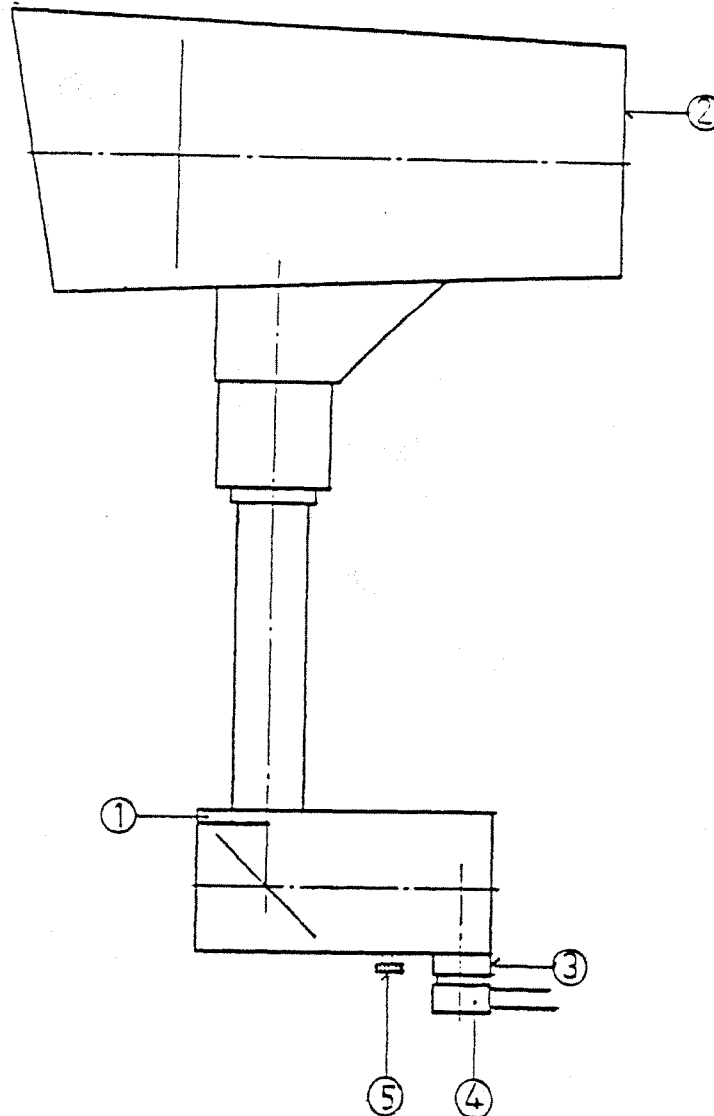

1. Fixing screw for illuminator
2. Optical scope
3. Fixing screw for bulb
4. Bulb socket
5. Condenser screw

To renew and centre the bulb firstly ensure that the illuminator is switched off. Loosen screw (3) and pull the bulb socket (4) out. Set a new bulb in, and push the socket in again (NOTE: The bulb is of the halogen variety and should not be touched with bare fingers).

Switch the illuminator on.

Loosen connector screw (5) and move the condenser away from the light source. Push socket (4) up and down until the image of the bulb filament (bright point) is in the centre of the optics screen. Tighten screw (3).

Push the condenser screw towards the bulb to a point of greatest brightness on the screen. When set, tighten the condenser screw.

2.4. Datuming the Moulding Machine

For OPTI-CASS to function correctly, it is necessary to datum the spindles onto which the tooling is to be set. To do this, the shoulders of the spindles on the horizontal heads must be aligned to the fixed fence of the machine. The shoulders of the spindles on vertical heads must be aligned to the fixed bed of the machine. The grub-screw locking the mechanical counter is released and the knurled bush turned until 0000.0 is displayed on the dial. The grub-screw is then locked again, thus fixing the datum on one axis.

To position the spindles on the second axis, the centre-line of the vertical spindles must be set at zero on fence line and the centre-line of horizontal spindles set at zero on bed level.

2.5. Measuring Cutterheads

1. Wind the bridge plate forward, and 'zero' the radius measuring scale at the front stop screw.
2. Using an arbor, load the cutterhead to be measured onto the stand.
3. Identify which end of the cutterhead shall make contact with the spindle shoulder of the machine it will be used on.
4. Align the cross-hairs of the optical projector with the identified end of the cutterhead by sliding the length measuring scale along. 'Zero' the scale at this position.
5. Move the cross-hairs of the optical projector both lengthways and radially relative to the cutterhead, to align the 'cross' with the datum feature.
6. At this position the two scales will display the
 - a. length measurement from the spindle shoulder end of the cutterhead to the datum feature, and
 - b. the cutting radius to the datum feature.

These two readings are used to calculate spindle position.

OPTI CASS

SECTION 6

Spare Parts

Part No.

Scale Unit (Radius)	T30 49 104
Scale Unit (Length)	T30 49 120
Scale Battery	T30 05 902
Illuminator Bulb	K12 03 418

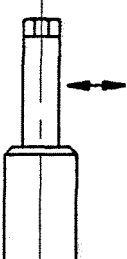
OPTI-CASS SETTING SHEET								
COMPONENT NAME								
2	3	4	5	6	7	8	9	
								

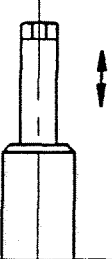
OPTI-CASS SETTING SHEET								
COMPONENT NAME								
2	3	4	5	6	7	8	9	
								

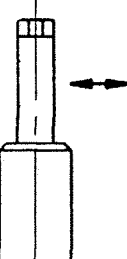

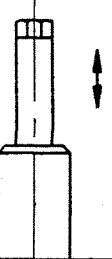
WADKIN TOOLING OPTI-CASS

HEAD REF NO.

COMPONENT NAME

VERTICAL (+)

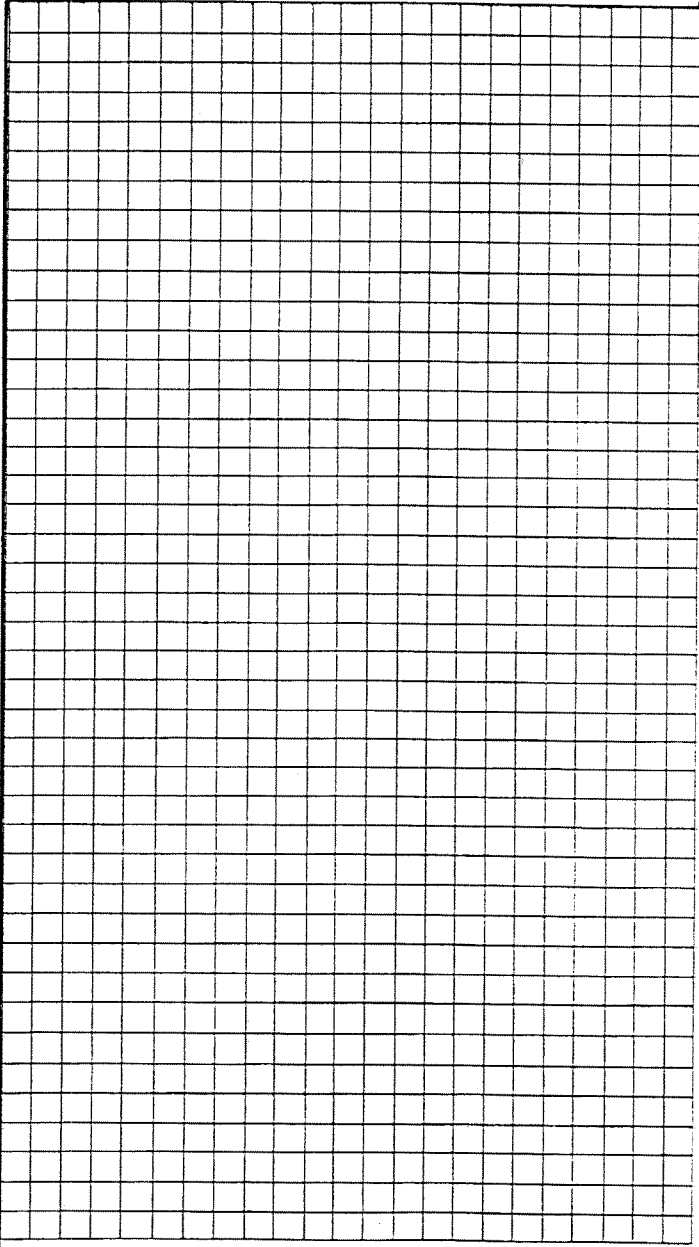







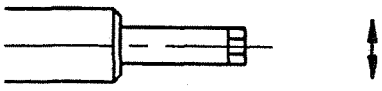

HORIZONTAL (+)

INFORMATION

DRAWN

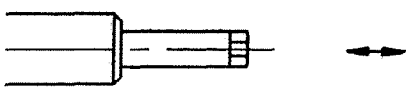
DATE

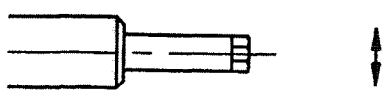
OPTI-CASS SETTING SHEET				
	COMPONENT NAME	HEAD No.	HEAD TYPE	
			T	B N F
				

OPTI-CASS SETTING SHEET				
	COMPONENT NAME	HEAD No.	HEAD TYPE	
			T	B N F
				

OPTI-CASS SETTING SHEET				
	COMPONENT NAME	HEAD No.	HEAD TYPE	
			T	B N F
