

BGB

2500 & 3000 Belt Sander

WHEN ORDERING SPARES OR REQUESTING SERVICE
PLEASE QUOTE FULL SERIAL NUMBER AND INDICATE MODEL TYPE
PLEASE INSERT SERIAL NUMBER OF YOUR MACHINE HERE

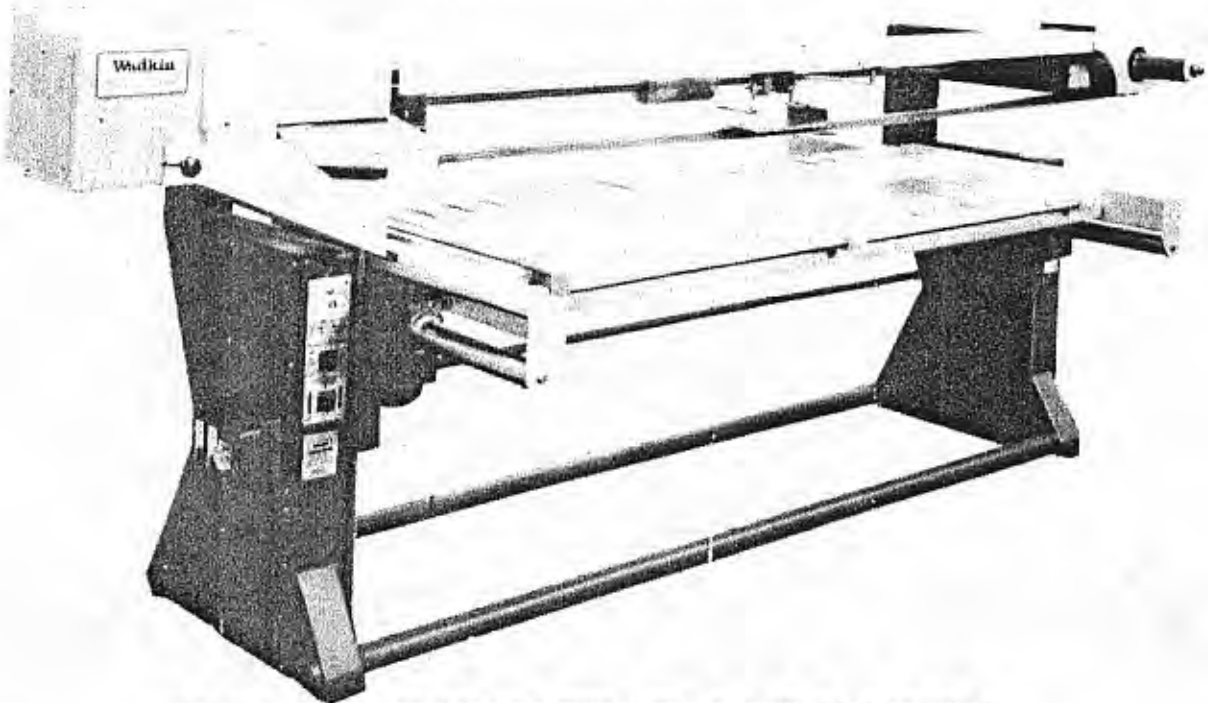

MODIFICATIONS ARE MADE TO THESE BOOKS FROM TIME TO TIME
AS IT IS OUR CONSTANT POLICY TO IMPROVE THE DESIGN OF
BURSGREEN MACHINES. IT IS THEREFORE IMPORTANT THAT THE
BOOK SUPPLIED WITH THE MACHINE BE USED AS AN INSTRUCTION
MANUAL.

HEALTH & SAFETY

SAFETY OF WOODWORKING MACHINES

Woodworking machines can be dangerous if improperly used. The wide range of work of which they are capable, requires adequate safeguarding arrangements against possible hazards.

Many injuries to machinists are caused by carelessness or failure to use the guards provided or to adjust them correctly.

WADKIN LTD., supply machinery designed for maximum safety which they believe, as a result of thorough testing, minimizes the risks inevitable in their use. It is the user's responsibility to see that the following rules are complied with to ensure safety at work:

1. The operation of the machine should conform to the requirements of the Woodworking Machines Regulations 1974. All guards should be used and adjusted correctly.
2. Safe methods of working only should be adopted as given in the Health and Safety Work Booklet No.41, "Safety in the Use of Woodworking Machines", (obtainable from Her Majesty's Stationery Office) and as advised by Wadkin Ltd.
3. Only personnel trained in the safe use of a machine should operate it.
4. Before making adjustments or clearing chips, etc., the machine should be stopped and all movement should have ceased.
5. All tools and cutters must be securely fixed and the speed selected must be appropriate for the tooling.

SAFETY IS OUR WATCHWORD BUT THE USER MUST COMPLY WITH THE ABOVE RULES IN HIS OWN INTEREST. WE WOULD BE PLEASED TO ADVISE ON THE SAFE USE OF OUR PRODUCTS.

oOo

Specification

	BGB 2500	BGB 3000
Effective sanding length (Between frames)	2500mm	3000mm
Effective sanding width (Between frames)	850mm	850mm
Maximum height under sanding belt	650mm	650mm
Rise and fall table motor	.375kW	.375kW
Sanding belt length (+ 50mm)	6900mm	7900mm
Sanding belt width	150mm	150mm
Sanding belt motor	2.2-3kW	2.2-3kW
Sanding belt speed, 2 speed	15-30m/sec	15-30m/sec
Sanding belt pulley diameters	215mm	215mm
Throat depth (Double swan neck)	600mm	600mm
Dust extraction outlet. Diameter	150mm	150mm
Net weight	610kg	635kg
Shipping dimensions	2.47m ³	2.95m ³

Specification

for DE-LUX M/C

As above except :-

Sanding belt length (+ 50mm)	7025	8025
Sanding belt pulley diameters	250	250

LIFTING

THE MACHINE IS NORMALLY SUPPLIED COVERED IN PLASTIC SHEET WITH SUNDRY ITEMS PACKED IN BOXES AND STRAPPED TO THE MACHINE FRAME. BEFORE LIFTING TO WORK POSITION REMOVE SHEETING AND ALL BOXES ALONG WITH ANY LOOSE ITEMS.

THE MACHINE AS RECEIVED IN THIS FORM WILL WEIGH APPROXIMATELY 1100 kg AND SHOULD THEREFORE BE RAISED WITH STRONG ROPES OR SLINGS WHICH ARE KNOWN TO BE IN SOUND CONDITION. THE SLINGS SHOULD BE PLACED TO GIVE A WIDE SPREAD AND SHOULD BE PROTECTED BY PADDING AT THEIR POINT OF CONTACT WITH THE MACHINE. (ie)

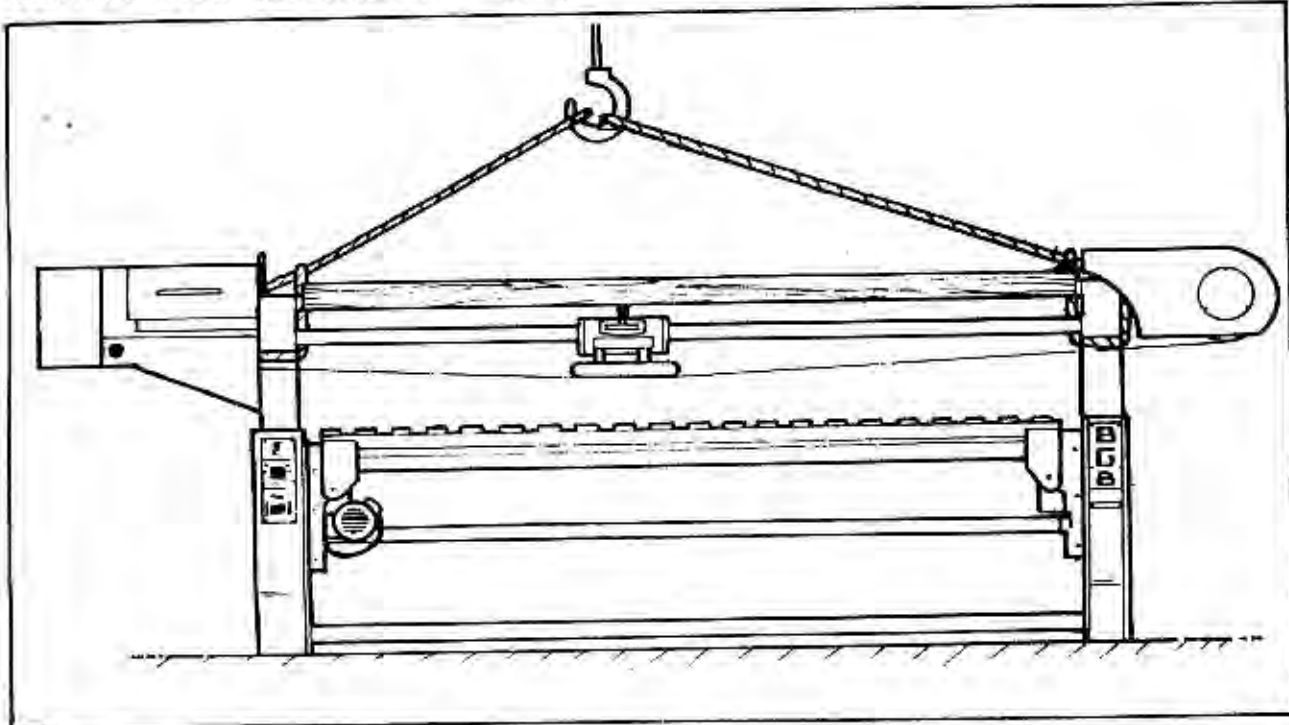

WHEN CRATED FOR EXPORT THE UNIT WILL WEIGH SOME 1200 kg, THE EXACT WEIGHTS, BOTH NETT AND GROSS BEING INDICATED ON THE CRATE. TO LIFT USE EVENLY SPACED SLINGS OR ROPES WHICH ARE KNOWN TO BE IN SOUND CONDITION. (ie)

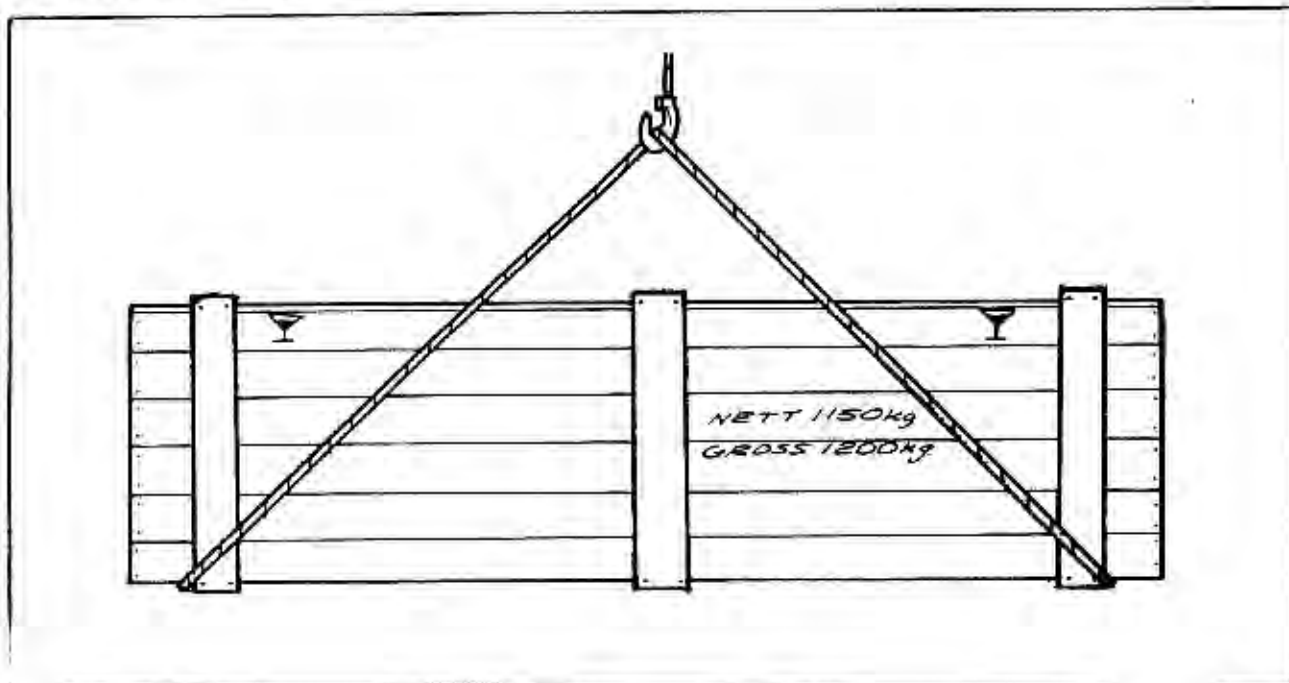

LIFTING NOTES

- 1) WHEN LIFTING WITH ROPE TYPE SLINGS PROTECT AROUND CORNERS OR SHARP EDGES WITH OLD SACKING.
- 2) WHEN USING POWER HOISTS LIFT SLOWLY FROM GROUND LEVEL TO ASCERTAIN STABILITY OF LIFT. A LOAD SHOULD BE RAISED IN THE AIR TO BE SUSPENDED AS LEVEL AS POSSIBLE. IF ON LIFTING THE LOAD SHOWS SIGNS OF TILTING LOWER OFF AND READJUST SLINGS.
- 3) NEVER RAISE A LOAD WITH LOOSE ITEMS UPON IT.
- 4) WHEN MOVING MACHINE OR CRATE TO FOUNDATION POINT VIA OVERHEAD BLOCK OR HOIST, BEFORE MOVING OFF LOWER LOAD DOWN TO WITHIN A COUPLE OF INCHES OFF GROUND LEVEL.
- 5) WHERE LIFTING HOOKS EYE BOLTS OR SPECIAL GRABS ARE PROVIDED ENSURE SUCH FITMENTS ARE SECURED TO THE LOAD BEFORE LIFTING.
- 6) BEFORE USING ANY ROPE, BELT SLING OR CHAINS ENSURE IT IS IN SOUND CONDITION. CUT OR FRAYED ROPES, BELTS OR CHAINS WITH SPRAINED OR SUSPECT LINKS SHOULD NEVER BE USED.
- 7) WHEN OFF-LOADING MACHINE OR CRATE, STAND WELL CLEAR.
- 8) KEEP LOAD STATIONARY WHEN SUSPENDED, DO NOT ALLOW LOAD TO SWING.
- 9) BEFORE LIFTING CHECK MACHINE OR CRATE FOR ANY SPECIAL LIFTING INSTRUCTIONS.
- 10) IF A CRATE IS DAMAGED TO THE POINT WHERE IT IS INSECURE, UNPACK AND LIFT MACHINE ONLY.

Installation:-

Remove protective anti-rust coating from bright parts by applying a cloth soaked in paraffin or other solvent.

Wiring:-

The motor and control gear have been wired in before despatch, therefore all that is required to be done is to connect the mains supply to the starter, or isolator where fitted.

POINTS TO NOTE WHEN CONNECTING TO POWER SUPPLY:-

- 1 - Check voltage, phase and frequency.
- 2 - It is important that the correct cable is used to deliver the correct voltage to the starter. **RUNNING ON LOW VOLTAGE WILL DAMAGE MOTOR.**
- 3 - Check main line fuses are of correct capacity.
- 4 - Connect line leads to correct terminals (SEE WIRING DIAGRAM).
- 5 - Check all connections are sound.
- 6 - Check spindle rotates in correct direction. If not reverse any two of the line lead connections.

FAILURE TO START:-

- 1 - Fuses have blown or have not been fitted.
- 2 - Isolator switch has not been closed.
- 3 - Lock off or stop button (when fitted) has not been released.
- 4 - Supply not available at machine.

STOPPAGE DURING OPERATION & FAILURE TO RESTART:-

- 1 - Overloads have tripped. If hand re-set, set by pressing button. If automatic they will re-set after a short period.
- 2 - Fuses have blown.

FOUNDATION:-

Due to the large area covered by the base it is not required to fix the machine to the floor and as such foundation fixtures are not provided. However, for these customers who require a permanent foundation the following suggestion is made in the form of four brackets. (eg)

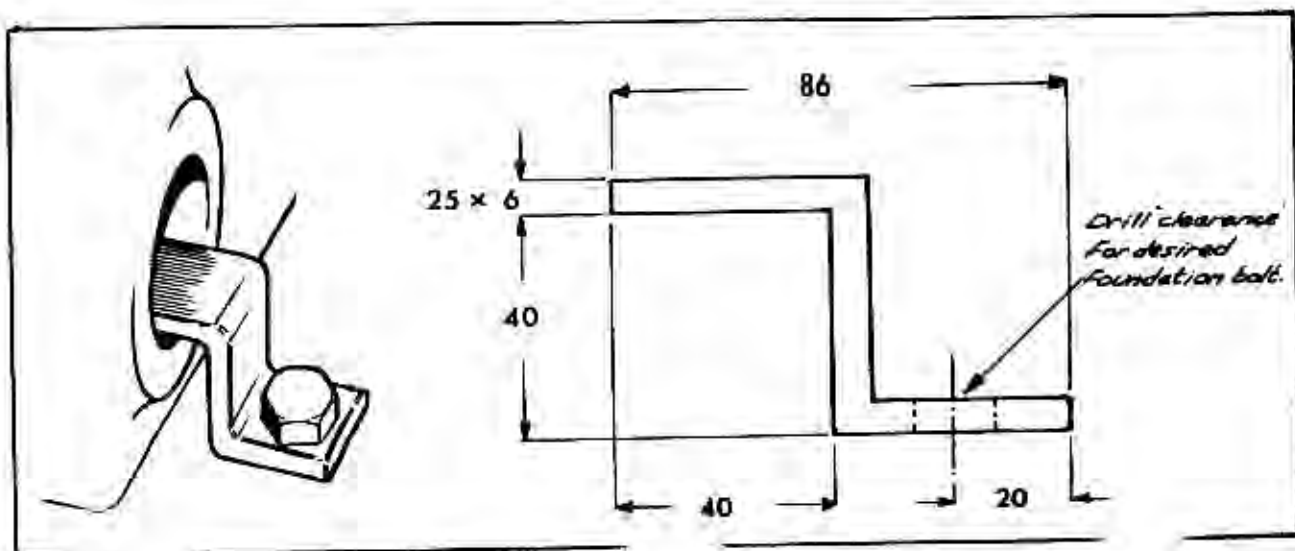

THREE PHASE CIRCUIT.

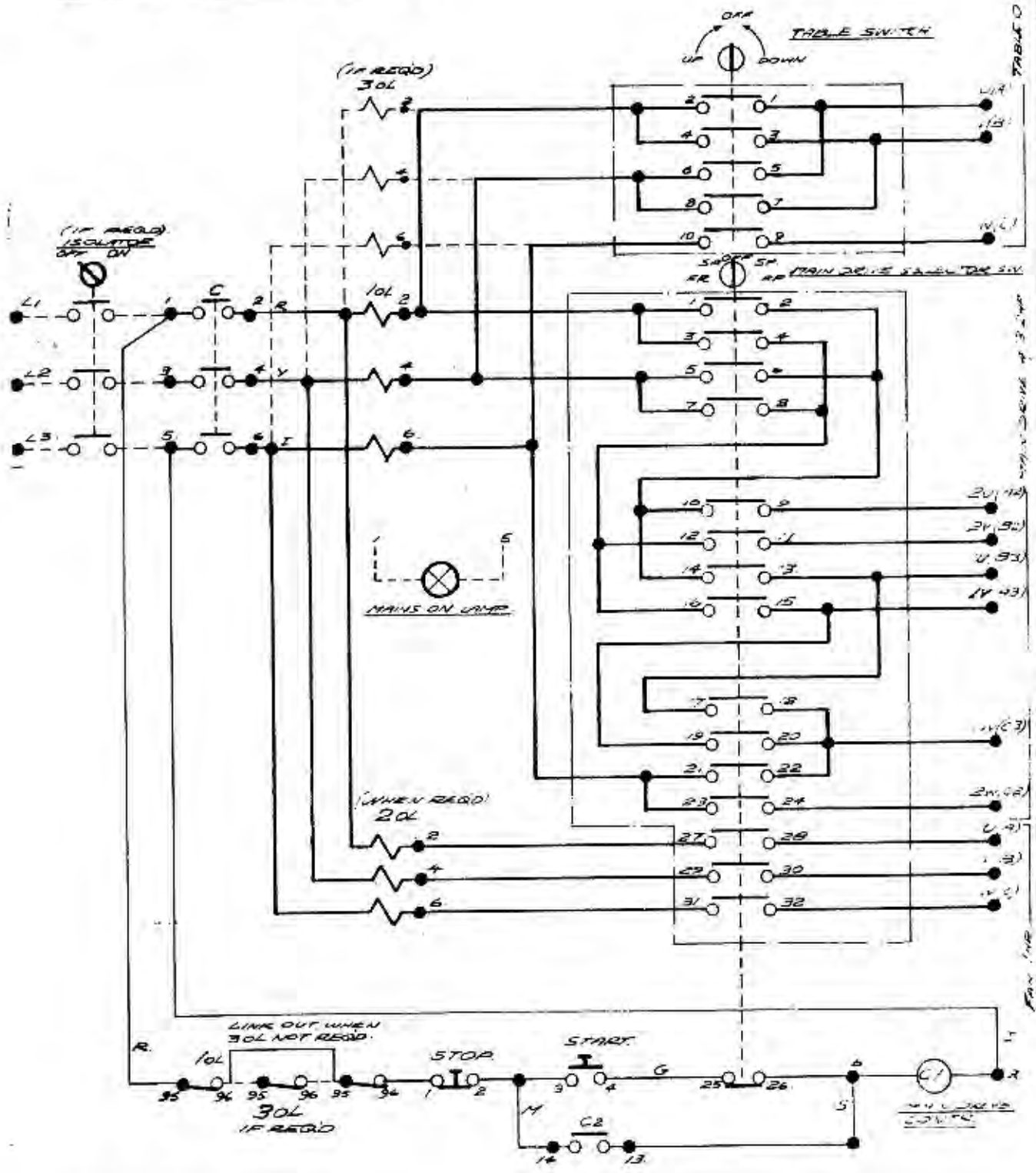

COLOUR CODE.

- R - RED
- Y - YELLOW
- I - INDIGO
- P - PINK
- O - ORANGE
- M - MAUVE
- G - GREY
- S - SIENNA

⑥

ABRASIVE BELTS

For transportation reasons the machine will be supplied without the belt fitted and as such any belts ordered to be supplied with the machine will be packed in separate boxes affixed to the frame.

BELT DIMENSIONS

Model 2500:- 6900 mm (22' 7") x 150 mm (6")

Model 3000:- 7900 mm (25' 11") x 150 mm (6")

The above dimensions, plus the machine model type and serial number must be given when re-ordering belts.

REMOVAL, REPLACEMENT AND TRACKING OF SANDING BELTS

To remove and replace abrasive belts the following procedure should be adopted.

1. Remove belt guard cover A from idler pulley end of machine and swing open dust hood guard B at drive pulley end.
2. Turn hand lever C in clockwise direction to slacken belt until it is possible to lift belt from pulleys and over wooden fence on the oversanding table. On machines with sanding discs fitted to drive pulley, the belt will require lifting over disc back plate, therefore, belt may require slackening further than machines which are not fitted with this feature.
3. Before refitting, it is important that the condition of the replacement belt is checked and found to be in good condition (i.e.) free from cuts, cracks or tears.

RUNNING WITH WORN OR DEFECTIVE BELTS CAN BE DANGEROUS.

4. To replace belt, reverse procedure outlined in point (2) and re-tension by turning handlever C in anti-clockwise direction (DO NOT OVERTENSION, SEE POINT X).

TRACKING

It may be found that after replacement or during the running life of a belt that the track or running alignment requires adjustment in order that the belt runs equally over each pulley and does not tend to 'run-off'.

TO UNDERTAKE THIS OPERATION THE FOLLOWING PROCEDURE SHOULD BE ADOPTED.

1. Remove idler pulley guard cover and by turning the handlever C tension belt to point where all slackness is removed but belt is not fully tensioned as it would be for use under running conditions.
2. Rotate idler pulley by hand and whilst rotating slacken screw D and nut E.
3. Still rotating pulley, turn screw F in either direction until belt is central on width of pulley drive face. At this point re-lock screw D and nut E.
4. Replace all covers and tension belt by turning handle C until there is 4 - 6 mm clearance between shoulder on shaft and casting at point X.

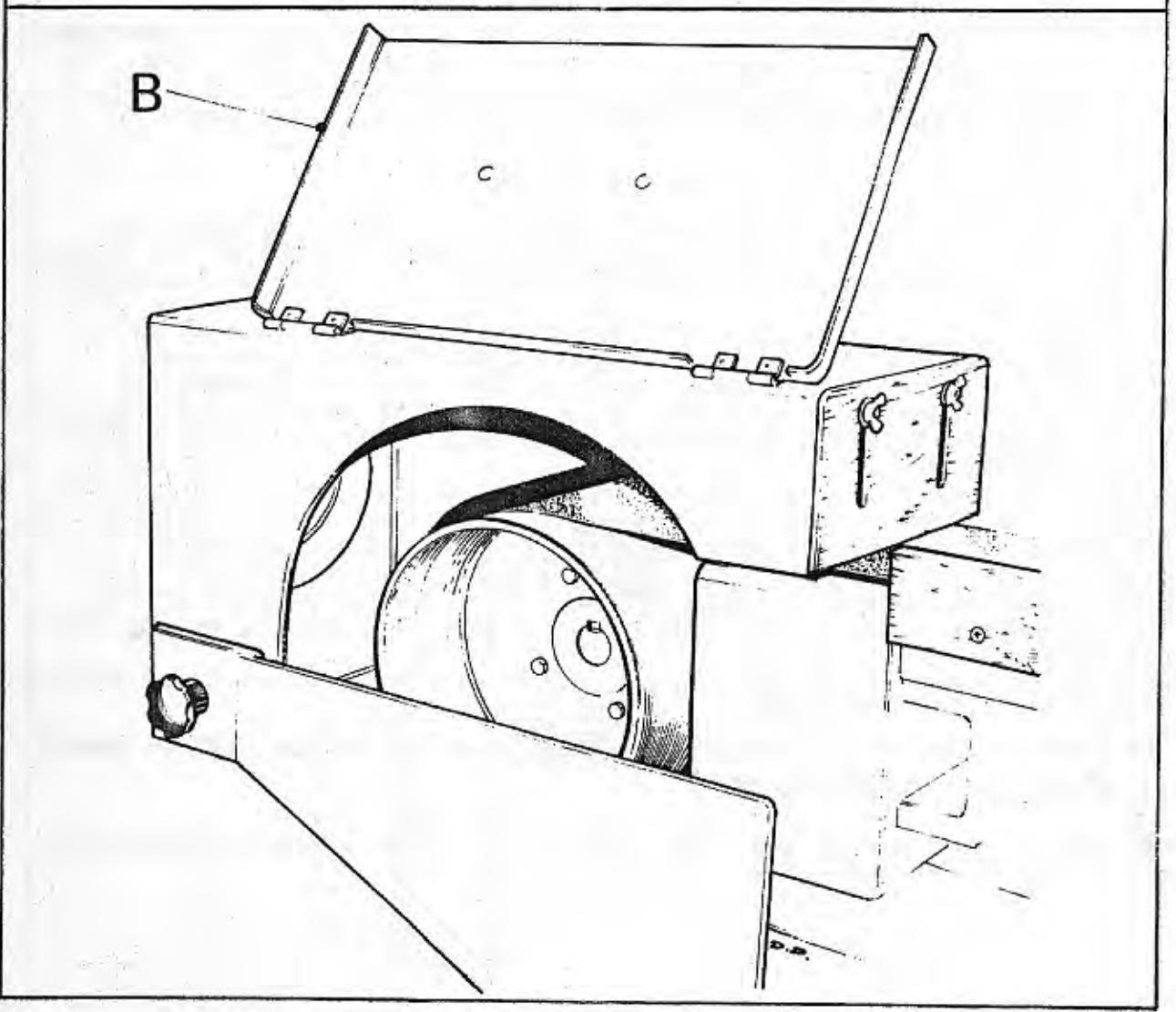
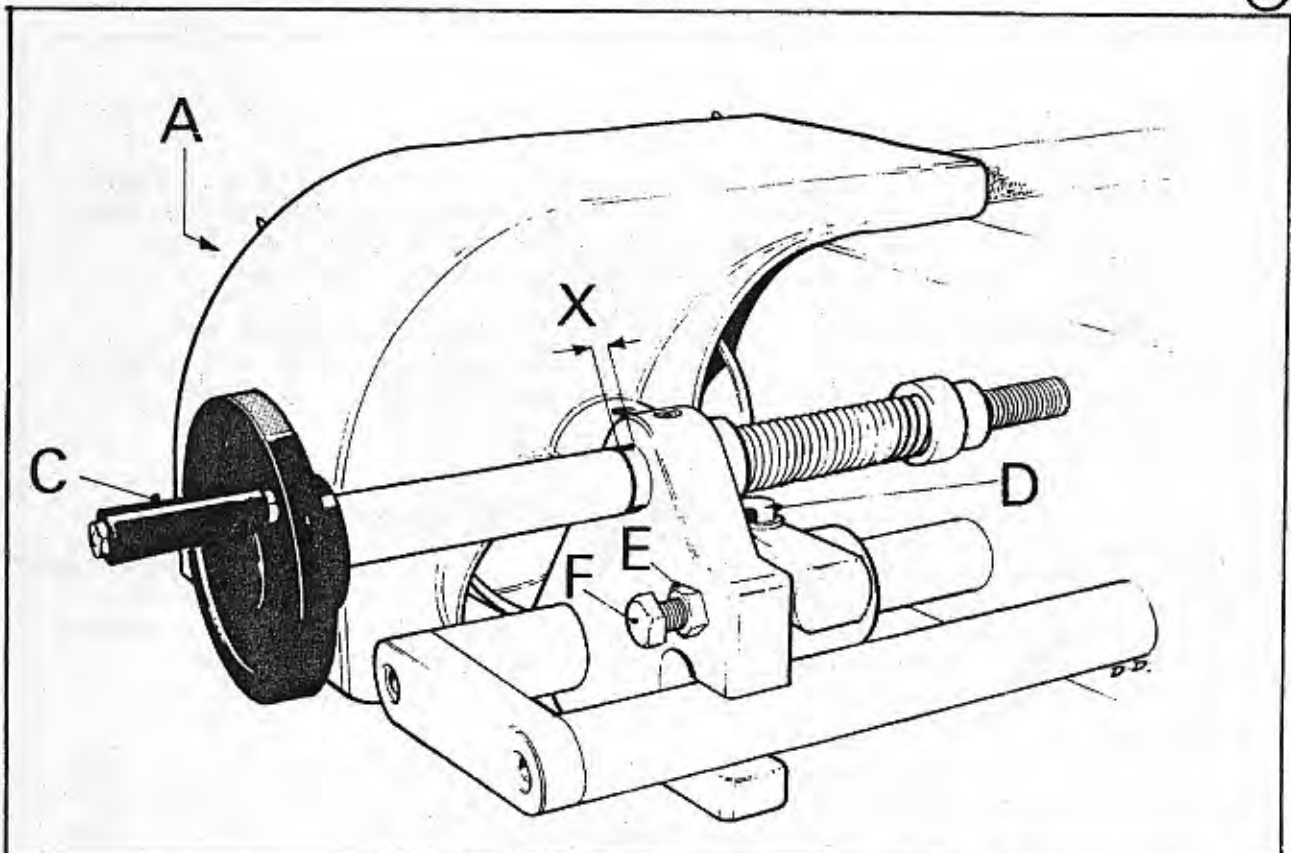

TABLE RISE & FALL

The table rise and fall motion is powered by a .37 kw ($\frac{1}{2}$ h.p.) motor via worm and wormwheel to a rack. A cross-shaft A transmits the drive to the idler pulley end rack, whilst a link collar B allows both pinions to be adjusted to take up the drive against the rack simultaneously.

The worm drive unit is prepacked with heavy duty grease and will require no further attention. However, the teeth of both vertical racks should be periodically cleaned and smeared with lubricant as should the slideways.

RISE & FALL (OPERATION)

To operate the rise and fall press green start button C on main control panel, when pressed the red panel light will illuminate indicating power available at machine. Switch D controls the direction of movement and can be turned to either side of the 'OFF' position towards the indicator arrows on the panel face. The switch is spring loaded and will return to the 'OFF' position when hand pressure is released thereby stopping the motion.

* IMPORTANT *

1. POSITIVE STOPS ARE FITTED AT BOTH TOP AND BOTTOM POSITIONS OF THE RISE & FALL MOVEMENT - WHEN THE TABLE COMES UP AGAINST EITHER OF THESE STOPS RELEASE THE SWITCH IMMEDIATELY TO AVOID DAMAGE TO THE POWER DRIVE.
2. IF IT IS REQUIRED TO CHANGE DIRECTION OF TABLE RISE & FALL MOTION (ie) FROM RAISE TO LOWER OR VISE-VERSA, THE SWITCH WILL PASS THROUGH THE 'OFF' POSITION AND AS SUCH WILL REQUIRE THE START BUTTON C DEPRESSING AGAIN IN ORDER TO CONTINUE IN THE OPPOSITE DIRECTION.

BELT TWO SPEED, FORWARD/REVERSE CONTROL

On a standard machine a two speed directional control switch E is fitted to enable the belt to run in either direction whilst two speeds (15m/sec and 30m/sec) are available in either direction as indicated on the panel.

To start the belt switch E must be in the 'OFF' position then by pressing start button C supply will be available at controls as indicated by panel light. Belt can now be started by turning the switch in the direction of rotation desired as indicated on the panel (ie) CLOCKWISE ROTATION WHEN USING MAIN TABLE, ANTI-CLOCKWISE WHEN USING OVERTABLE.

When it is required to run at the fastest speed the switch should be held in the slow position until speed has built up before switching to top speed. This applies when running in either direction when starting from standstill. For changing direction of rotation (ie) from clockwise to anti clockwise, the switch should be left at the 'OFF' position until rotation has ceased before switching to opposite direction.

When it is required to stop the machine press stop button C and return switch E to 'OFF' position.

THE ABOVE POINTS SHOULD ALWAYS BE OBSERVED TO ELIMINATE RISK OF DAMAGE TO MOTOR AND ABRASIVE BELTS.

On single speed models the above points in the main apply especially when changing direction of rotation.

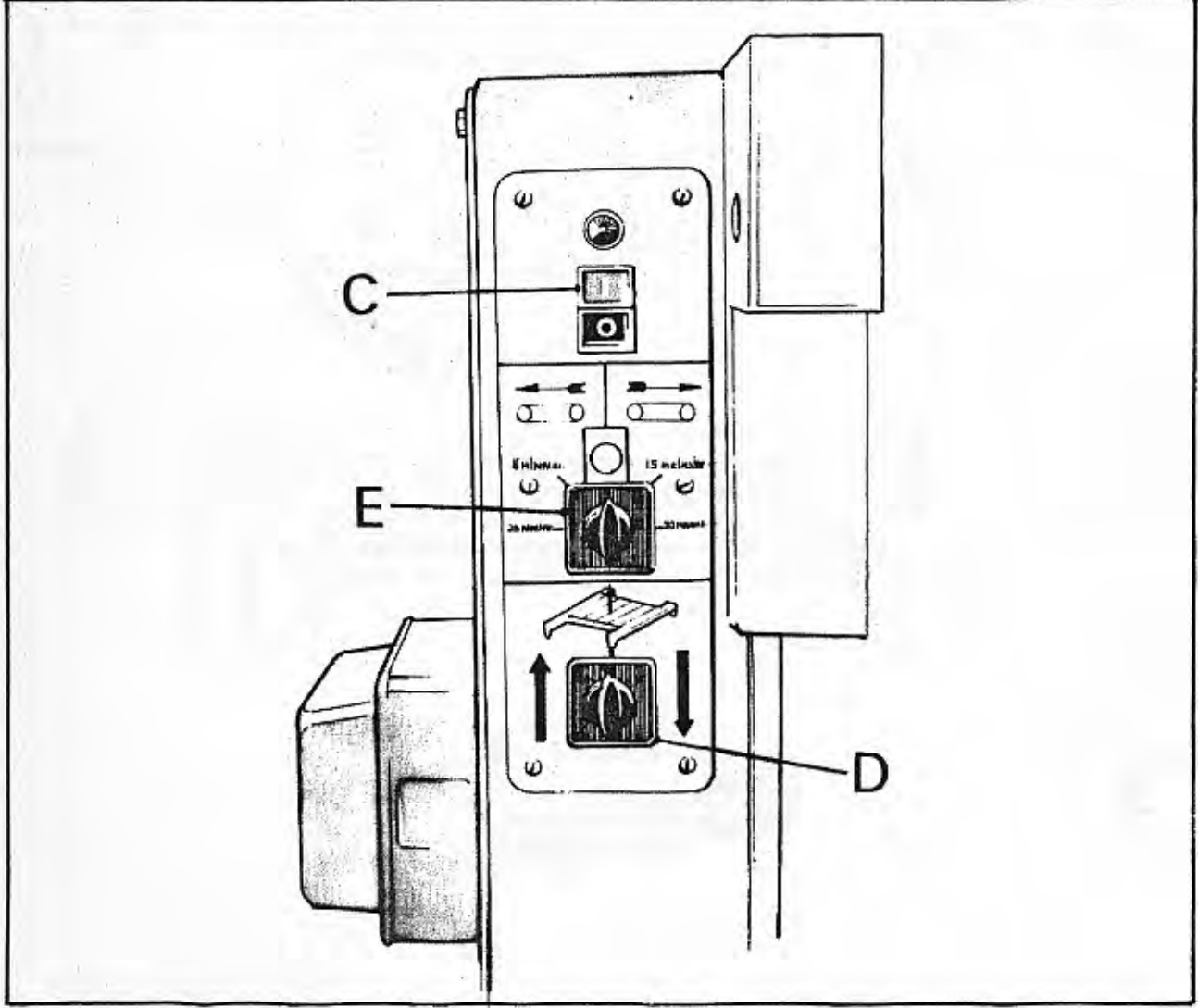
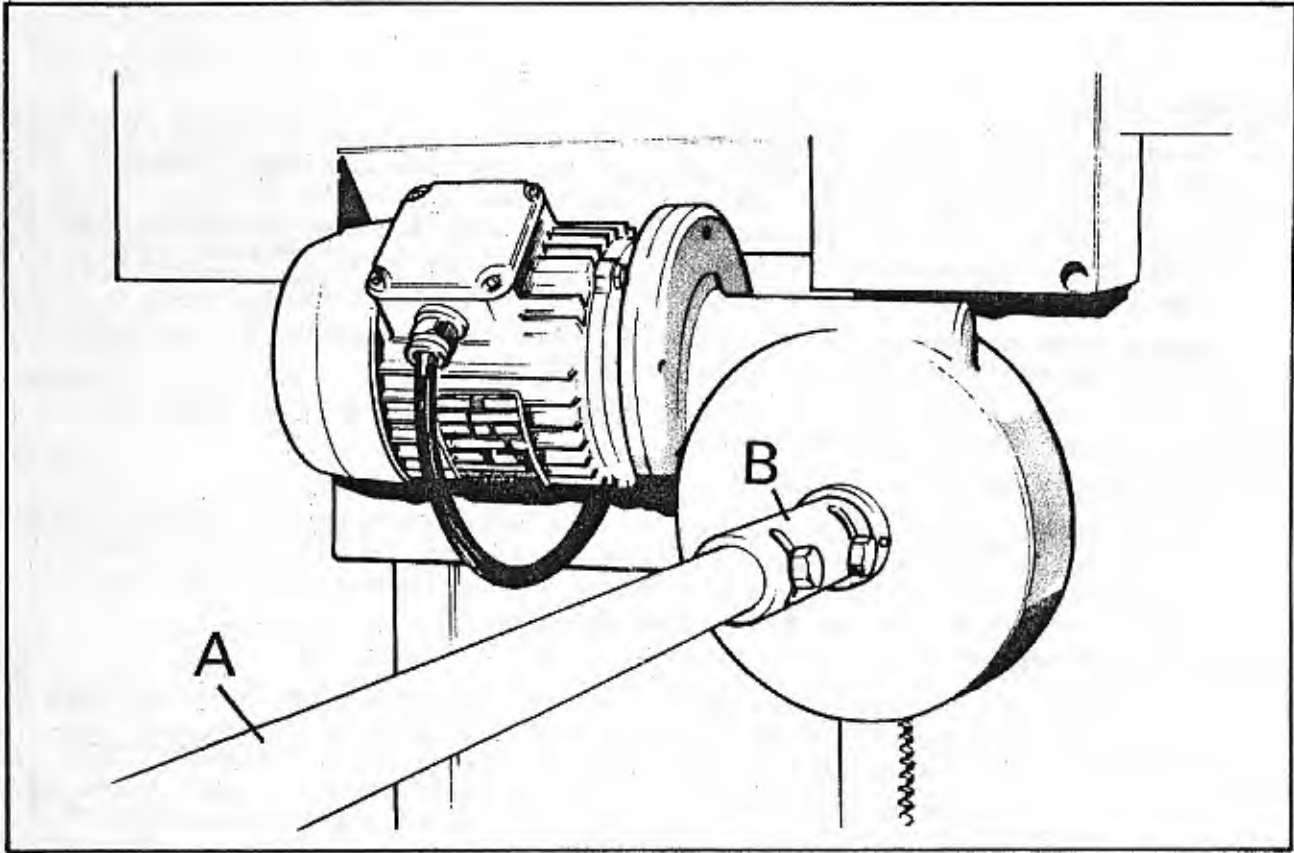

SANDING TABLE

The sanding table frame is supported on two slide bars A which in turn run between nylon guide rollers mounted on sealed bearings. Each slide bar runs between four rollers, the lower pair B being on concentric shafts whilst the top pair C are mounted on eccentric shafts to facilitate adjustment. These rollers have been set correctly prior to despatch and should not require any further attention.

To ensure smooth running of the table clean the slide bars regularly to prevent resin build-up DO NOT OIL BARS.

Nylon brush wipers D are fitted at either end of the slide frames, these should be replaced when worn.

TABLE WOOD PIECES

The table woods are simply screwed to the metal framework of the table and are manufactured from high quality hardwood. Replacement pieces can be supplied to order or made from any similar material with a section of 20 mm x 70 mm x 800 mm in length.

WOODEN TABLE FENCE

A wooden table fence is supplied to provide a datum stop for the workpiece. It is designed to drop between the table wood pieces and can therefore be positioned in any space along the table. However, for best results and improved extraction the fence should be positioned at the nearest point to the fan extraction chute and the workpiece butted upto it as illustrated at point E.

Replacement fence pieces can be supplied to order or made from good quality hardwood of the sectional dimensions shown be

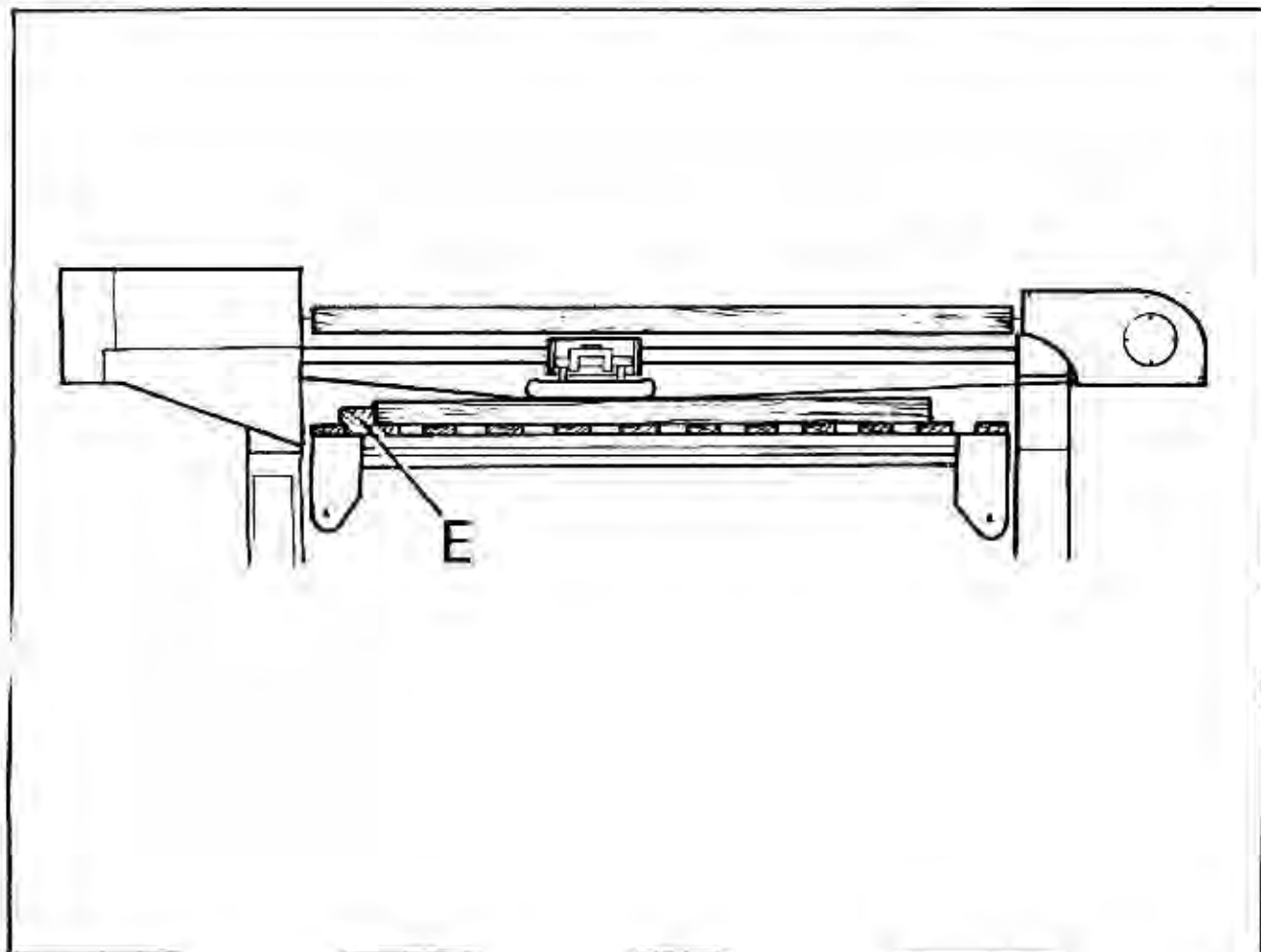

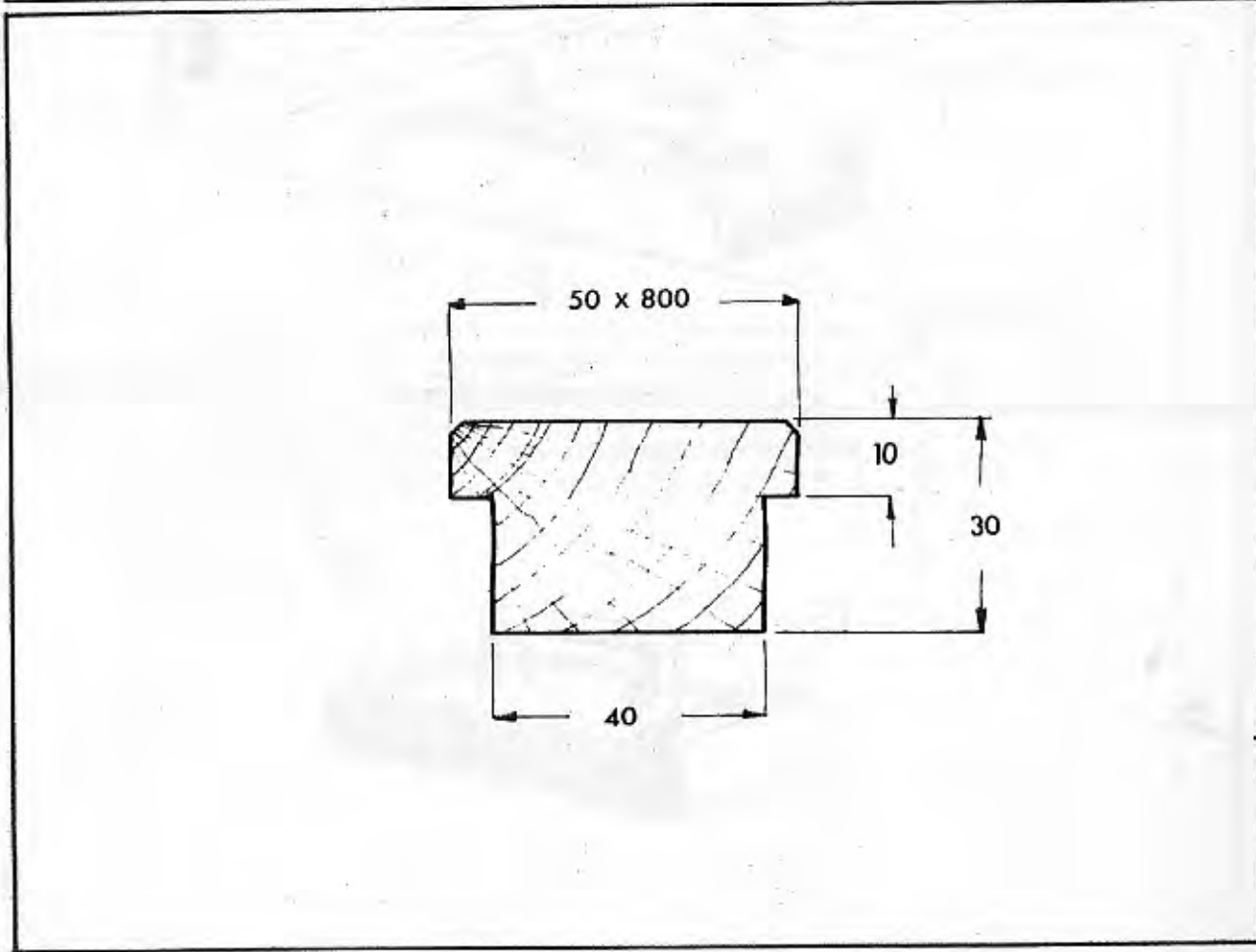
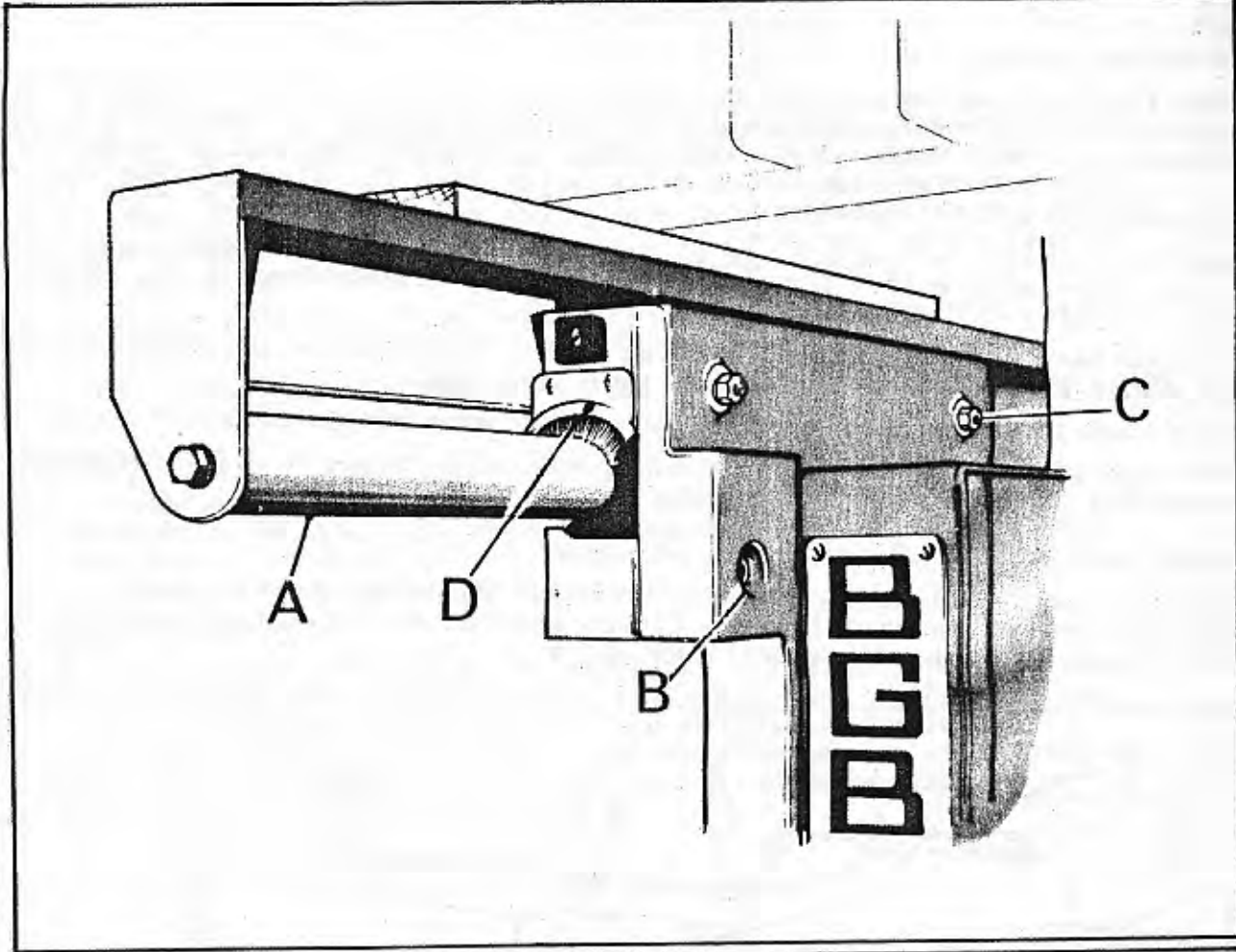

FLOATING SANDER PAD

The floating pad is mounted on sealed bearings within the bearing housing A. Each bearing is mounted on an eccentric pin which has been adjusted prior to despatch to give easy movement, and should require no further attention less that of ensuring that the floating pad bar B is kept clean and lightly oiled.

The whole unit is operated by a long counter-balanced handle C and the counter-balance weight D is adjustable by unlocking screw E, to suit the operator.

The contact pad F is fitted with an anti-friction material which can be replaced by removing the two retainer strips G.

Replacement anti-friction material can be supplied to order.

The contact pad F can be adjusted by unlocking screw H and sliding the mounting bracket along the handle arm.

HAND SANDER PAD

A small hand held sanding pad is supplied for work on intricate workpieces. This unit is also fitted with an anti-friction surround which can be replaced as outlined above.

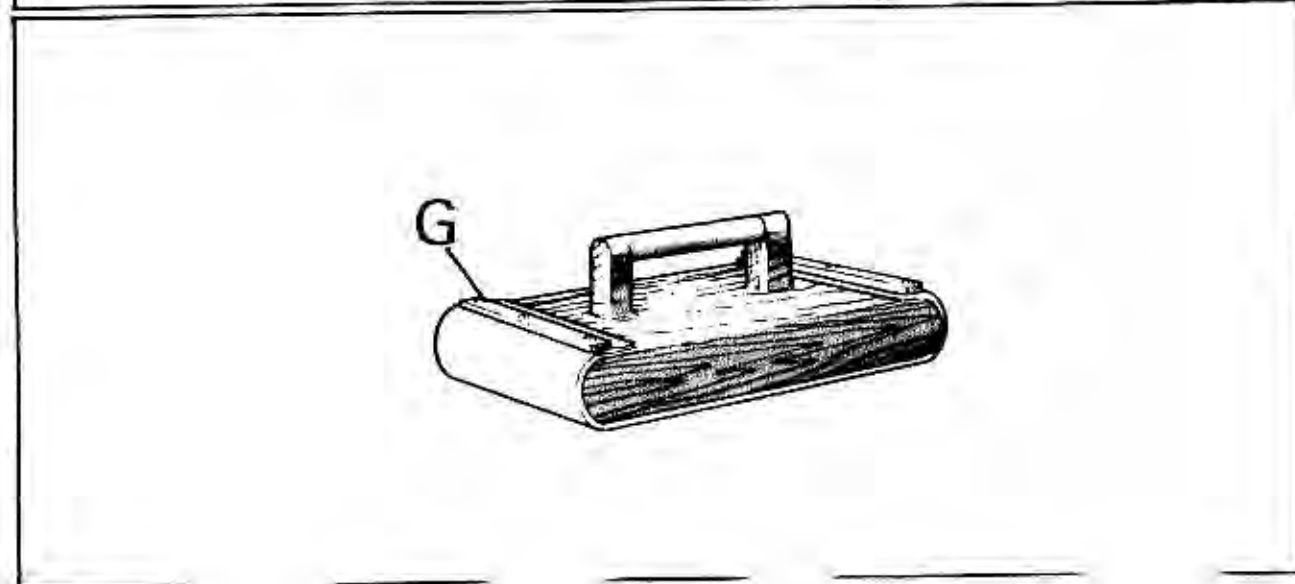
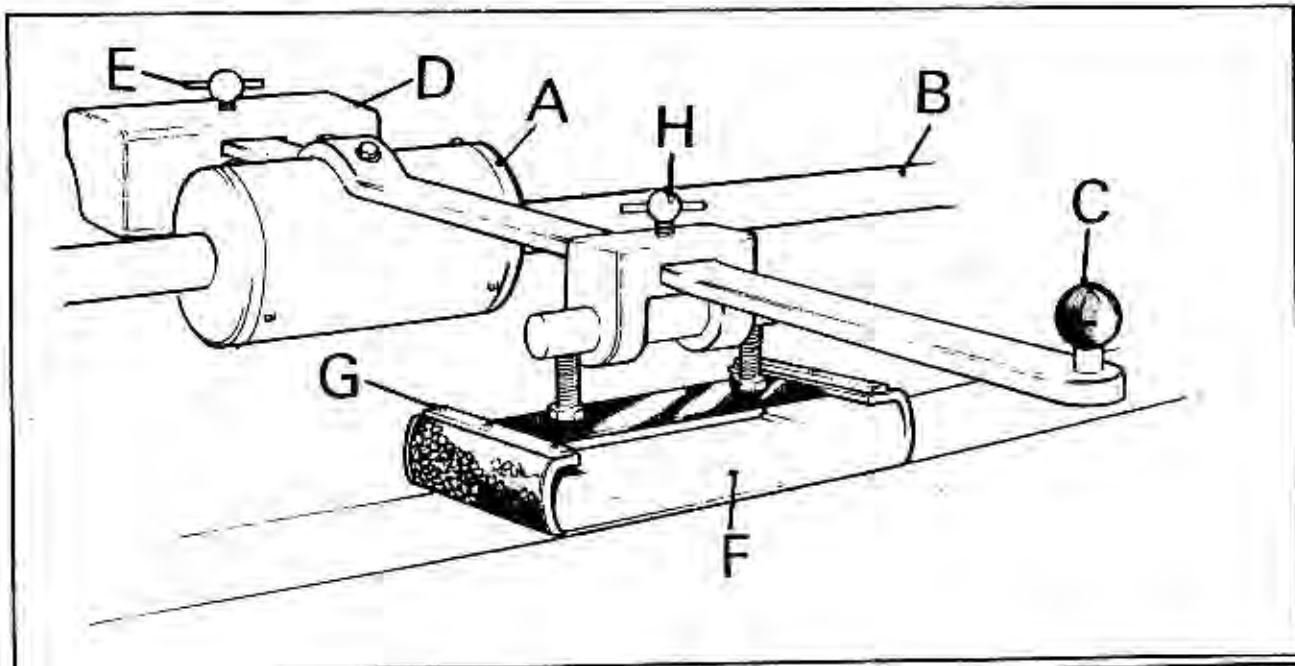

OVER SANDING TABLE

The over sanding table is useful for a variety of light sanding work such as drawers and many other box forms. It should be, however, remembered that the direction of belt rotation must be changed by means of the two speed directional control switch previously mentioned and that all work should be undertaken as near to the dust hood as possible to ensure maximum extraction. At the exhaust hood aperture it will be noticed that an adjustable wood baffle A is fitted which should remain within 8 to 12 mm of the belt at all times.

IMPORTANT:- BELT ROTATIONAL DIRECTION WHEN USING OVER TABLE IS ANTI CLOCKWISE.

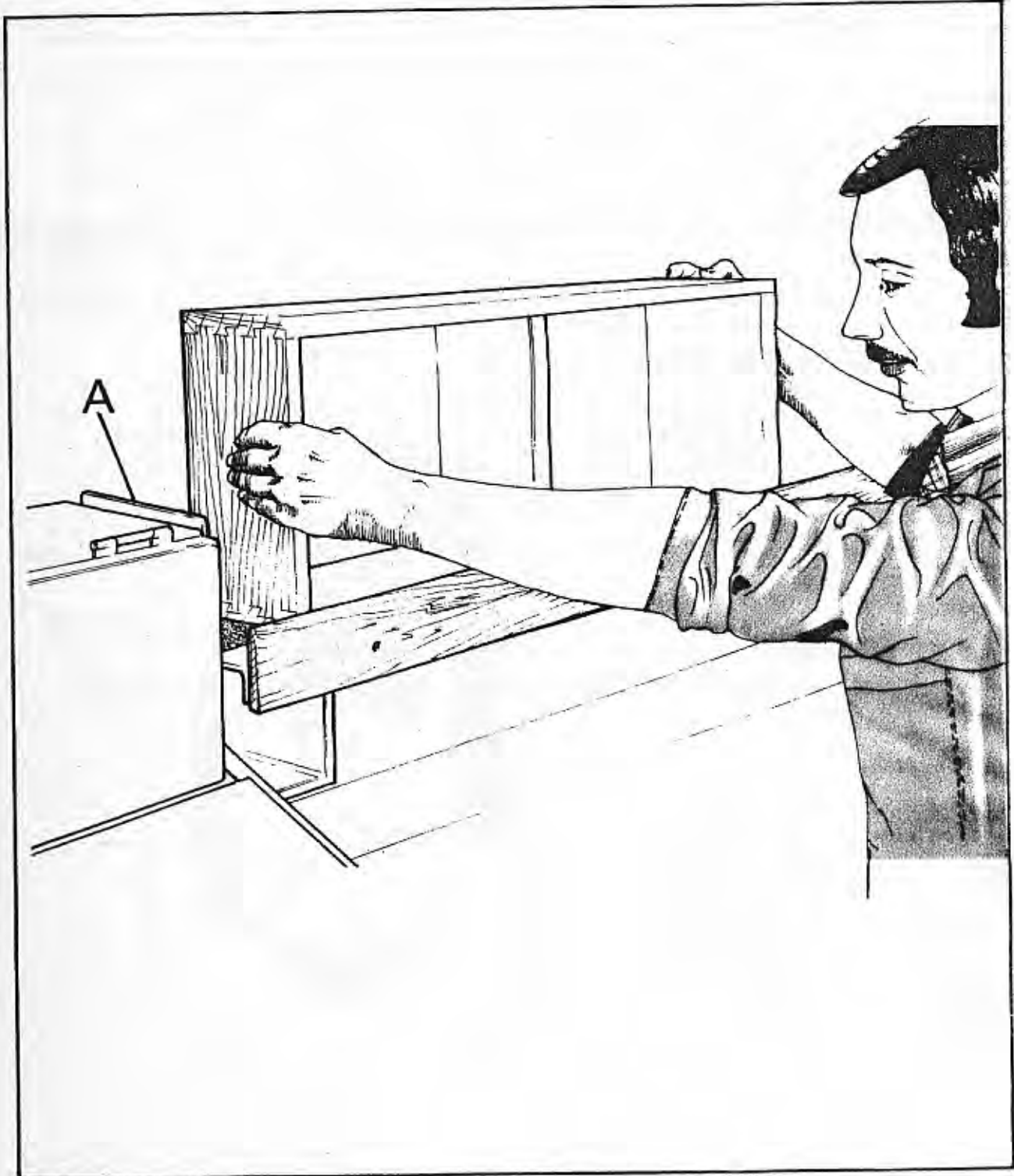

DUST EXTRACTION (DUST HOODS, FAN UNIT ETC.)

Good extraction is important and as such both models of BGB can be offered to suit your requirements in this area.

1 MACHINE FOR CONNECTION TO EXISTING FACTORY DUST SYSTEM

In this case the machine is supplied without a self contained motorised fan unit, but simply an adaptor at the driven pulley end of 150mm dia., which is for connecting to your existing exhaust system (see fig.A)

2 MACHINE TO BE USED IN CONNECTION WITH DUST COLLECTING UNIT

Where the machine is to be used with a collecting unit either existing or of our manufacture the machine will be supplied with the motorised fan unit (see fig.B). The collector unit of Bursgreen manufacture consists of a steel cabinet and connecting pipes. Within the cabinet a canvas bag is hung vertically to collect the dust residue. The system works as follows, when the machine is running the pressure of air moved through the pipe to the collector by the fan inflates the bag but does not trap the air in as much as the air can pass freely through the fibre of the canvas but dust particles cannot, this becoming trapped within the bag and being collected there. The bag requires emptying when it is approximately 50 - 60 % full and should not be allowed to overflow as this will reduce the collectors efficiency. To remove the bag release the webbing strap at the neck of the main inlet inside the cabinet.

3 MACHINE TO BE USED WITH MOTORISED COLLECTION UNIT

Where ordered the machine will be supplied without the fan unit but simply an adaptor, as outlined in part 1, for connection to a motorised unit. Detailed operating and service instructions are supplied with the unit.

Technical details worthy of note on the above unit are:-

DUST CONTAINER CAPACITY -----	4 cu.ft.
FILTER AREA -----	67 sq.ft.
PERFORMING CAPABILITY (NORMAL CONDITIONS) -----	6.5" W.G. at 300 C.F.M

NOTE:- AT NORMAL SERVICE PERIOD CLEAN FAN, PIPES OR DUCTS ETC. OF ANY DUST BUILD-UP WHICH HAS ADHERED TO THESE COMPONENTS.

OBSERVE MANUFACTURERS SERVICE & CLEANING INSTRUCTIONS FOR COLLECTOR UNITS STRICTLY.

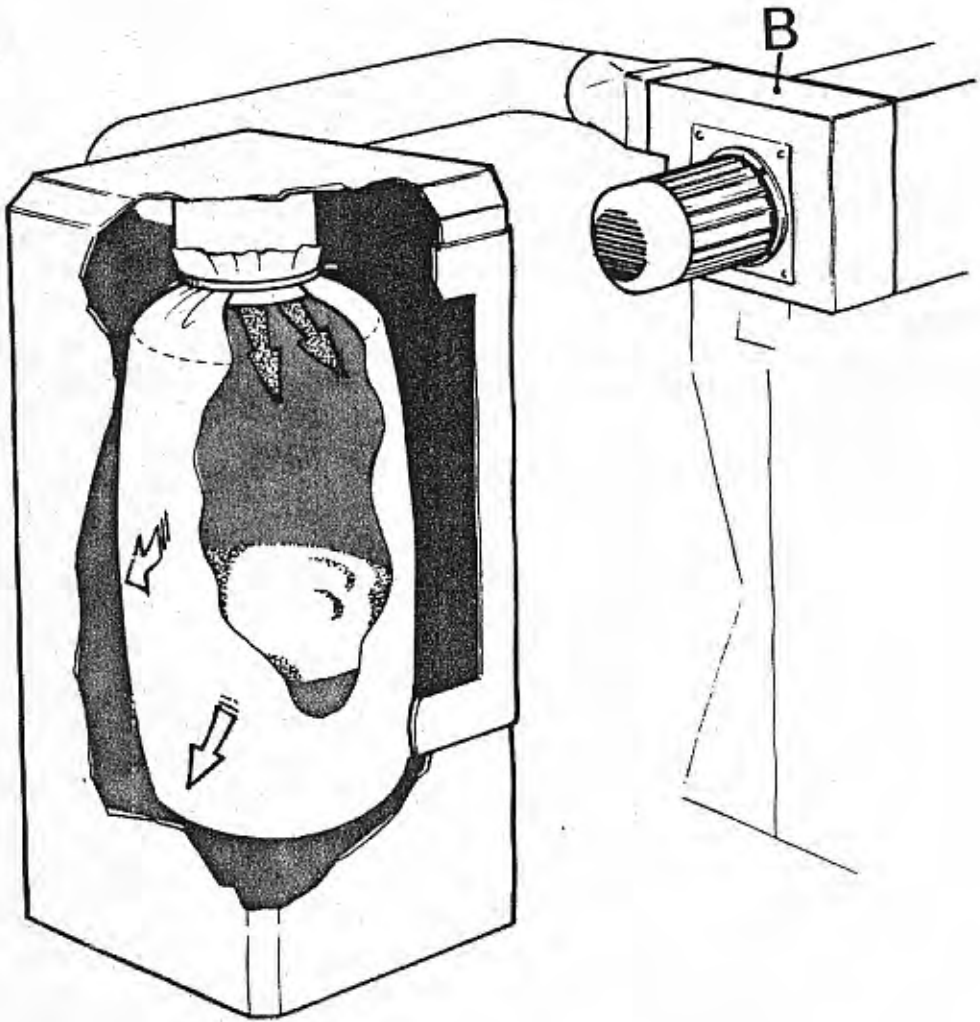
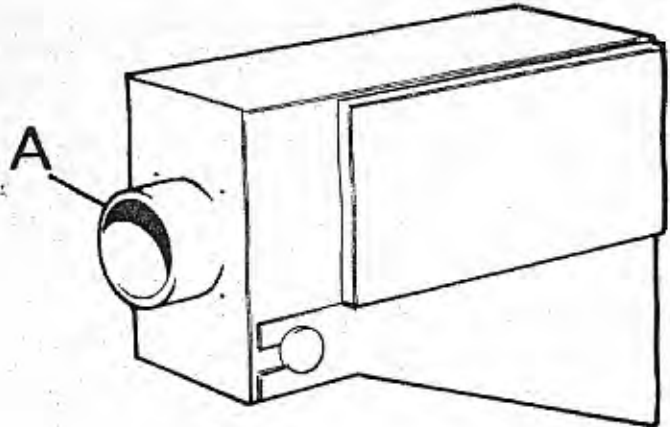

ABRASIVE BELTS & DISCS AVAILABLE

Please note when ordering belts state size of machine. Both belts and discs are sold in packs of ten of each grade only, therefore, prices given upon application for quote will be per pack.

350 MM (14") DIA. DISCS

Aluminium oxide paper backed grit	0	-	80
.. .. .	½	-	60
.. .. .	1	-	50
.. .. .	1½	-	40
.. .. .	2	-	36

150 MM (6") WIDE BELTS (PAPER)

Aluminium oxide paper backed grit	4/0	-	150
.. .. .	2/0	-	100
.. .. .	0	-	80
.. .. .	½	-	60
.. .. .	1	-	50
.. .. .	1½	-	40
.. .. .	2	-	36

150 MM (6") WIDE BELTS (CLOTH)

Aluminium oxide cloth backed grit	4/0	-	150
.. .. .	2/0	-	100
.. .. .	0	-	80
.. .. .	½	-	60
.. .. .	1	-	50
.. .. .	1½	-	40
.. .. .	2	-	36

ROLLS OF 150 MM (6") WIDE ABRASIVE 50 M (165') LONG

Available in Aluminium oxide paper backed only, are available in grits 150 down to 36. The above is intended for use with sanding bobbins and where the facility is available for making ones own belts.

FOR PNEUMATIC SANDING BOBBINS

Three sizes of bobbin are available 63 mm dia. (2 5/8"), 75 mm (3") dia, 100 mm (4") dia. Please state size required when ordering. Each grit is sold in packs of ten.

Aluminium oxide cloth sleeves grit	0	-	80
.. .. .	½	-	60
.. .. .	1	-	50

EXTRA ITEMS

EXTRA ITEMS

DISC & CANTING TABLE

The disc attachment complete with canting table is suitable for square bevel and external radii work. The angle of the cant is easily set as desired and can be locked rigidly in place by nut A.

The angle of the cant can be set 45° down and 10° up from horizontal and is limited at each of these points by the slot in the pivot bracket B.

The disc is 350 mm in dia. (14") and is secured to the driven pulley by means of an adaptor, which fits directly to the pulley via the existing mounting bolts, and by a central cup head bolt C. The drive between the belt pulley and disc is assured by the fitment of a peg and slot cut into the outer surface of the belt pulley (see inset).

Where the above unit is supplied at a later date than the machine (ie) not a factory fitted extra, the following procedure should be adopted for installation.

The unit supplied will comprise of the Disc table (BGB 83)'D' Disc table quadrant (BGB 82)'B' Disc quadrant guide (BGB 98)'E' plus the required studs and screws and lock nut; along with the disc and adaptor mentioned above.

- 1 - Remove pulley mounting bolts F and refit with adaptor (BGB 4)'G'.
- 2 - Offer disc H to pulley and mark position of drive peg cutout (see inset) 6 mm wide slot ($\frac{1}{4}$ ").
- 3 - Secure disc H to pulley with 12 mm bolt C.
- 4 - All holes for mounting the canting table are drilled on the endframe (see illustration).
- 5 - Screw quadrant guide 'E' to endframe with the three M5 x 20 countersunk allen screws provided I.
- 6 - Lock M12 x 60 stud J into hole provided.
- 7 - Place disc table and quadrant 'D' and 'B' onto guide and over stud and secure with M12 locknut A and spring washer provided.
- 8 - Check that the correct angles to which the table can be canted are obtainable.

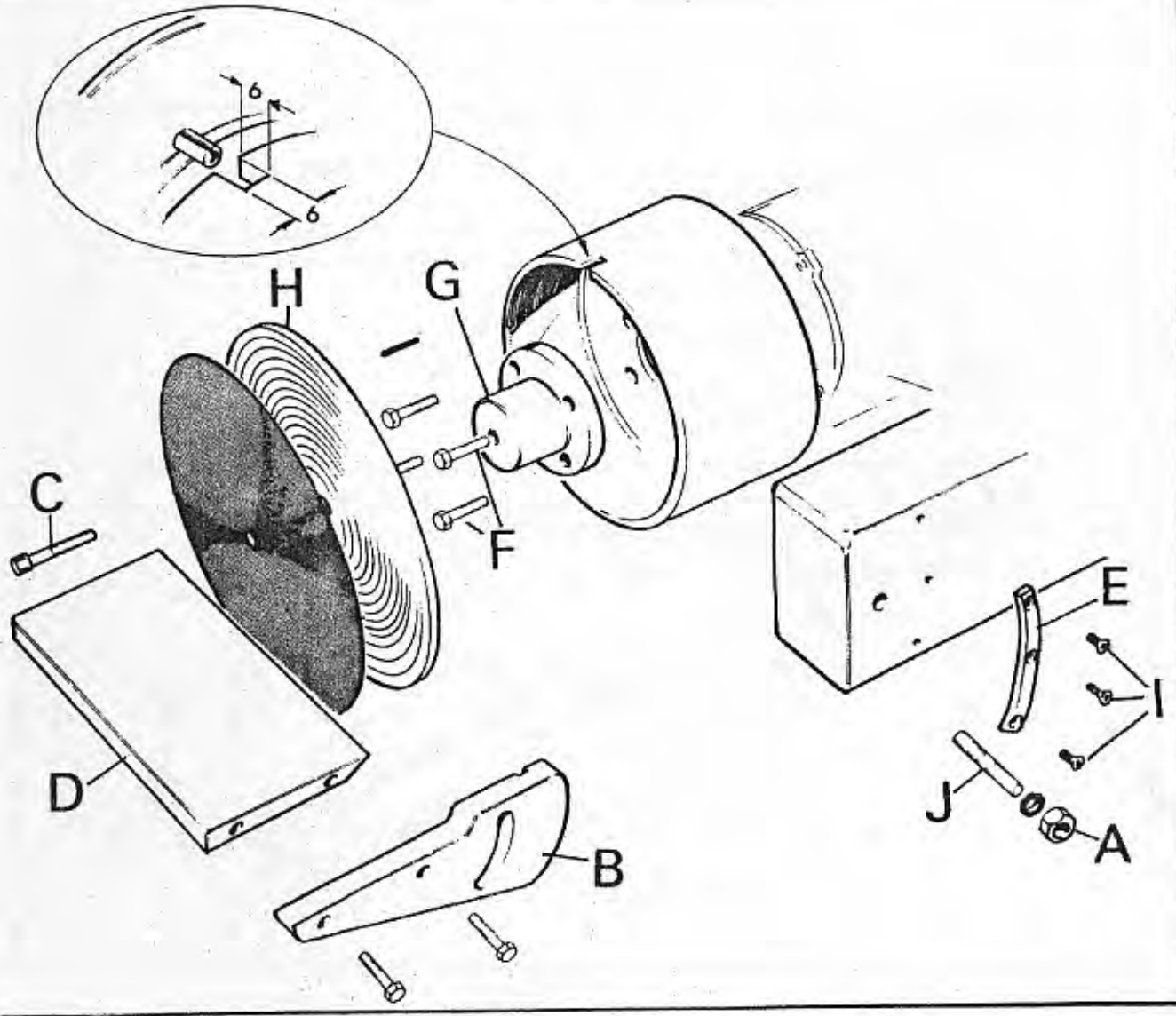
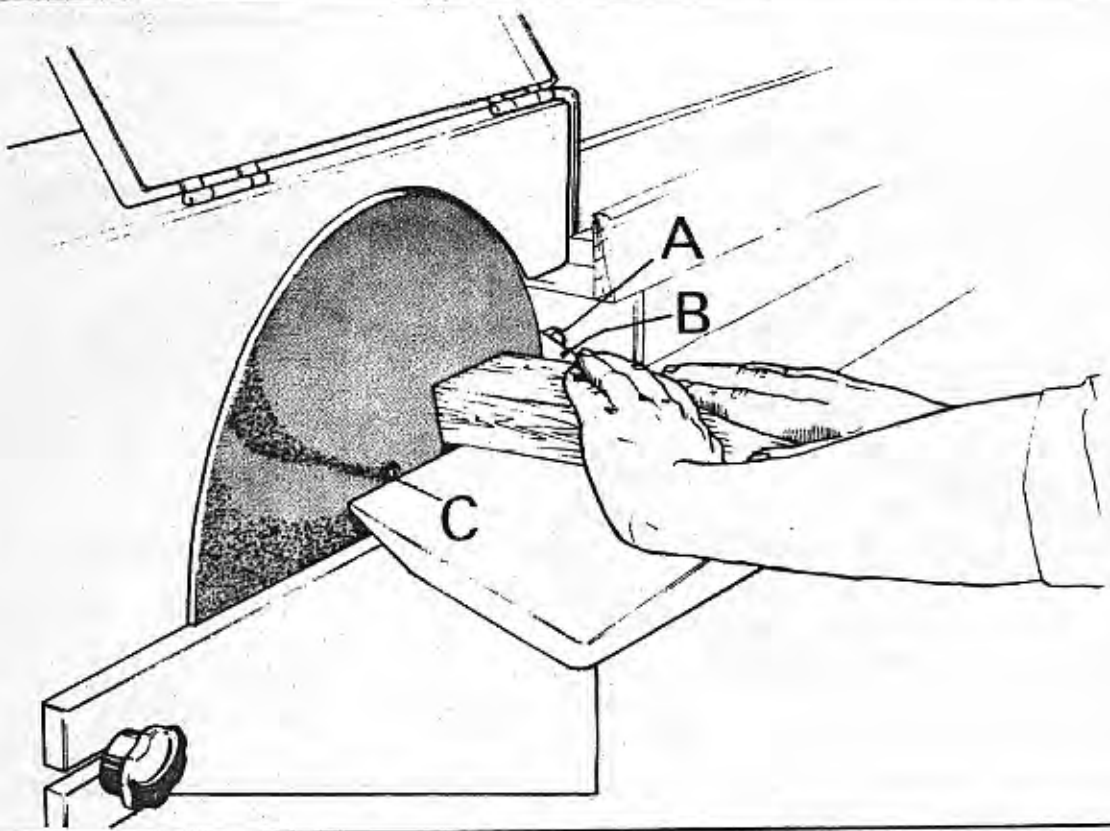

WOOD AND PNEUMATIC SANDING BOBBINS

As an additional feature to the machine the bobbin attachment provides efficient sanding for a variety of work. Fitted to belt idler pulley the adaptor spindle A accepts the following bobbin sizes.

75 mm (3") DIA. , 100 mm (4") DIA. , 150 mm (6") DIA.
x 150 mm (6") LONG WOOD BOBBINS.

75 mm (3") DIA. , 75 mm (3") DIA. , 100 mm (4") DIA.
x 177 mm (7") LONG PNEUMATIC BOBBINS.

As both types utilise the same adaptor spindle it is possible to interchange the two types as desired with the aid of the special collars B & E provided

If the above feature is not a factory fitted item simply follow the procedure given below.

- 1 - Remove idler pulley guard cover.
- 2 - Remove idler pulley bearing endcap C.
- 3 - Directly replace endcap C with adaptor spindle A using bolts previously removed and lock in place.

The illustration overleaf illustrates the adaptor collars required for mounting both types of bobbin.

REPLACEMENT OF ABRASIVE ON WOOD BOBBINS

- 1 - Slacken and remove nut D.
- 2 - Draw collar E from spindle along with bobbin.
- 3 - At this point it is possible to pull bobbin in half and remove old abrasive paper.
- 4 - Wrap new piece of abrasive paper round body of bobbin and tuck ends down between bobbin halves.
- 5 - Close bobbin and replace on spindle locking up with nut and tapered collar. The taper on the bobbin and collar causes the unit to clamp together when tightened.
- 6 - Check that abrasive is firm before running.

PNEUMATIC BOBBINS

- 1 - Do not remove bobbin from spindle, simply de-flate by pressing centre pin of air valve F.
- 2 - When deflated simply slide off sleeve and replace with a new one.
- 3 - Ensure new sleeve is positioned equally on bobbin then inflate, to grip the sleeve, to a pressure of 1 kg/cm² (14 lb/in²)
- 4 - Check air pressure in bobbin daily.

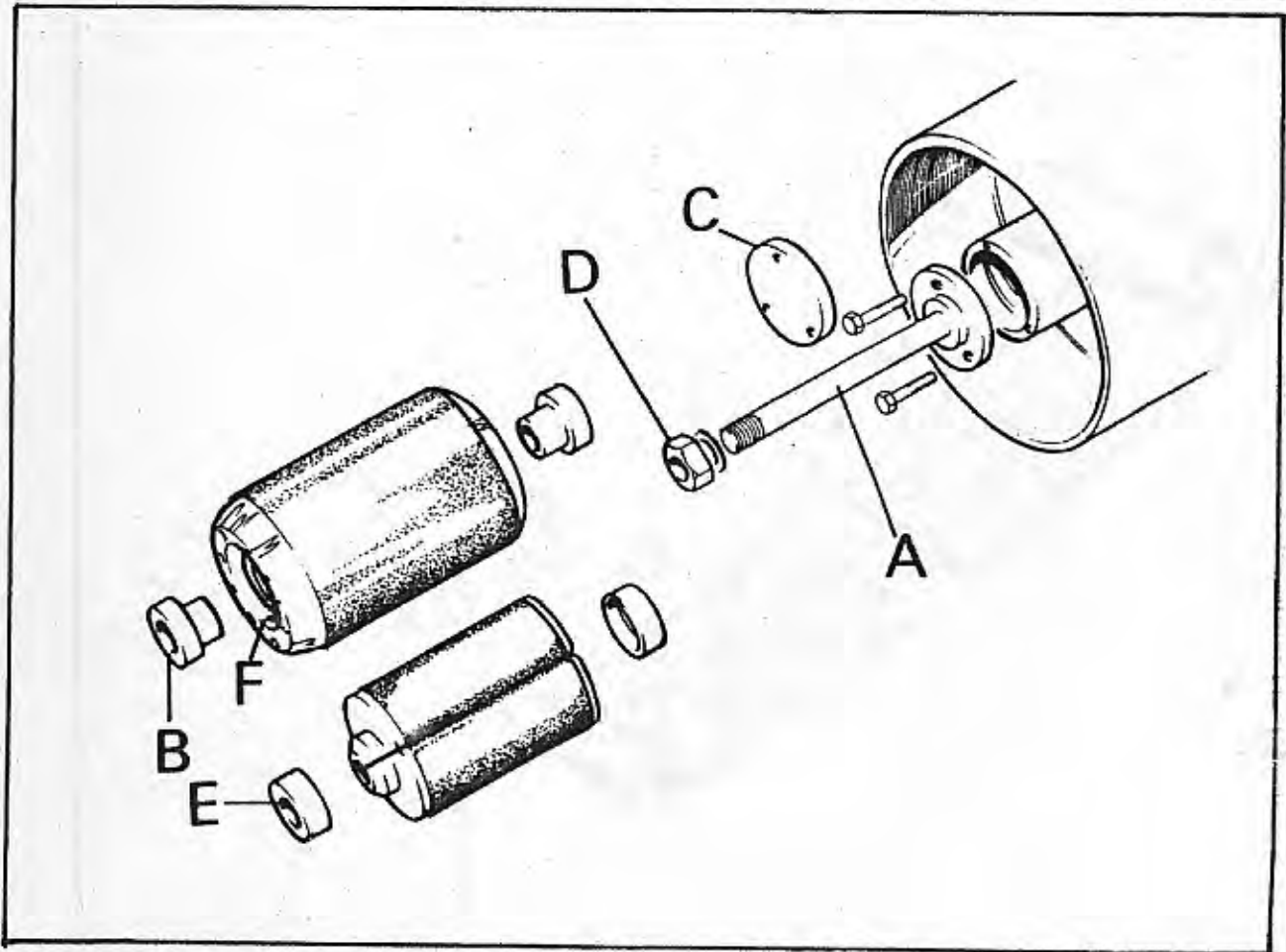
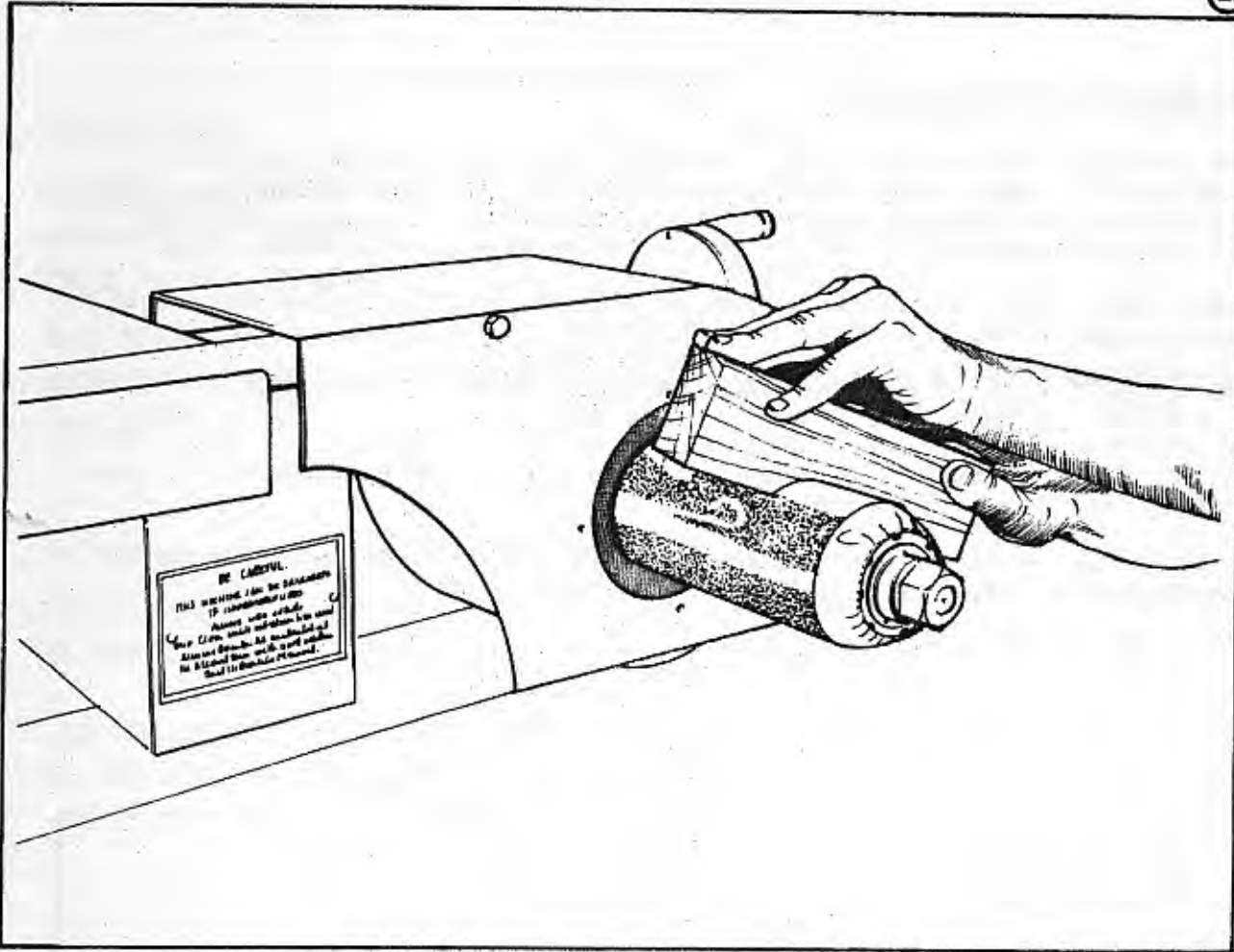

INTERMEDIATE PRESSURE BELT

This feature reduces the 'drag' between the floating pad and the abrasive belt thus increasing control of the pad when operating. The belt which runs from either end of the pressure is made of special anti-friction material and is replaceable as an individual item.

If the above unit is not supplied as a factory fitted item see details given below.

NOTE:- STATE SIZE OF MACHINE WHEN ORDERING SERVICE OR SPARES.

Kit of parts supplied will include two mounting blocks 'A', one slotted shaft assembly 'B', one link and pivot shaft assembly 'C' plus the belt and plate spring made up 'D'.

The above parts should be assembled as illustrated below and mounted via the predrilled holes in the machine end frames.

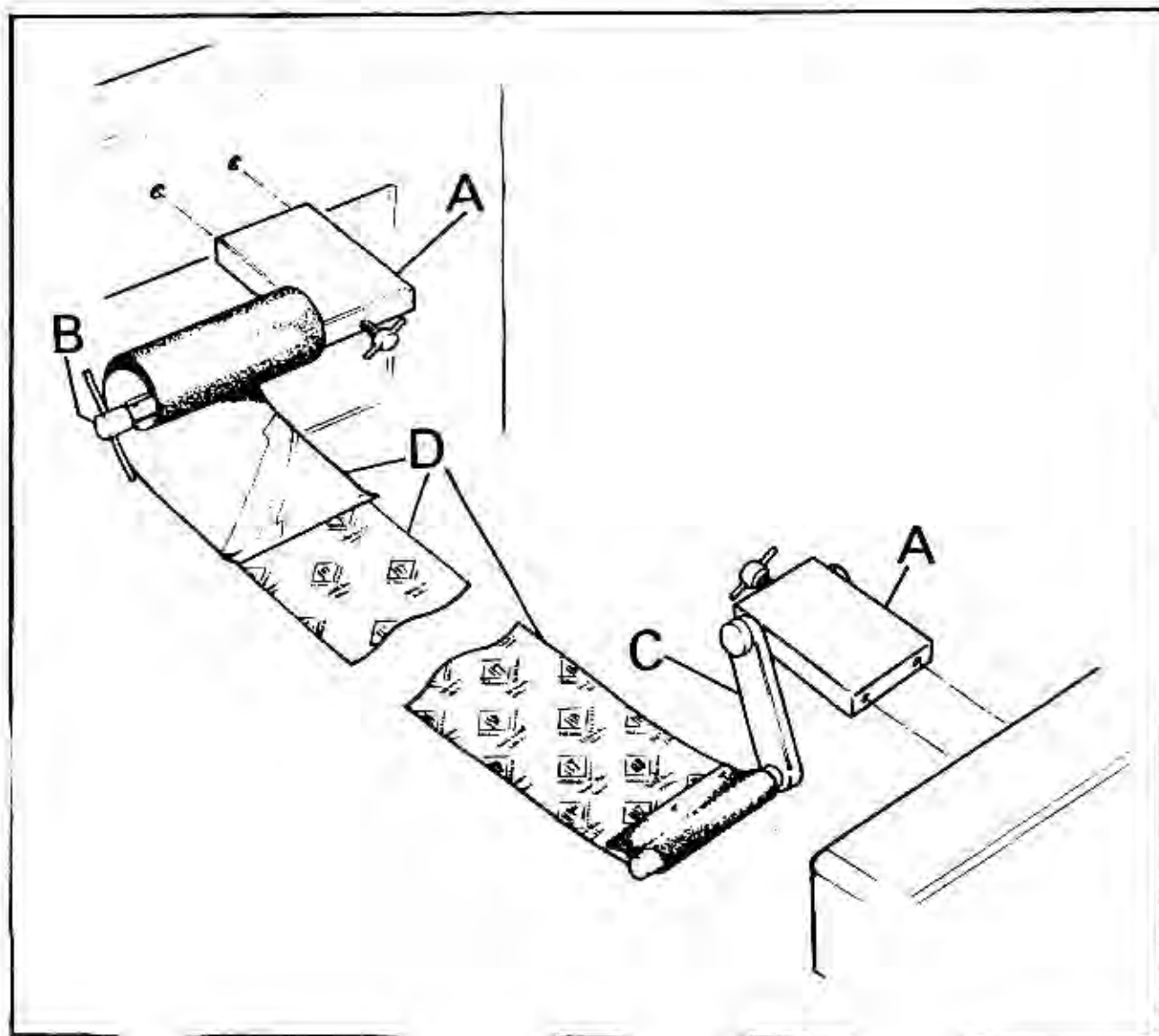

RECOMMENDED SPARES STOCK LIST

DESCRIPTION	QTY.	PART No.
TABLE ROLLER BEARINGS	16	SKF 6201 2RS
FLOATING PAD BEARINGS	6	SKF 6001 2RS
IDLER PULLEY BEARINGS	2	SKF 6205 2RS
ANTI FRICTION MATERIAL	TO ORDER	150 mm WIDE 3m NYLON <i>100</i>
BELT FOR INTERMEDIATE PRESSURE	1	150 mm WIDE x (STATE M/C SIZE)
HARD WHITE FELT	TO ORDER	150mm WIDE (FORWOOD BOBBINS)

ELECTRICAL SPARES STANDARD VOLTAGE ONLY

ROTARY SWITCH FOR TABLE	1	C10 8AV 825 (UK. SOL) <i>K7040751</i>
ROTARY SWITCH FOR BELT	1	C17 8AV 753 (UK. SOL) <i>K7040759</i>

FOR ANY OTHER TYPE OF STARTING, CONTACT BURSGREEN (COLNE) LTD.,
GIVING FULL PARTICULARS OF YOUR MACHINE.

