



Metric / Imperial

Dust Collection Hole x Suggested Power

Ø125mm / Ø5" x 5HP

Pressure Roller / Dia.

8pcs / Ø70mm / Ø2.8"



- Dual Chain Conveyor
- Cast Iron Guide Rails
9 V-shaped Ways

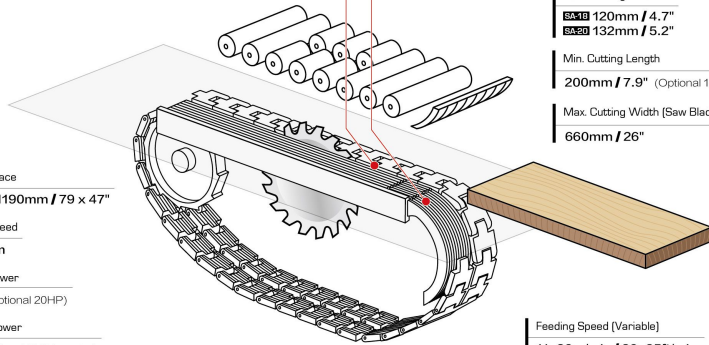

Table Surface

2000 x 1190mm / 79 x 47"

Spindle Speed

3000rpm

Spindle Power

15HP (Optional 20HP)

Feeding Power

2HP (Optional 2HP Inverter)

Saw Blade Dia. x Bore

Ø355-510mm x 50.8mm / Ø14-20" x 2"

Machine Size [L x W x H]

SA-18 2220 x 1550 x 1510mm / 87 x 61 x 59"

SA-20 2220 x 1550 x 1530mm / 87 x 61 x 60"

Packing Size [L x W x H]

2270 x 1680 x 1750mm / 89 x 66 x 69"

N.W. / G.W.

1635 / 1700kg / 3600 / 3750lbs

Max. Cutting Thickness

SA-18 120mm / 4.7"

SA-20 132mm / 5.2"

Min. Cutting Length

200mm / 7.9" (Optional 150mm / 5.9")

Max. Cutting Width [Saw Blade's Right Side]

660mm / 26"

Feeding Speed [Variable]

11-26m/min / 36-85ft/min

Feeding Speed [Inverter]

11-26m/min / 36-85ft/min (Optional)



STRAIGHT LINE EDGERS
ADVANCED SERIES

PU-18 XP
PU-20 XP

Wadkin
BURSGREEN



www.advancedmachinery.co.uk

Advanced Machinery Services Ltd
Skeffington Mill,
A47 Uppingham Road,
Skeffington, Leicestershire, LE7 9YE

Phone: 0844 844 9949
Fax: 0844 844 4744
Email: sales@advancedmachinery.co.uk



Advanced Machinery Services

Advanced Straight Line Edger

User Experience

- Profile: Solid wood panel producer
- Configuration: 2 advanced bottom rip saws in series
- Material: Pre-planed lumber on top and bottom surfaces
- Cutting dimensions: 100mm (W) x 60mm (H) x 600mm (L)
- Capacity: 2000 PCS/hour @ 20m/min (Excluding loading time)



Machining Procedure

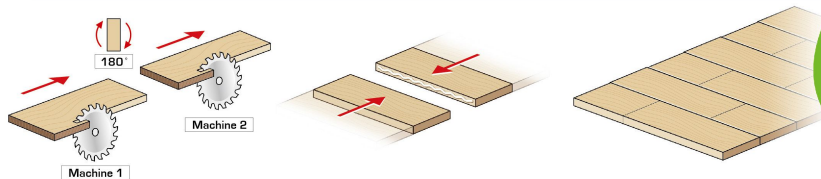

Sawing

Gluing

Assembly

CE Side Guard

Anti-kickback Fingers
(Bottom/Top) for Safer
Feeding Operations

Ruggedly Built
FC 28-30 Cast Steel
with Worm Gear System
for Elevation

Feeding Speed
Controlled by Inverter

CE Locking System
for Access Door to
the Saw Blade

Robust Machine Body
Designed with Welded
Steel Frame

Dual-purpose
Light Fence for
Ripping & Splitting

Automatic Lubrication
for Chain Conveyor

CE Electrical
Cabinet, incl.
Safety Relay,
Emergency
Stop and
Power Lock