

***INSTRUCTION MANUAL***  
***FOR***  
***AGSP***  
***TILTING ARBOR***  
***PANEL SAWBENCH***  
***(WITH SCORING SAW UNIT)***

BOOK NO. 8870

IMPORTANT

It is our policy and that of our suppliers to review constantly the design and capacity of our products. With this in mind we would remind our customers that whilst the dimensions and performance data contained herein are current at the time of going to press, it is possible that, due to the incorporation of latest developments to enhance performance, dimensions and supplies may vary from those illustrated.

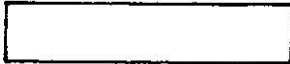

PLEASE INSERT SERIAL NUMBER OF MACHINE

## Instruction Manual For

# AGSP

## Tilting Arbor Panel Sawbench (With Scoring Saw Unit)

HEALTH & SAFETY SPECIFICATION	Page 2 & 3
STANDARD ITEMS DESPATCHED WITH MACHINE	Page 5
SLINGING	Page 6
FOUNDATION	Page 10
CLEANING	Page 7 & 10
WIRING DETAILS	Page 10
LUBRICATION	Page 8, 9, 10
INSTALLATION	Page 10 & 26
GUARD & RIVING KNIFE ADJUSTMENT	Page 12
START/STOP CONTROLS	Page 12
ISOLATOR SWITCH	Page 12
RISE & FALL CONTROLS	Page 12
CANTING CONTROLS	Page 14
RIP FENCE CONTROLS	Page 14
MITRE FENCE	Page 14
MOUNTING MAIN SAWBLADE	Page 16
MOUNTING SCORING SAWBLADE	Page 18
SCORING SAW	Page 18
SCORING SAW ALIGNMENT TO MAIN SAWBLADE	Page 21
BELT TENSION OR BELT CHANGING ON SCORING SAW	Page 21
BELT TENSION ON MOTOR	Page 23
SAFETY SECTION	Page 23
SAWBLADES	Page 25
BEARING & BELTS	Page 25
MACHINE PARTS LIST	Page 25
MAINTENANCE	Page 28 to 43
EXTRA EQUIPMENT	Page 44 to 47
	Page 48 to 50

FOR REPLACEMENT PARTS, TOOLS AND ACCESSORIES  
CONTACT: LEIC (0116) 276 9111

Bursgreen (Durham), Division of Wadkin PLC, Fence Houses, Houghton le Spring,  
Tyne & Wear, DH4 5RQ, England



## HEALTH & SAFETY

### SAFETY OF WOODWORKING MACHINES

Woodworking machines can be dangerous if improperly used. The wide range of work of which they are capable, requires adequate safeguarding arrangements against possible hazards.

Many injuries to machinists are caused by carelessness or failure to use the guards provided or to adjust them correctly.

WADKIN LTD., supply machinery designed for maximum safety which they believe, as a result of thorough testing, minimizes the risks inevitable in their use. It is the user's responsibility to see that the following rules are complied with to ensure safety at work:

1. The operation of the machine should conform to the requirements of the Woodworking Machines Regulations 1974. All guards should be used and adjusted correctly.
2. Safe methods of working only should be adopted as given in the Health and Safety Work Booklet No.41, "Safety in the Use of Woodworking Machines", (obtainable from Her Majesty's Stationery Office) and as advised by Wadkin Ltd.
3. Only personnel trained in the safe use of a machine should operate it.
4. Before making adjustments or clearing chips, etc., the machine should be stopped and all movement should have ceased.
5. All tools and cutters must be securely fixed and the speed selected must be appropriate for the tooling.

*SAFETY IS OUR WATCHWORD BUT THE USER MUST COMPLY WITH THE ABOVE RULES IN HIS OWN INTEREST. WE WOULD BE PLEASED TO ADVISE ON THE SAFE USE OF OUR PRODUCTS.*

# Safety

CAREFULLY READ INSTRUCTION MANUAL WITH PARTICULAR REFERENCE TO THE FOLLOWING INSTRUCTIONS:-

- 1) SLINGING, i.e. SAFE LIFTING LIMITS FOR SLINGS, ETC.
- 2) INSTALLATION AND FOUNDATION, i.e. SAFE WORKING AREA OF MACHINE AND BOLT POSITIONS, ETC.
- 3) WIRING DETAILS, i.e. WIRING DIAGRAM AND INSTRUCTIONS FOR SAFE WIRING OF MACHINE.
- 4) MACHINE CONTROLS AND OPERATING INSTRUCTIONS.
- 5) SELECT CORRECT SPEED FOR CUTTER EQUIPMENT AND ENSURE CUTTERS ARE SECURELY LOCKED IN POSITION.
- 6) SET GUARDS CORRECTLY TO COVER CUTTER EQUIPMENT AS MUCH AS POSSIBLE.
- 7) NOTE START/STOP CONTROL POSITION AND ISOLATOR SWITCH POSITION (IF FITTED) BEFORE OPERATING MACHINE.
- 8) USE FEEDING DEVICES WHERE POSSIBLE.
- 9) REFER TO HEALTH AND SAFETY AT WORK BOOKLET No.41 (IN UK) FOR SAFETY IN THE USE OF WOODWORKING MACHINERY.
- 10) DO NOT RUN LARGE SAWBLADES AT HIGH SPEED.

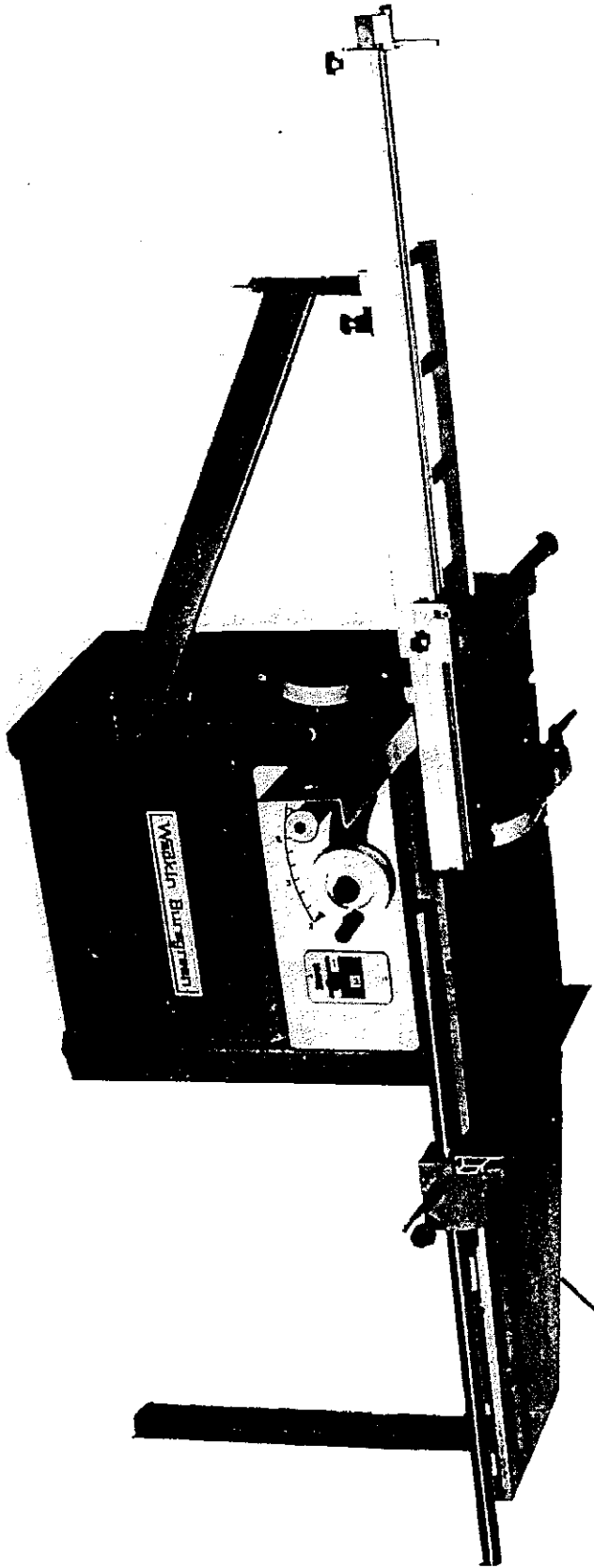

Extension table (Extra)

Tilting arbor panel Sawbench  
(with scoring saw unit)

FIG. 1

SPECIFICATION

Max. Dia. of Saw when Scoring	250mm	10 in
Max. Dia. of Saw when not scoring	300mm	12 in
Max. Saw Projection with 250mm Saw	75mm	3 in
Max. Saw Projection with 300mm Saw	100mm	4 in
Max. Thickness of Panel when not scoring	30mm	1 1/4 in
Max. Panel when Scoring	960 x 2500mm	38 x 98 in
Max. Panel when no Scoring	1000 x 2500mm	39 x 98 in
Max. Distance Saw to Stops on Sliding Table Crosscut Fence	2500mm	96 in
Max. Distance Saw to Rip Fence	916mm	36 in
Max. Distance Saw to Rip Fence with Extension Table	1250mm	49 in
Size of Main Table	815 x 711mm	32 x 28 in
Dia. of Saw Spindle	20mm	
Power of Motor - Standard	2.2kw	3 hp
- Optional	3.7kw	5 hp
Speed of Main Sawblade	3850rpm	
Dia. of Scorer Blade	105mm	
Speed of Scorer Blade	7000rpm	
Approximate Floor Space	2700 x 2700mm	106 x 106 in
Approximate Net Weight of Machine	265kg	585 lb
Approximate Gross Weight of Machine	305kg	680 lb
Shipping Dimensions - Machine	0.93 x 0.83 x 1.0 m	36 x 32 x 39 in
- Sliding Table	1.74 x 0.17 x 0.13m	68 x 7 x 5 in

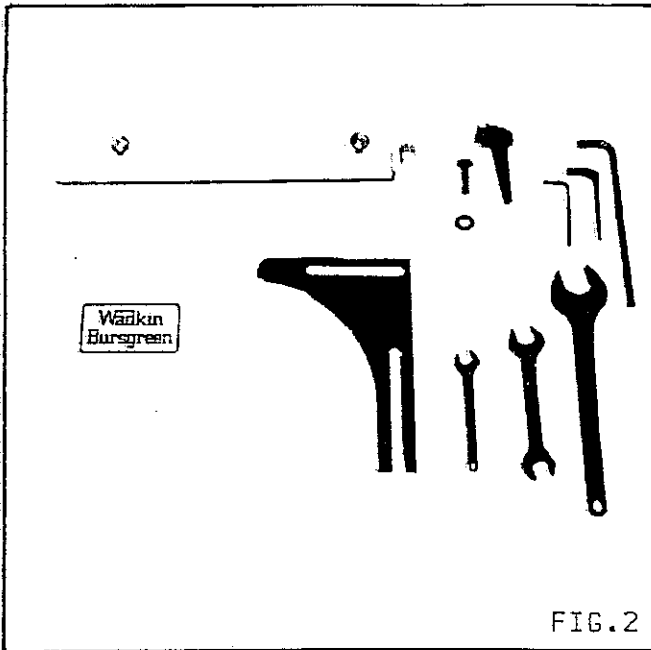

STANDARD ITEMS DESPATCHED WITH MACHINE

FIG. 2

- 1 - Instruction Manual
- 1 - Sawguard SP12/64 c/w Visor and Locking Handles
- 1 - 5mm Hexagon Wrench
- 1 - 6mm Hexagon Wrench
- 1 - 8mm Long Arm Hexagon Wrench
- 1 - 32 A/F Spanner
- 1 - 17/19 A/F Spanner
- 1 - 13 A/F Spanner

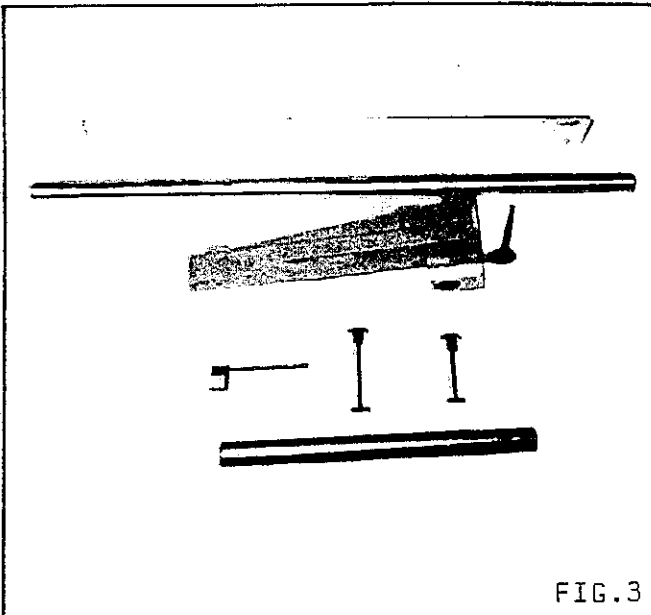

FIG. 3

- 1 - Rip Fence Plate
- 1 - Fence Bar
- 1 - Rip Fence Bracket
- 2 - Rip Fence Plate Locking bolt c/w Plastic Handwheels
- 1 - Rip Fence Pointer
- 1 - Rip Fence Support Bar

EXPORT ONLY

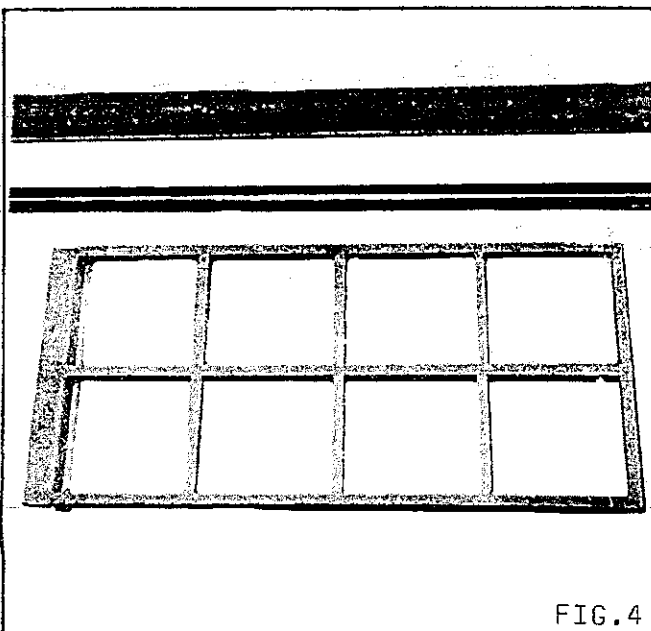
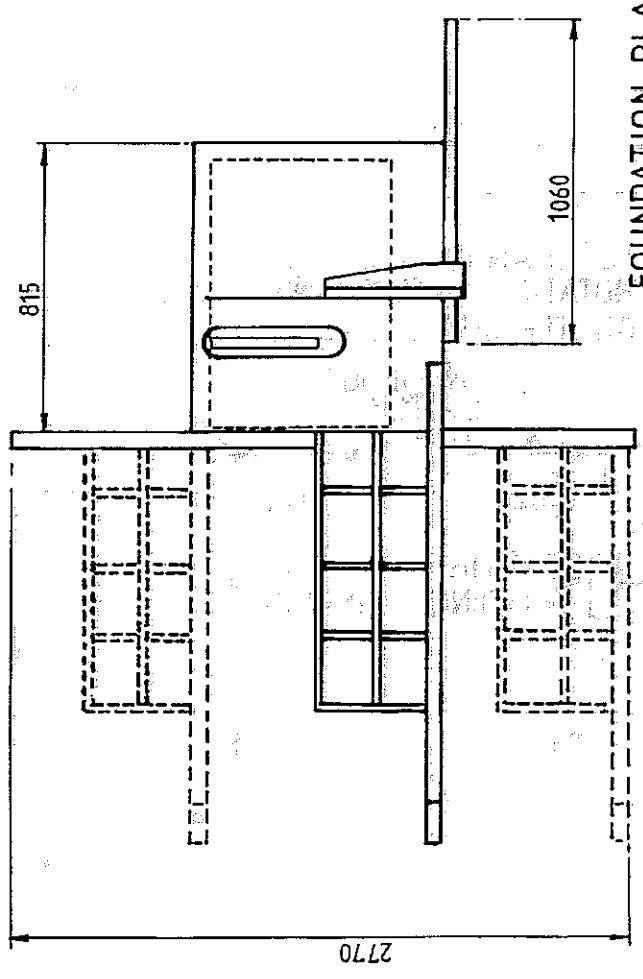
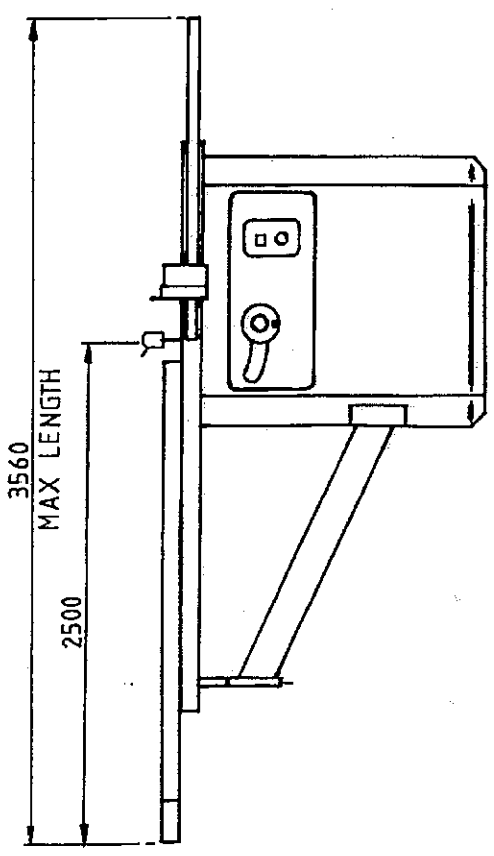
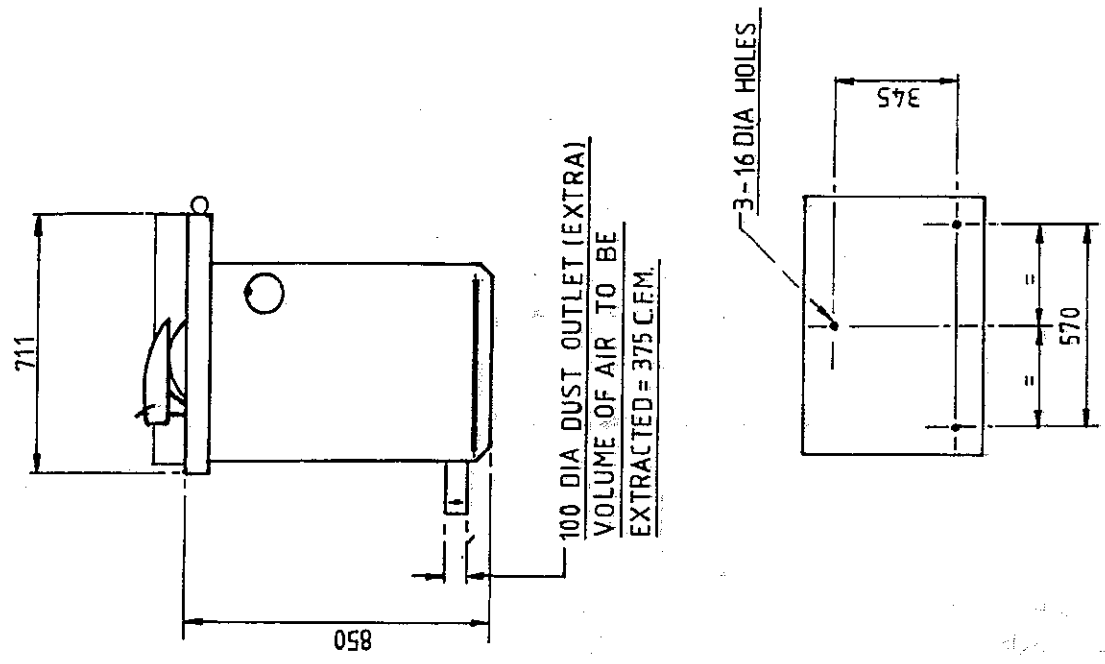

FIG. 4

- 1 - Crosscut Fence c/w Turn-over stops
- 1 - Slide Bar
- 1 - Sliding Table

FIG. 4



FOUNDATION PLAN FOR AGSP



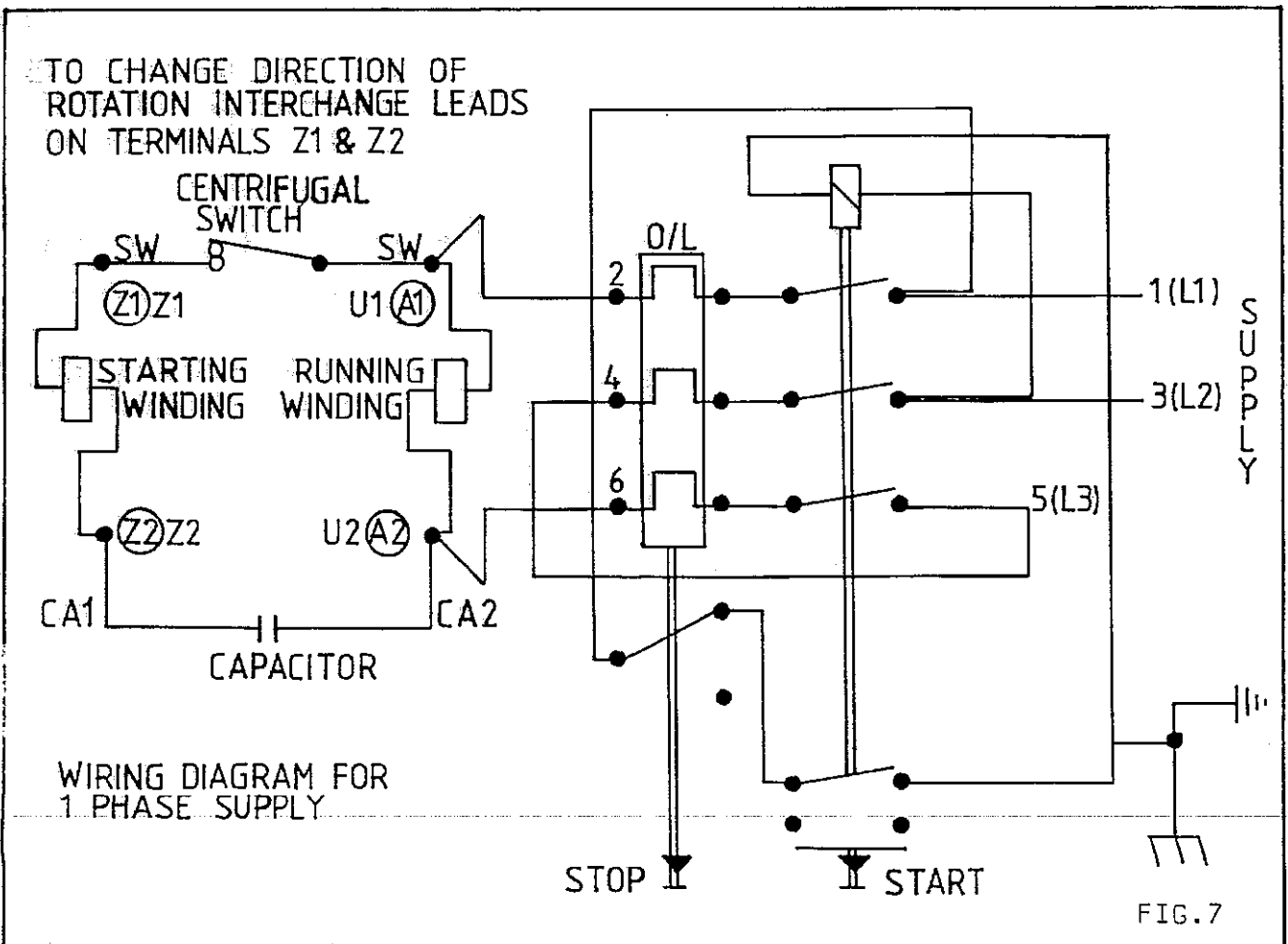
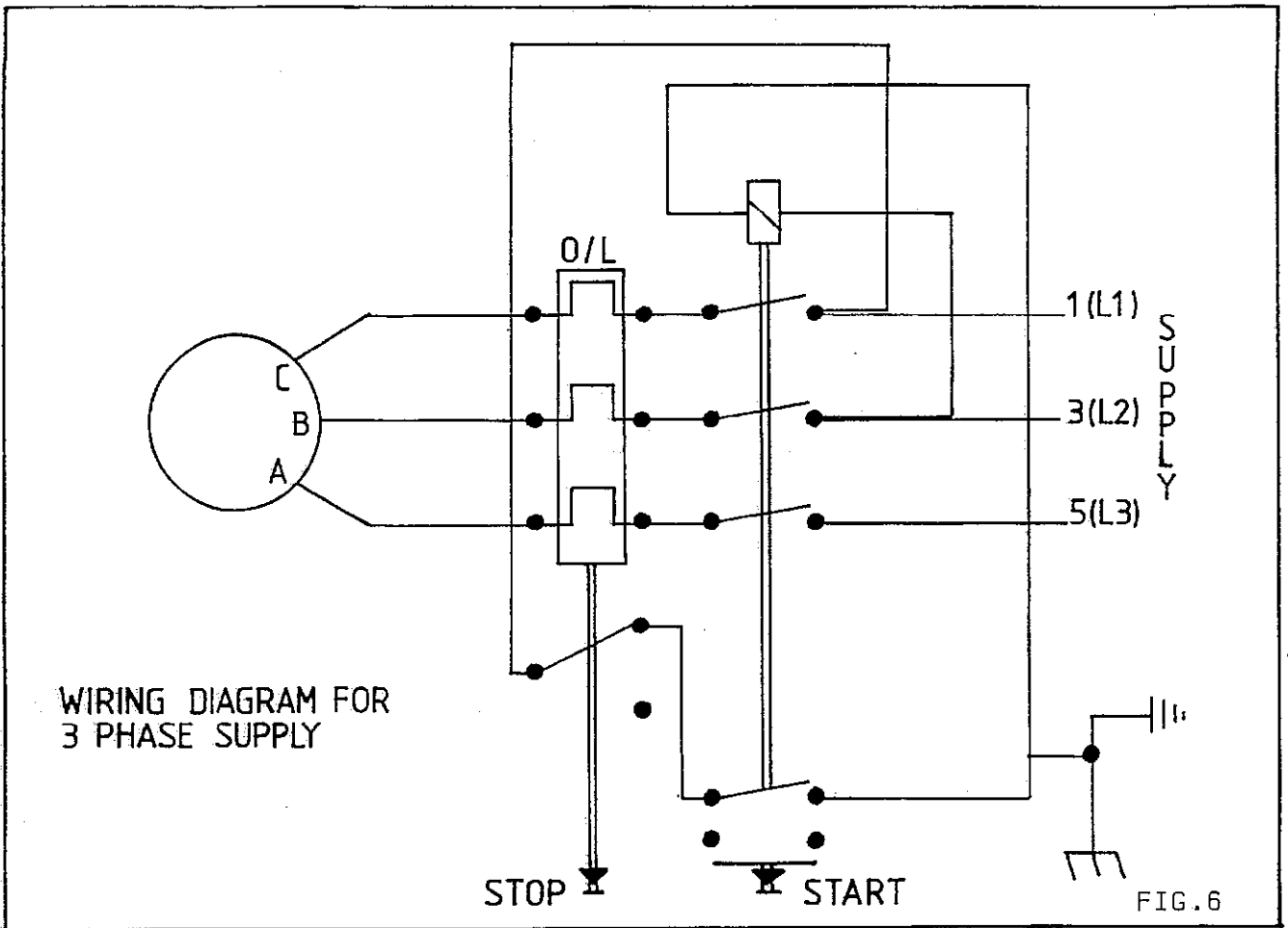
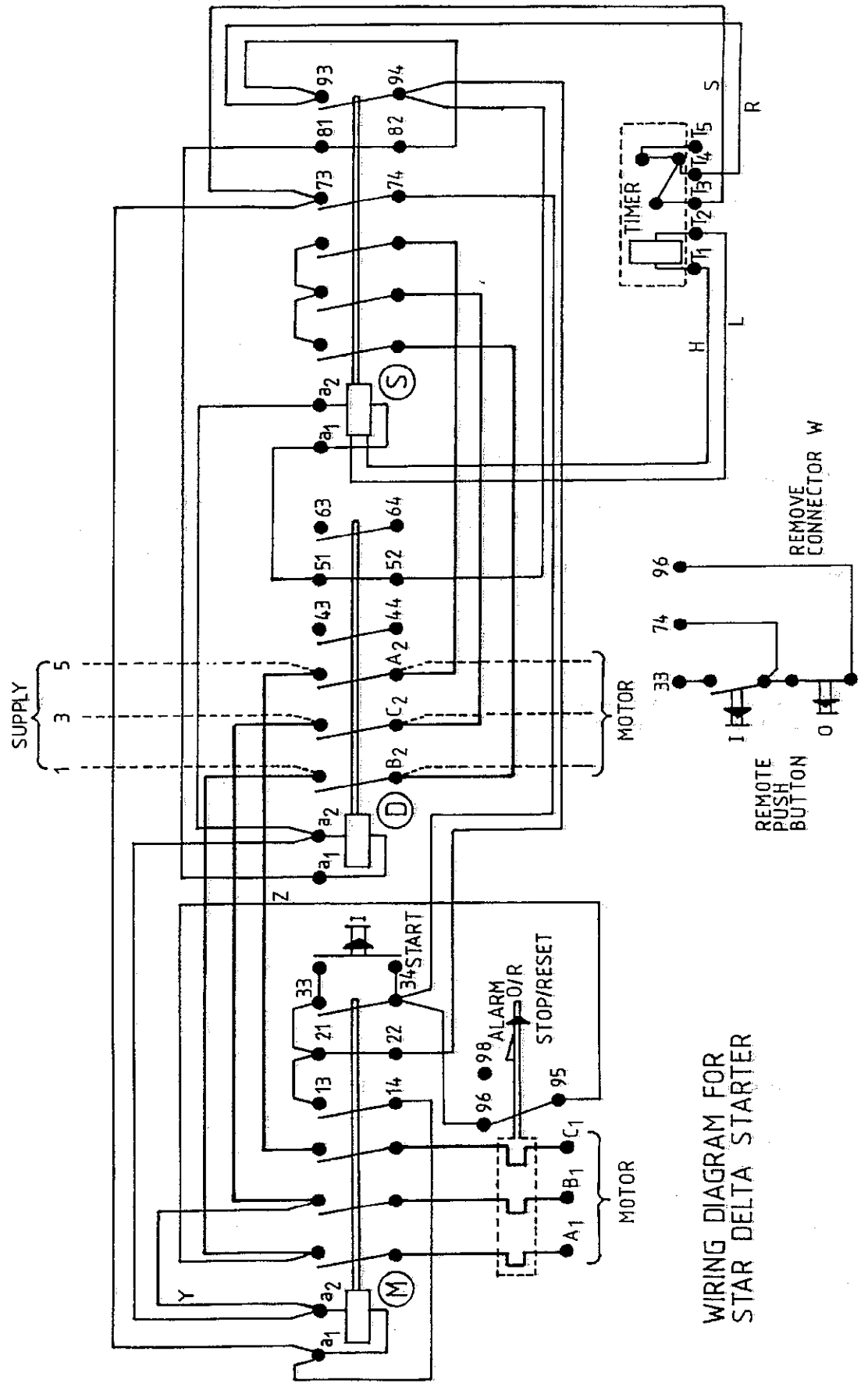

FIG. 8



WIRING DIAGRAM FOR STAR DELTA STARTER

REMOVE PUSH BUTTON  
CONNECTOR W

SLINGING

Always use a sling within safe working load of machine weight.

Approximate net weight of machine - 265 kg  
 Approximate gross weight of machine - 305 kg

Attach slings to machine as shown in FIG.9, ensuring damage will not be caused to machine during slinging operation.

IMPORTANT: DO NOT WALK OR STAND UNDER MACHINE DURING SLINGING OPERATION.

CLEANING

Clean protective coating from all bright parts by applying a cloth soaked in paraffin, turpentine or other solvent.

FOUNDATION

Ensure floor is level, mark floor to suit 3 - M12 rawlbolts, refer to foundation plan FIG.5. Drill floor to suit rawlbolts. These bolts are not supplied with machine, but can be supplied at an additional charge. To obtain access to foundation bolts and stabilizing bolts, open front access door using 8mm allen key (turn clockwise to loosen). Release 2 stabilizing bolts 'A' FIG.10, bolt machine to floor, jack bolts 'A' until they touch the floor, lock in position with locknuts, close front access door.

WIRING DETAILS

The motor and control gear have been wired in before despatch. All that is required is to connect the power supply to starter or isolator when fitted.

Points to note when connecting power supply:-

- 1) Check the voltage, phase and frequency, correspond to those on the motor plate, also the correct coils and heaters are fitted to the starter.
- 2) It is important that the correct cable is used to give the correct voltage to the starter as running on low voltage will damage the motor.
- 3) Check the main line fuses are correct capacity. See fuse list inside starter cover.
- 4) Connect the line leads to the appropriate terminals. See wiring diagrams FIG.6, FIG.7 and FIG.8.
- 5) Check all connections are sound.
- 6) Check the rotation of the motor for the correct direction if this is incorrect, reverse any two of the line lead connections.

LUBRICATION

All bearings are sealed for life and require no lubrication. Oil Rise/Fall screw, canting screw and slides - once weekly

Approved lubricants, see page 26.

~~It is advisable to keep all bright parts covered with a thin film of oil to prevent rusting.~~

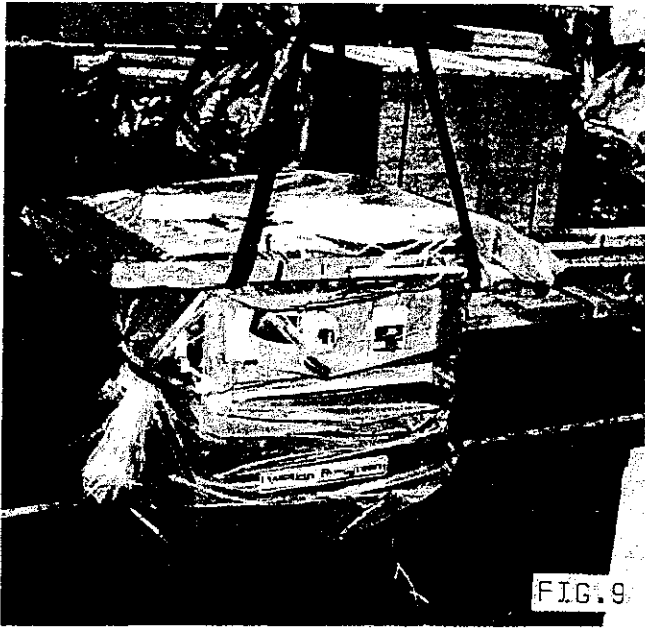

FIG. 9

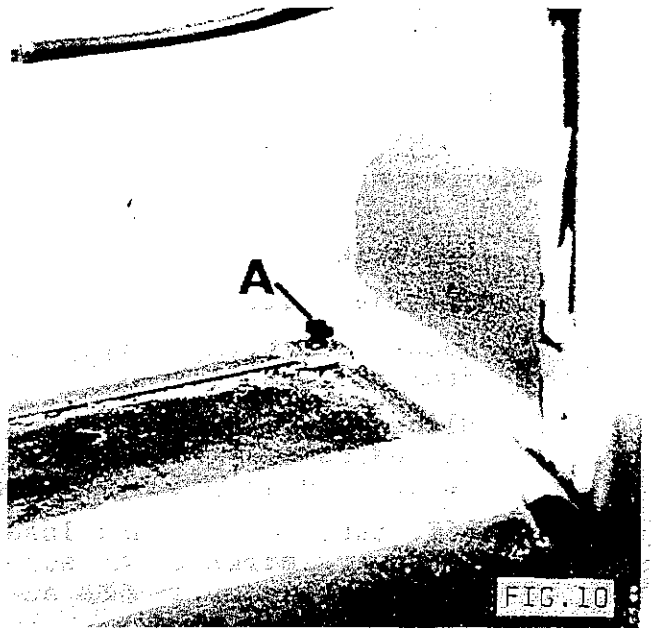

FIG. 10

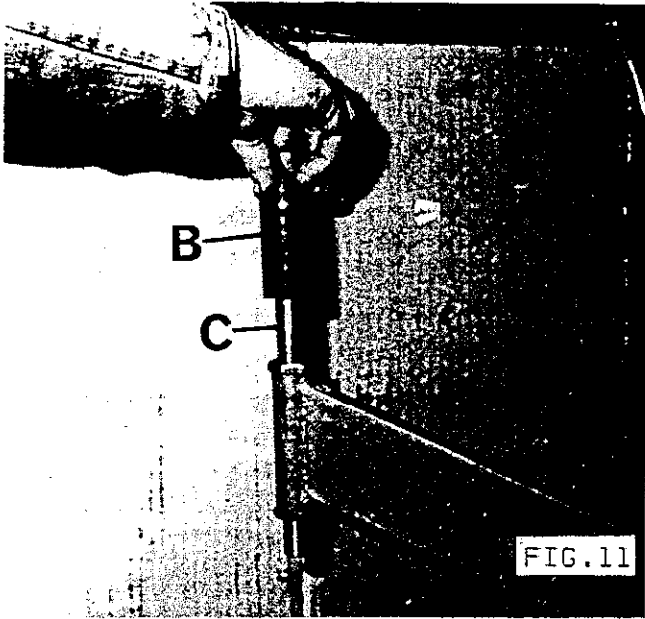

FIG. 11

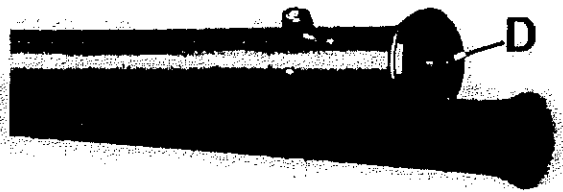

FIG. 12

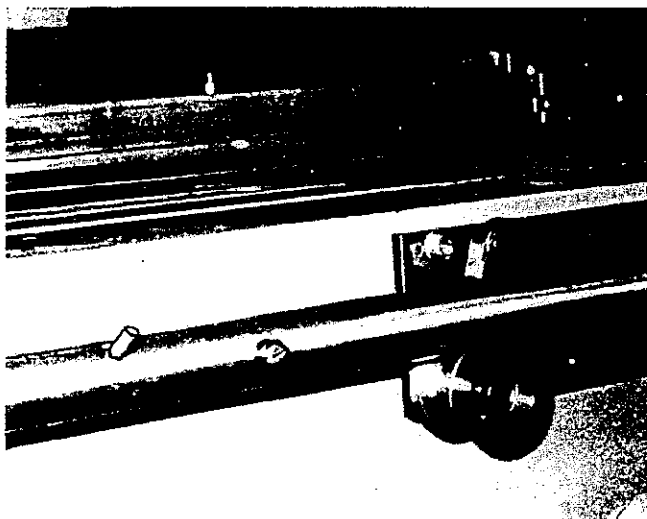

FIG. 13

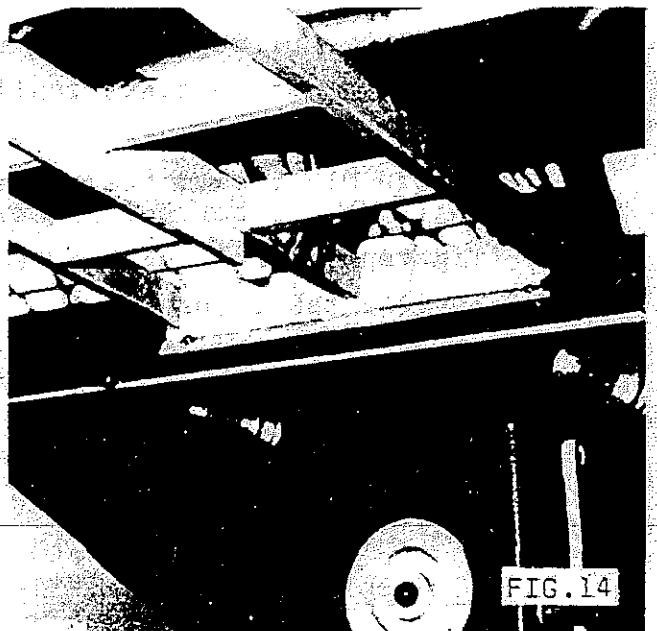

FIG. 14

## INSTALLATION

Machines for home market, the sliding table and crosscut fence, when fitted, are removed for the ease of transportation.

Machine for export market, the sliding table, crosscut fence when fitted and rip fence are removed.

To re-assemble sliding table, proceed as follows:-

- 1) Position plastic support 'B' FIG.11, on swinging arm pin 'C'.
- 2) Loosen M10 hexagon head bolts and remove end stop 'O' FIG.12 from slide bar.
- 3) Slide bar through rollers FIG.13, with the 2 studs pointing up and out away from table. When slide bar is in position, secure end stop to slide bar FIG.12.
- 4) Lift table FIG.14 and locate table on the 2 slide bar studs. Locate nylatron outer support on under table web as shown.FIG.15 Secure table by 2 - M8 aerotight nuts.
- 5) Secure the 2 fence location support blocks to edge of sliding table.FIG.16, then position fence on blocks as shown and secure by locking knobs.
- 6) Locate guard onto front of table slide bar with M10 hexagon nut in end of bar and M8 hexagon nut in side of bar.

To re-assemble rip fence, proceed as follows and refer to FIG.19:-

Locate studs 'M' into the holes in the front of main table. Set fence bar parallel to table top and lock in position with nuts provided.

NOTE: DO NOT DISTURB LOCKNUTS AS THESE ARE SET IN FACTORY TO GIVE CORRECT FENCE ALIGNMENT.

Assemble fence and lock stop screw in end of fence bar. Fit fence support 'N' to table edge and ensure support is set level to table top.

## GUARD AND RIVING KNIFE ADJUSTMENT

The riving knife and guard rise and fall with the saw. The riving knife should be adjusted to the closest practical distance from the saw teeth.

To adjust the riving knife to this position, proceed as follows:-

- 1) Isolate machine electrically.
- 2) Remove table insert.
- 3) Loosen M16 socket head screw 'A' FIG.17, and move riving knife 'B' to correct position.
- 4) Tighten securely socket head screw 'A'.
- 5) Replace table insert.

The sawguard should then be adjusted to cover as much of the saw as possible.

## START/STOP CONTROLS

The start/stop buttons 'C' FIG.18 are conveniently situated on front of machine.

## ISOLATOR SWITCH (OPTIONAL EXTRA)

A lockable isolator switch can be fitted to the right hand side of the start/stop controls.

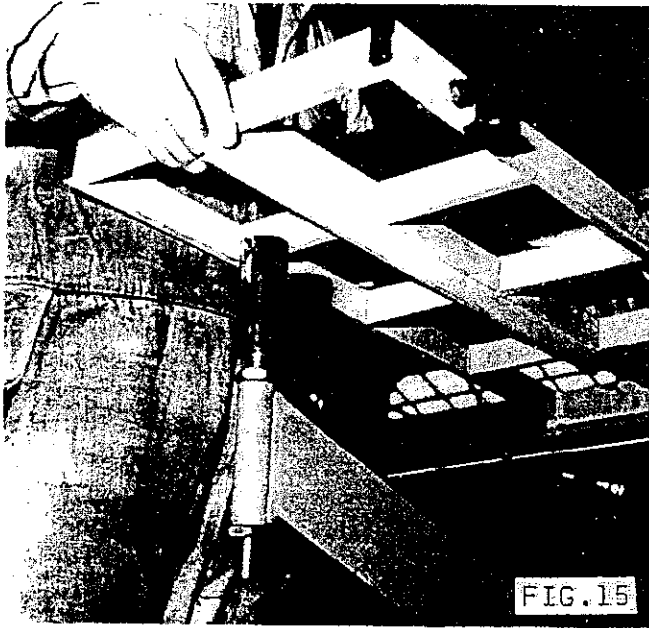

FIG. 15



FIG. 16

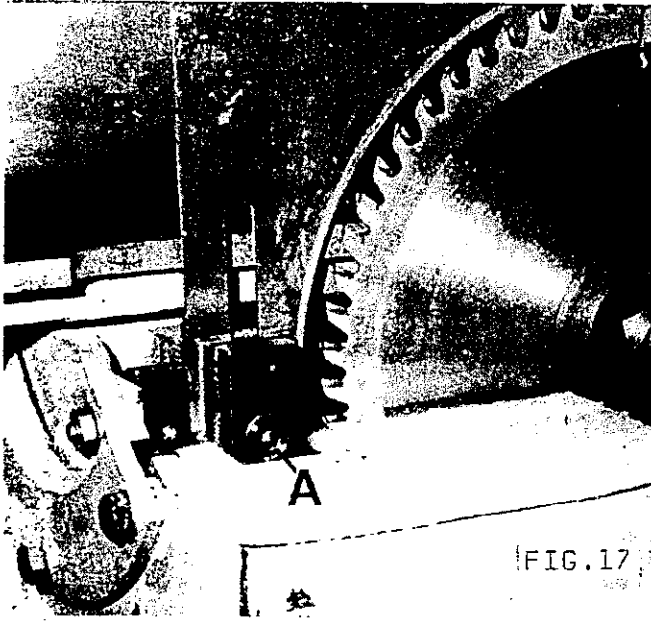

FIG. 17

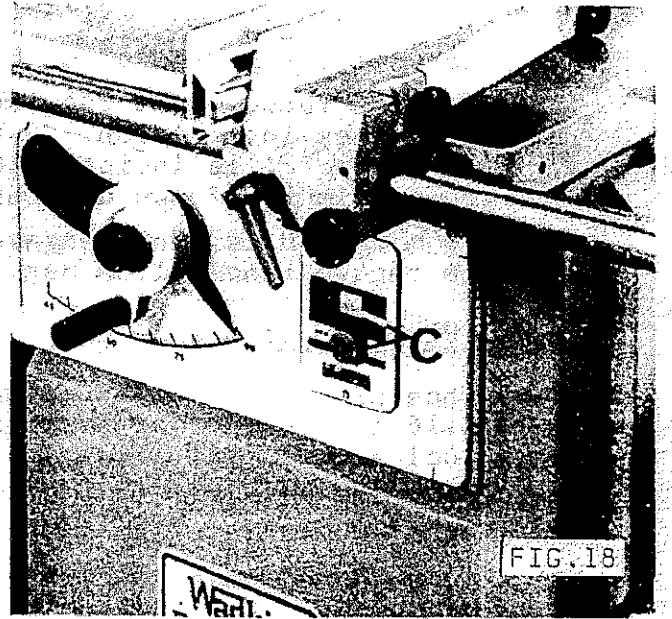

FIG. 18

### RISE AND FALL CONTROLS

For rise and fall of saw arbor, proceed as follows:-

Release locking handle 'A' in FIG.19 and raise or lower the saw arbor by the handwheel 'B' to the required position then relock handle 'A'.

### CANTING CONTROLS

The saw cants 45° to the right with positive stops at 90° and 45°. For canting of saw arbor, proceed as follows:-

Release locking handle 'C' in FIG.19 and turn handwheel 'D' working in conjunction with the canting scale indicated by the pointer to the required saw position. Relock handle 'C'.

### RIP FENCE CONTROLS

The rip fence slides on a round bar fitted to front of table. Rapid fence adjustment and micro-adjustment are provided with an effective lock.

For rapid fence adjustment, proceed as follows:-

- 1) Loosen locking handle 'E' FIG.19.
- 2) Position fence where required then turn locking handle 'E' to lock fence in position. A ripping capacity scale on fence slide bar 'F' is indicated by an adjustable pointer 'G' located in the fence body and secured by grub screw 'H'.
- 3) For micro-adjustment, engage spring loaded handwheel 'J' in the racked fence slide bar.

### Fence Plate Positions

The fence plate 'K' in FIG.19 has two positions. Position shown in FIG.18 is for use with deep stock, fence can be moved longitudinally to facilitate this. Position shown in FIG.19 is for use with faced panels, melamine, veneer, etc.

To change the fence plate position, proceed as follows:-

- 1) Loosen handwheels 'L' in FIG.19 then slide fence plate from fence body.
- 2) Slide fence plate over the two locking plates to position shown in FIG.20, then relock handwheels 'L'.

### Fence Pointer Adjustment

When the fence plate position has been changed as previously described, the pointer 'G' in FIG.19 must be reset accordingly.

To reset pointer, proceed as follows:-

- 1) Loosen locking handle 'E' FIG.19, then move fence to a position which would allow a reasonable cut to be taken. Turn locking handle 'E' to lock fence in position.
- 2) Start machine, then feed a piece of timber past the sawblade keeping timber firmly against the fence. Stop machine.
- 3) Accurately measure the width of timber, then loosen grub screw 'H' and set pointer 'G' accordingly. Relock grub screw 'H'.

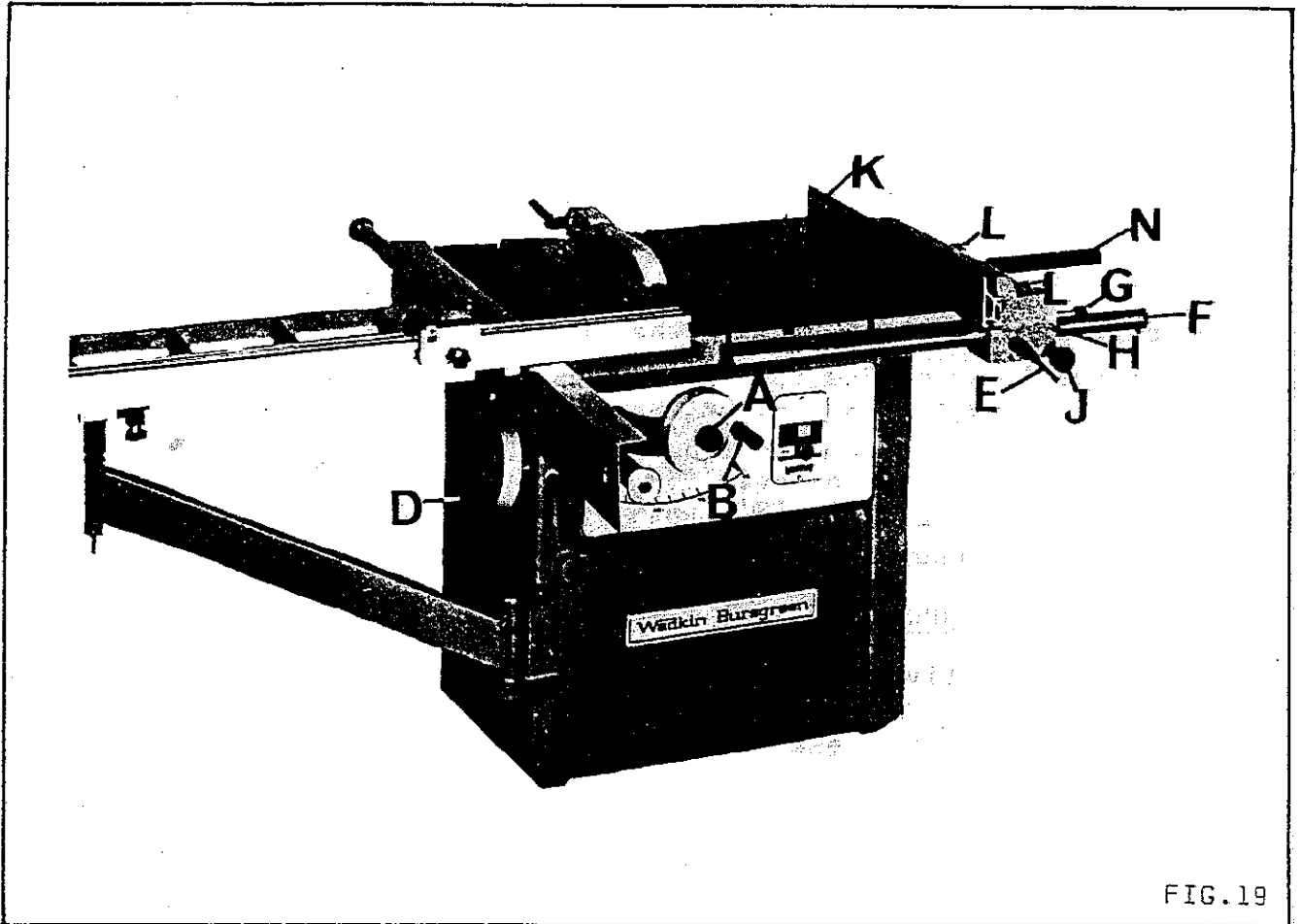

FIG.19

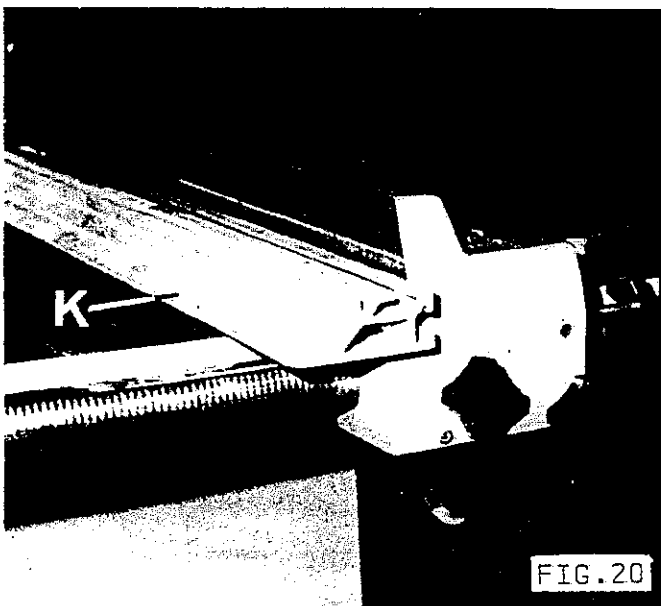

FIG.20



## MITRE FENCE

The mitre fence 'A' in FIG.21 slides in either of two table slots and can be used at either side of the sawblade. Two stop rods 'B' are held together by two clamps and wingnuts 'C'. The stop rods are secured to the fence body by either of the two thumbscrews 'D' depending on which side of fence body the rods are used.

NOTE: Always ensure the stop rods are set clear of the sawblade or serious damage will result when machine is operated.

The mitre fence can be rotated through 90 degrees with positive stops at 90 degrees and 45 degrees.

To position mitre fence at required angle, loosen handwheel 'E' in FIG.21, then pull plunger 'F' from location, position fence as required using scale 'C', then relock handwheel 'E'

NOTE: Always ensure table slot is clean when using mitre fence.

## USE OF MITRE FENCE STOP RODS

Accurate repetitive cutting can be made using the stop rods, see FIG.22.

The rods are held in the fence by thumbscrews 'C' in FIG.21 and the stop rods held together by the two clamps 'H'. To adjust the rods by the clamps, loosen the wingnuts 'D'. See FIG.22 for several positions in which the stop rods can be used.

NOTE: Take care that the stop rods are always clear of the saw or serious damage will result.

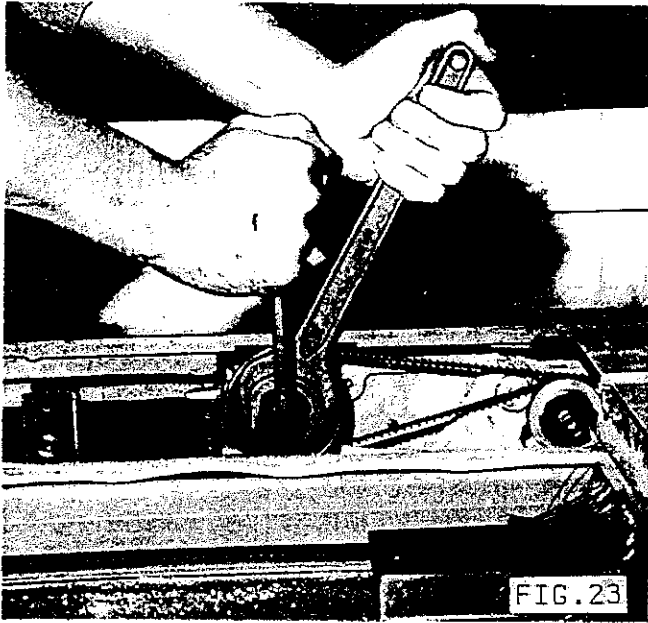

FIG. 23



FIG. 24

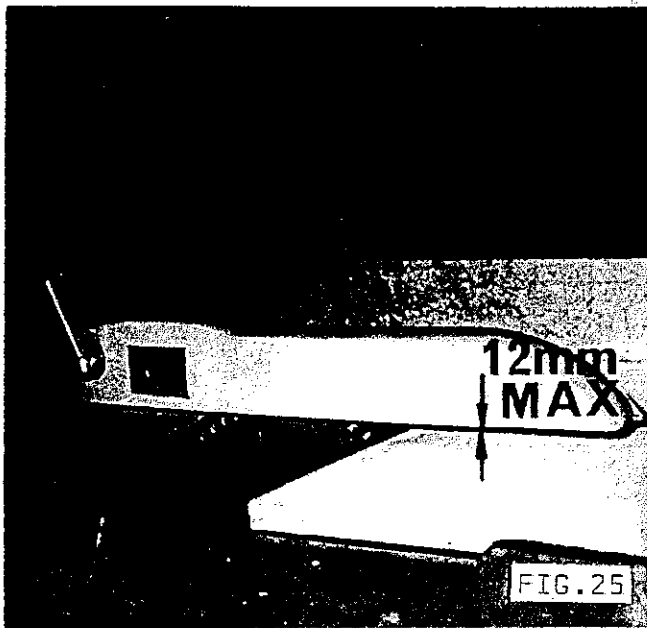

FIG. 25

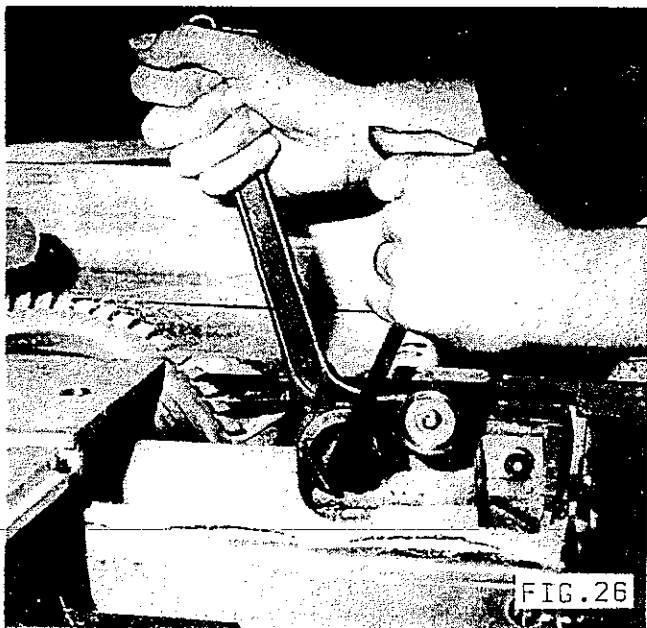
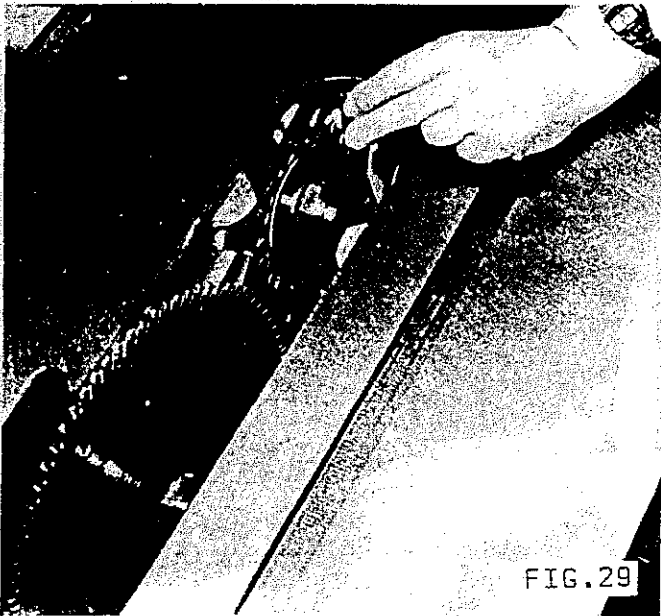
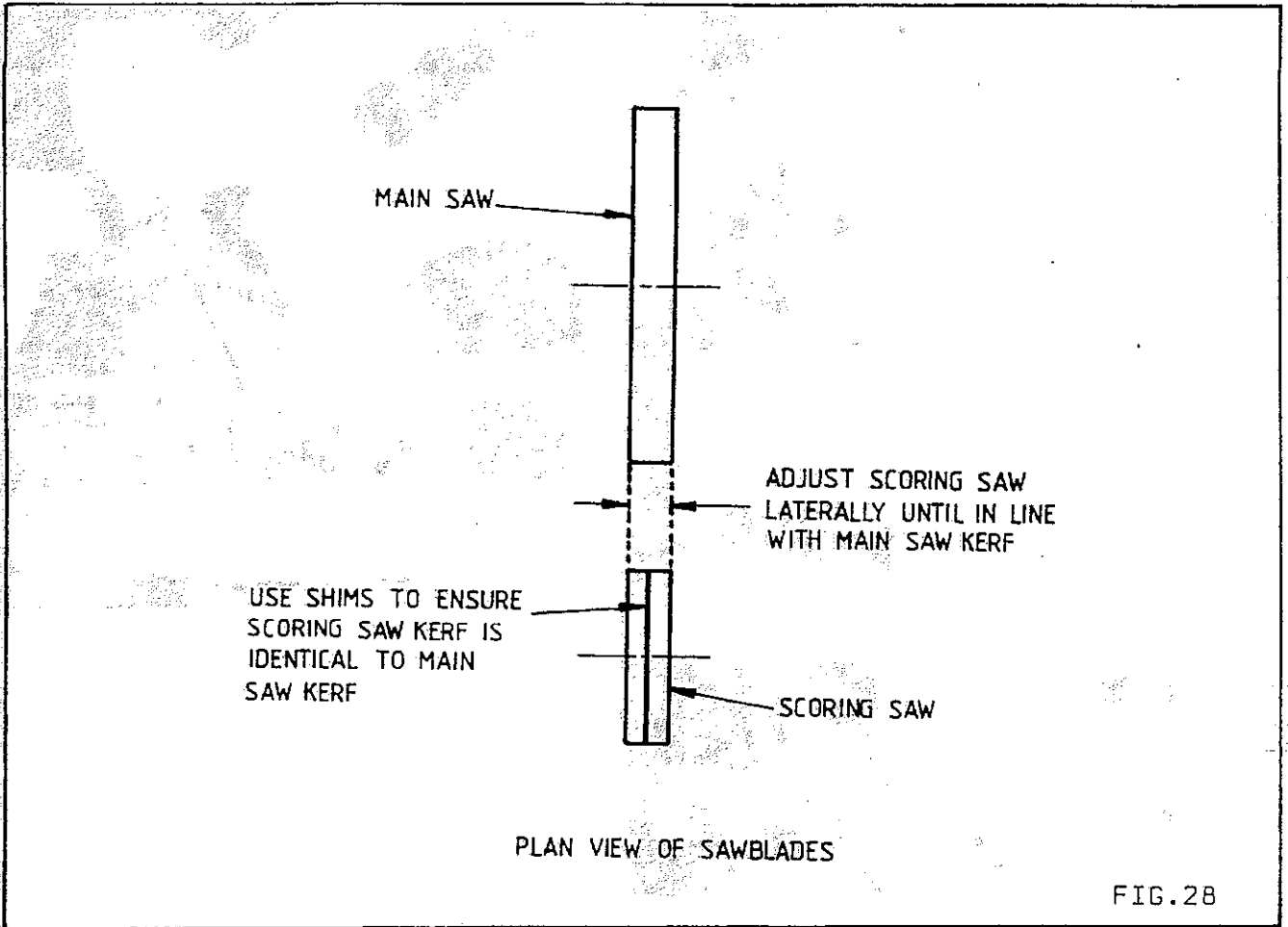

FIG. 26



FIG. 27



### SCORING SAW

Is designed to prevent splashing of all materials including plywood, fibreboard, chipboard, thicker solid plastics and materials having two face layers of veneer, etc.

A twin blade scoring saw must be used and is supplied with 3 shims of 0.010", 0.005" and 0.003" thick. These shims can be positioned between the blades as required to ensure the scoring saw kerf is identical to, or wider than, the main saw kerf.

Scoring saw lateral and vertical adjustments are provided to ensure accurate alignment to thickness of main sawblade, so that brittle materials can be cut with perfect finish on upper and lower edges at both sides of cut.

NOTE: SET SCORING SAW VERTICALLY TO ALLOW A MINIMUM SCORE IN MATERIAL TO BE CUT.

### SCORING SAW ALIGNMENT TO MAIN SAWBLADE

- 1) Place a steel rule or similar straight edge across main blade and scoring blade to check approximate lateral alignment.
- 2) Lateral adjustment to scoring saw blade is by locating 6mm allen key (supplied) in scoring saw spindle as shown in FIG.29 and laterally adjust sawblade by turning allen key in a clockwise or anticlockwise direction.
- 3) Vertical adjustment of scoring sawblade is automatically compensated by raising or lowering the main sawblade.

NOTE: MAXIMUM THICKNESS OF TIMBER WHEN SCORING = 30mm.

- 4) Proceed to take trial cuts to establish the accuracy of the alignment of the scoring saw blade with the main blade. The correct alignment is shown in FIG.28.

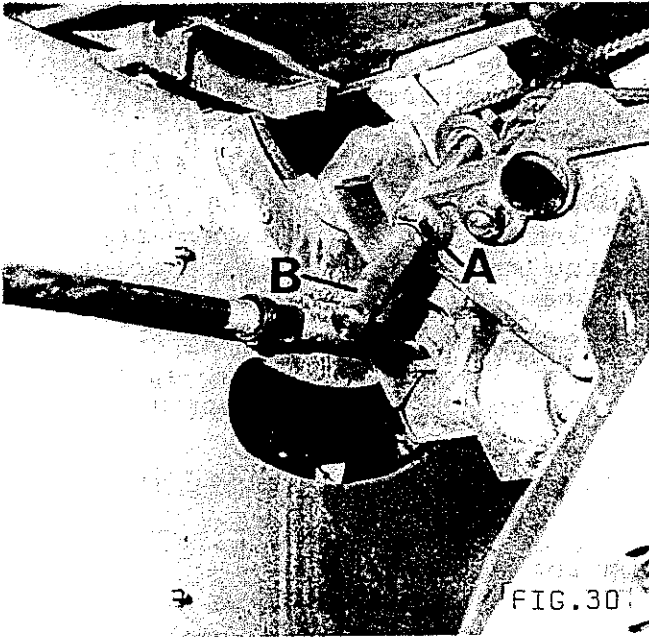

FIG. 30

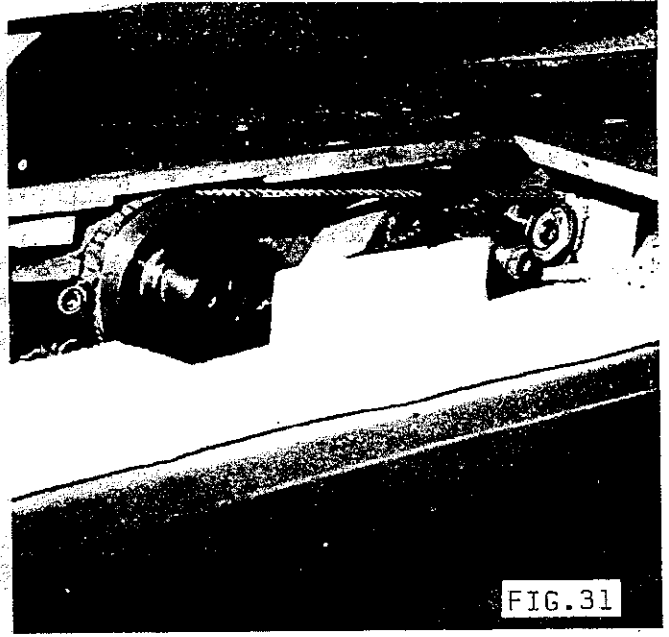

FIG. 31

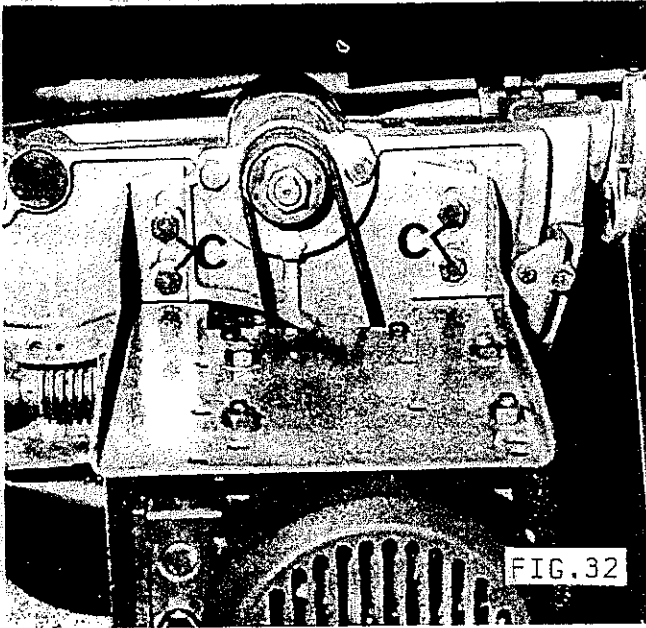

FIG. 32

### BELT TENSION OR BELT CHANGING ON SCORING SAW

The scoring saw is driven by a 'Poly-Vee' belt from the main saw spindle.

To tension or change belt, proceed as follows:-

- 1) Isolate machine electrically.
- 2) Remove table insert.
- 3) Remove both saws as previously described, page 18.
- 4) Cant saw arbor to 45° as previously described, page 14.
- 5) Remove door.
- 6) Release belt tension from inside of machine by loosening locknut 'A' with spanner (supplied) FIG.30 and turning handle 'B' clockwise.
- 7) Remove belt from scoring saw tension pulley and then from main saw flange.

To fit new belt, proceed as follows:-

NOTE: REVERSE BELT SO GROOVES ARE ON OUTSIDE.

- 8) Replace belt over main saw flange as shown in FIGS.31 & 33.
- 9) Place belt over the top of scoring pulley and round tension pulley as shown in FIGS.31 & 33.
- 10) Re-tension belt from inside of machine by turning handle 'B' anti-clockwise until freeplay has been taken out of belt. Turn handle a further 1/16 of a turn to obtain correct tension, belt should feel reasonably tight. Relock locknut 'A' with spanner while holding handle 'B'.

### BELT TENSION ON MOTOR

The saw spindle is driven by a 'Poly-Vee' belt from a 2.2kw or 4kw motor giving a speed of 3850rpm.

To tension or change the belt, proceed as follows:-

- 1) Isolate machine electrically.
- 2) Remove door.
- 3) Loosen the 4 - M10 hexagon head bolts 'C' FIG.32.
- 4) Move motor platform until belt is tensioned.
- 5) Relock hexagon head bolts.
- 6) Replace door.

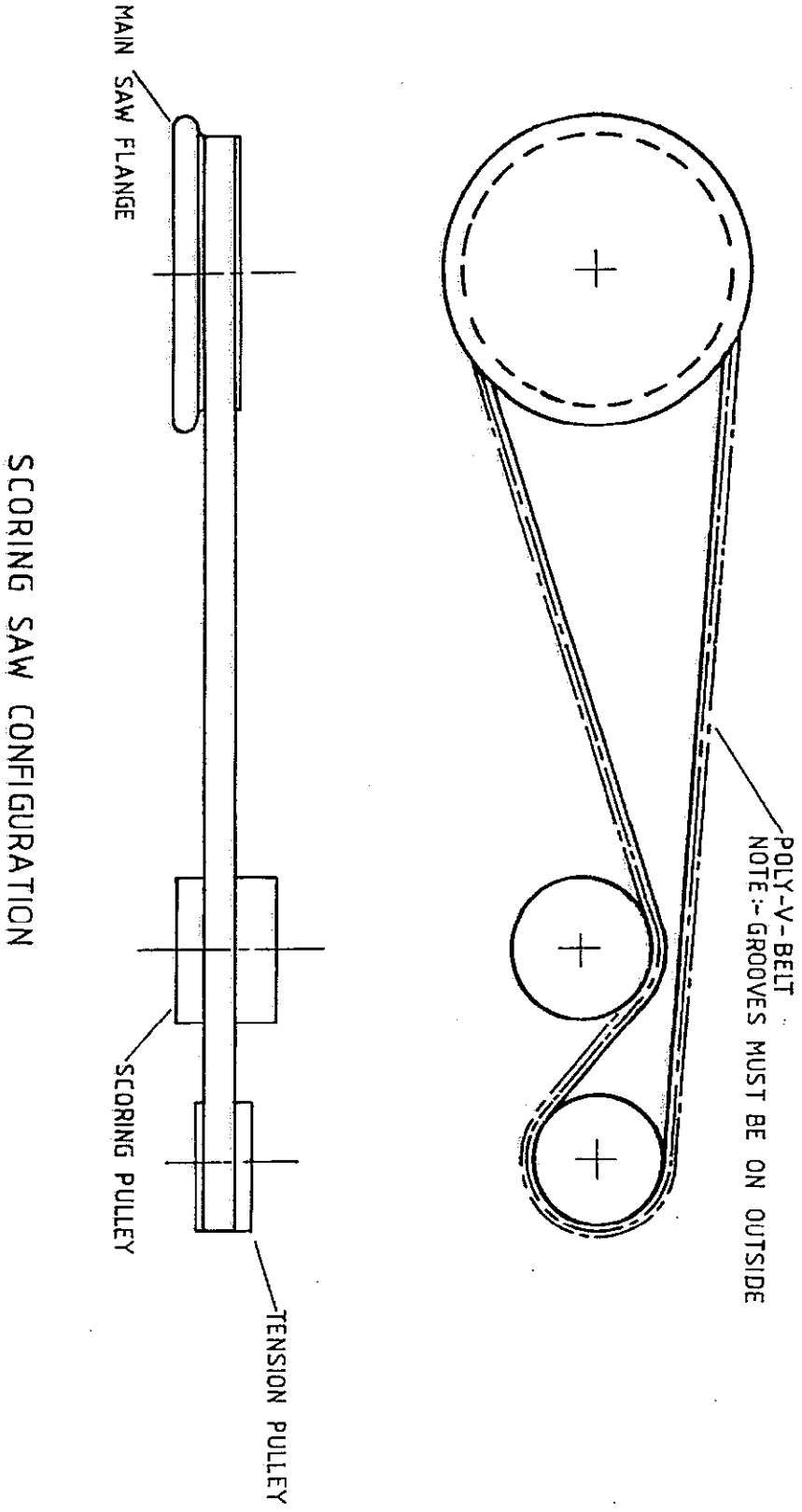

SCORING SAW CONFIGURATION

FIG.33

## SAFETY SECTION

All safety precautions should be taken to comply with relevant safety regulations, i.e. Woodworking Machine Safety Regulations 1974 No. 903 (Great Britain). Always adjust the riving knife and guard to protect as much of the saw as is possible. The adjustments have been previously described.

Do not use sawblades at higher than recommended speed. When changing sawblades, belts or any other maintenance etc., always isolate the machine electrically. Use a wood push stick as much as practicable when feeding timber, to avoid accidents.

## SAWBLADES

For best results, we recommend the purchase of sawblades from Bursgreen (Durham).

Sawblades available for scoring (kerf to be 3.2mm).

250mm diameter x 20mm bore TCT sawblade B-S-337

105mm diameter x 20mm bore TCT split scoring sawblade B-S-247

Other sawblades available:-

305mm diameter x 20mm bore alloy rip sawblade B-S-281

305mm diameter x 20mm bore alloy crosscut sawblade B-S-284

254mm diameter x 20mm bore alloy rip sawblade B-S-278

254mm diameter x 20mm bore alloy crosscut sawblade B-S-276

254mm diameter x 20mm bore TCT sawblade for ripping B-S-293

NOTE: 254mm DIAMETER MAXIMUM SAWBLADE WHEN SCORING IS REQUIRED

305mm diameter x 20mm bore TCT sawblade for ripping B-S-345

(FOR USE ONLY WHEN 3.7KW (5HP) MOTOR IS FITTED)

## BEARINGS

2 - 6203-2RS - Saw Spindle

2 - 6002-2RS - Scoring Saw

1 - 6001-2RS - Scoring Saw Tension Pulley

1 - SLFL 16 Flange Bearing Unit - Canting mechanism

1 - 51104 Thrust Race - Rise and Fall

## BELTS

1 - 220-J8 Poly 'V' Belt - Saw Drive

1 - 260-J4 Poly 'V' Belt - Scoring Saw Drive



A P P R O V E D L U B R I C A N T S

Application	Castrol	B.P.	Shell	Esso	Texaco/Caltex	Wadkin
Worm Boxes	ZN220	Energol CS320	Vitrexa 320	Spartan EP220	Regal Oil 320	L2
General Lubrication	Magna 68	Energol HP68	Vitrexa 68	Nurray	Ursa Oil P68	L4
Pneumatic Lubricators	Hyspin AWS32	Energol HL32	Tellus 37	Nuto H32	Rando Oil HD32	
Grease	Sphereol AP3	Energol L53	Alvania R3	Bacon 3	Regal Starfalk Premium 3	L6
Brake Cables	Brake Cable grease	Energol L21M	Alvania R3	Esso Multi-purpose grease		

# MACHINE PARTS LIST

## INDEX

Base Assembly	Page 28 to 29
Rise and Fall and Trunnion Assembly	Page 30 to 31
Saw Drive Motor Assembly	Page 32 to 33
Main Saw Spindle Assembly	Page 34 to 35
Scoring Saw Assembly	Page 34 to 35
Riving Knife and Sawguard Assembly	Page 36 to 37
Rip Fence Assembly	Page 38 to 39
Sliding Table Assembly	Page 40 to 41
Crosscut Fence Assembly	Page 42 to 43

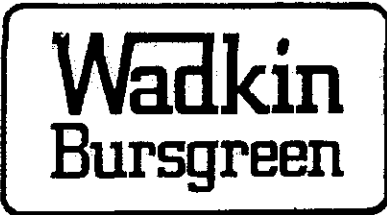

# ILLUSTRATED PARTS LIST

ASSEMBLY:- BASE			
FIG ITEM	PART NO. *	UNITS PER ASSEMBLY	DESCRIPTION
1	S25-666	1	Main Table
2	S25-667	1	Finger Plate
3	S25-601	1	Side Door for Base
4	S25-598	1	Base
5	C-S-348	1	Nameplate
6	S25-599	1	Control Plate
7	K51-16-155	1	MEM 647 ADS/F Starter 415-3-50 2.2kw
	K51-16-154	1	MEM 637 ADS/F Starter 380-3-50 2.2kw
	K51-16-156	1	MEM 817 ADS/F Starter 220-3-50 2.2kw
	K51-16-158	1	MEM 847 ADS/F Starter 415-3-50 4kw
	K51-16-160	1	MEM 1237 ADS/F Starter 380-3-50 4kw
	K51-16-161	1	MEM 1627 ADS/F Starter 220-3-50 4kw
8	BEL-51	1	Corner Moulding
9	BEL-52	1	Cap for Corner Moulding
10	S25-646	1	Extrusion for Nameplate
11	S25-675	1	Extrusion for Nameplate
12	S25-674	1	Extrusion for Nameplate
13	SP12-155	1	Extrusion for Nameplate

- ITEM NOT ILLUSTRATED

\* PLEASE QUOTE PART & MACHINE  
NUMBER WHEN ORDERING SPARES

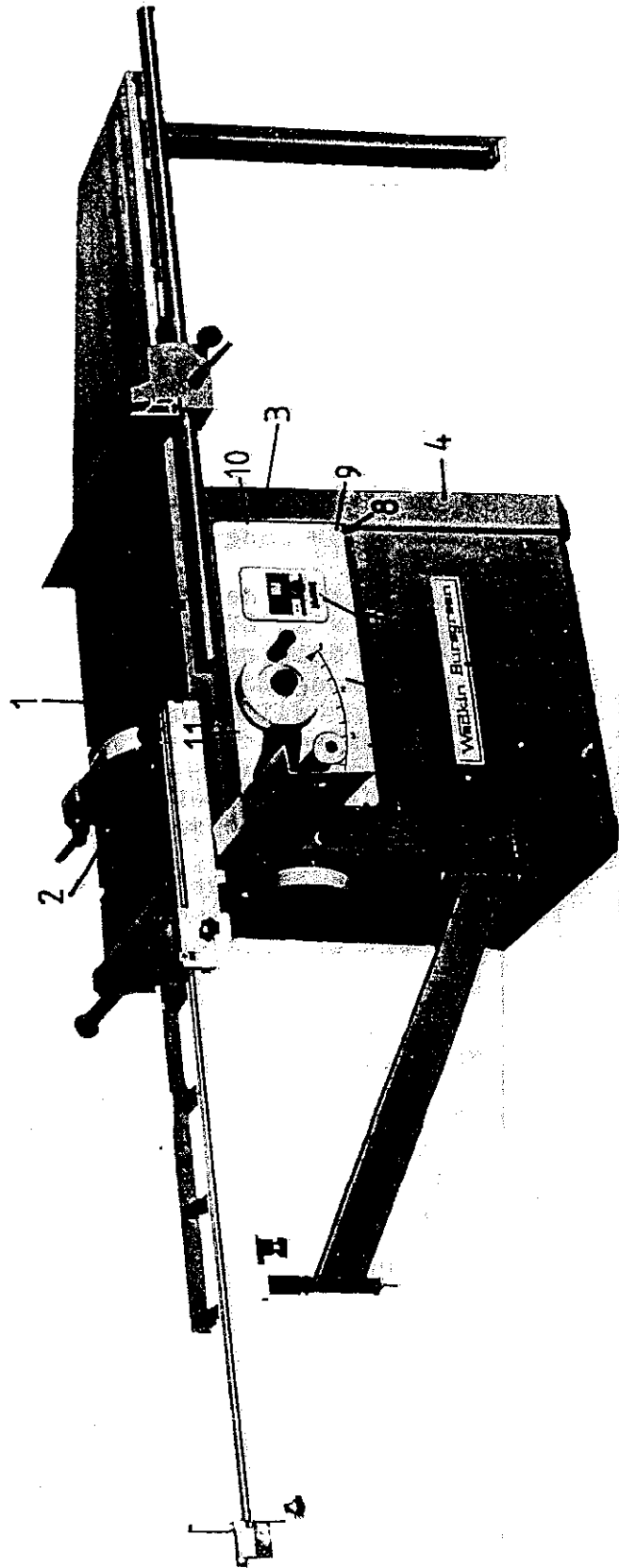

# Wadkin Bursgreen

## ILLUSTRATED PARTS LIST

### ASSEMBLY:- RISE AND FALL AND TRUNNION

FIG ITEM	PART NO. *	UNITS PER ASSEMBLY	DESCRIPTION
20	S25-3	2	Trunnion Slides
21	S25-7	2	Trunnion Trapping Plates
22	SP12-8	1	Rise and Fall Slide Bracket
23	K05-25-503	3	M6 x 20 Long Hexagon Set Screws
24	K05-27-108	3	M6 Locknuts
25		2	M8 x 55 Long Hexagon Set Screws
26	S25-571	1	Trapping Bracket
27	S25-570	1	Retaining Strip
28	S25-14	1	Racked Quadrant for Rise and Fall
29	K05-20-599	2	6 Dia x 30 Long Groverlok Dowels
30	K05-25-531	2	M10 x 30 Long Hexagon Set Screws
31	K05-20-553	2	5 Dia x 30 Long Groverlok Dowels
32	S25-458	1	Worm
33	K06-04-131	1	51104 Thrust Race
34	K51-05-115	2	20 Bore x 25 O/D x 20 Long Oilite Bushes
35	S25-660	1	Canting Pointer
36	K05-26-112	5	M6 x 6 Long Socket Set Screws
37	CP32-154	1	Rise and Fall Handwheel
38	K51-27-139	1	M10 Locking Knob
39	1026-22	1	Handwheel Washer
40	S25-618	1	Rise and Fall Shaft
41	S25-46	1	Rise and Fall Screw Bearing Shaft
42	K05-26-190	1	M12 x 30 Long Dog Point Socket Screw
43	K51-88-800	3	EPL26 Bump Washers
44	SP12-38	1	Rise and Fall Pivot
45	S12-39	1	Washer for Rise and Fall Pivot
46	K05-25-340	2	M10 x 20 Long Countersunk Socket Screws
47	SP12-7	1	Trunnion Bracket
48		4	6 Dia x 12 Long Groverlok Dowels
49	K05-25-516	8	M8 x 20 Long Hexagon Set Screws
50		2	M8 x 16 Long Nicked Brass Grubscrew with M8 Locknuts
51	S25-612	1	Canting Screw
52	CP32-25	1	Stop Nut
53	CP32-26	1	Stop Collar
54	K51-10-407	1	7100-025 External Circlip
55	S25-613	1	Canting Nut Pivot Plate
56	CP32-37	1	Rise and Fall Nut
57	S25-614	1	Locking Nut
58	K51-27-191	1	M10 Locking Handle
59	K51-66-153	1	10mm Grommet
60	K05-26-275	1	M10 x 90 Long Stud
61	1073-127	1	Canting Lock Bush
62	K51-10-405	1	7100-016 External Circlip
63	K05-27-101	2	M8 Nuts
64	K05-28-102	2	6mm Washers
65	K05-25-502	2	M6 x 16 Long Hexagon Set Screws
66	K06-30-413	1	INA FLCTE 16 Flanged Bearing with RHP SLFL16 Inner Bearing
67	BEL-24	1	Tapered Bush for Handwheel
68	K51-27-208	1	Canting Handwheel

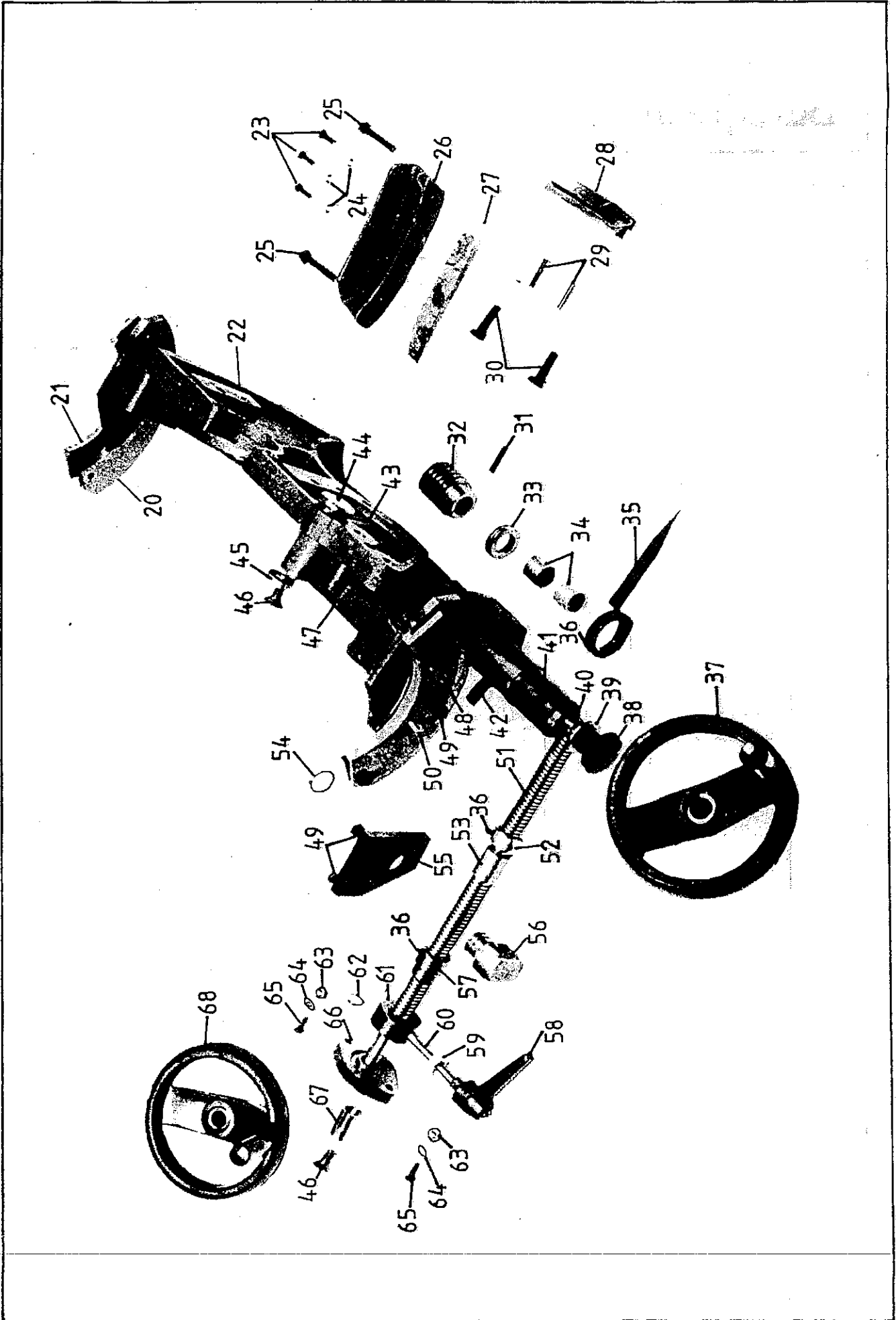

# Wadkin Bursgreen

## ILLUSTRATED PARTS LIST

### ASSEMBLY:- SAW DRIVE MOTOR

FIG ITEM	PART NO. *	UNITS PER ASSEMBLY	DESCRIPTION
75	K05-28-104	12	10mm Washers
76	K05-25-530	4	M10 x 25 Long Hexagon Set Screws
77	K51-04-503	1	220 J8 Poly 'V' Belt
78	SP12-44	1	Motor Pulley (2.2kw, 3ph, 50 cycle)
	SP12-45	1	Motor Pulley (3hp, 3ph, 60 cycle)
	SP12-46	1	Motor Pulley (4kw, 3ph, 50 cycle)
	SP12-47	1	Motor Pulley (3hp, 1ph, 60 cycle) (5hp, 3ph, 60 cycle)
79	K05-26-126	2	M8 x 12 Long Socket Set Screws
80	K51-20-110	1	8 x 7 x 32 Long Feather Key (2.2kw, 3ph, 50 cycle) (3hp, 3ph, 60cycle)
	K51-20-113	1	8 x 7 x 40 Long Feather Key (3hp, 1ph, 60cycle) (4kw, 3ph, 50cycle) (5hp, 3ph, 60cycle)
81	S25-238	1	Motor Platform
82	K05-25-531	4	M10 x 30 Long Hexagon Set Screws
83	K05-27-103	4	M10 Nuts
84	K51-15-108	1	D90S TEFV Motor 2.2kw, 3000rpm, 3ph, 50 cycle
	K51-15-117	1	D90S TEFV Motor 3hp, 3600rpm, 3ph, 60 cycle
	K51-15-102	1	ED100LB TEFV Motor 3hp, 3600rpm, 1ph, 60cycle
	K51-15-133	1	D100L TEFV Motor 4kw, 3000rpm, 3ph, 50 cycle
	K51-15-141	1	D100L TEFV Motor 5hp, 3600rpm, 3ph, 60 cycle

- ITEM NOT ILLUSTRATED

\* PLEASE QUOTE PART & MACHINE  
NUMBER WHEN ORDERING SPARES

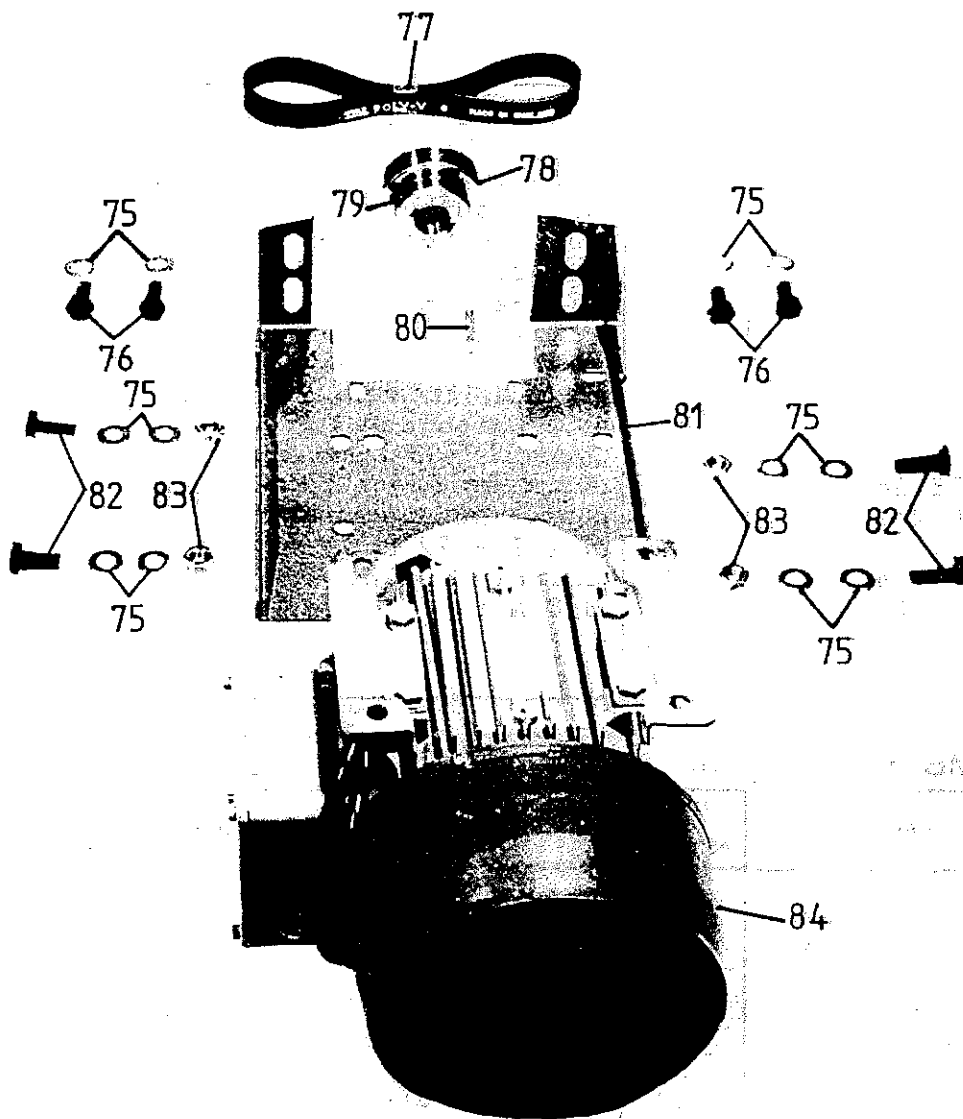



# Wadkin Bursgreen

## ILLUSTRATED PARTS LIST

### ASSEMBLY:- MAIN SAW SPINDLE

FIG ITEM	PART NO. *	UNITS PER ASSEMBLY	DESCRIPTION
90	K51-10-304	1	5100-225 External Circlip
91	S25-550	1	Riving Knife Pivot Bracket
92	S25-101	1	Spindle Housing
93	K05-25-531	3	M10 x 30 Long Hexagon Set Screws
94	K05-26-114	2	M6 x 10 Long Socket Set Screws
95	S25-41	1	Spindle Locking Collar
96	K06-01-192	2	6203-2RS Bearings
97	K05-25-209	1	M10 x 25 Long Socket Capscrew
98	S25-394	1	Spindle Trapping Collar
99	S25-40	1	Spindle Distance Piece
100	SP12-42	1	Saw Spindle Nut
101	SP12-107	1	20mm, 1" and 25mm Bore Front Saw Flange
	S25-98	1	30mm Bore Front Saw Flange
102	SP12-57	1	20mm Spindle Assembly
103	K51-20-176	1	5 x 9 x 22 Long Woodruff Key
104	SP12-43	1	Spindle Pulley
105	K05-25-105	1	M16 Nut

### ASSEMBLY:- SCORING SAW

FIG ITEM	PART NO. *	UNITS PER ASSEMBLY	DESCRIPTION
110	K51-27-141	1	M12 Blind Handwheel
111	K51-27-104	1	M12 Nut
112	K05-28-105	1	12mm Washer
113	SP12-151	1	Tension Spindle
114	K51-10-201	2	7000-028 Internal Circlips
115	SP12-182	1	Scoring Saw Tension Pulley
116	K06-01-107	1	6001-2RS Bearing
117	K05-28-103	1	8mm Washer
118		1	M8 x 12 Long Socket Button Head Screw
119	K51-10-404	1	7100-015 External Circlip
120	K51-88-807	2	EPL 11 Bump Washers
121	K06-01-149	2	6002-2RS Bearings
122	SP12-23	1	Bearing Spacer
123	K51-10-413	1	7100-018 External Circlip
124	SP12-206	1	Scoring Saw Spindle
125	K51-10-402	1	7000-032 Internal Circlip
126	SP12-139	1	Scoring Saw Pulley
127	SP12-118	1	Washer
128	1041-76	1	Scoring Saw Nut
129	K51-61-161	1	Plastic End Tip
130	SP12-207	1	Bot for Scorer Spindle Lock
131		1	M12 x 20 Long Plain Cup Socket Set Screw
132	K51-27-111	1	M12 Locknut
133	K51-04-509	1	260 J4 Poly 'V' Belt

- ITEM NOT ILLUSTRATED

\* PLEASE QUOTE PART & MACHINE  
NUMBER WHEN ORDERING SPARES

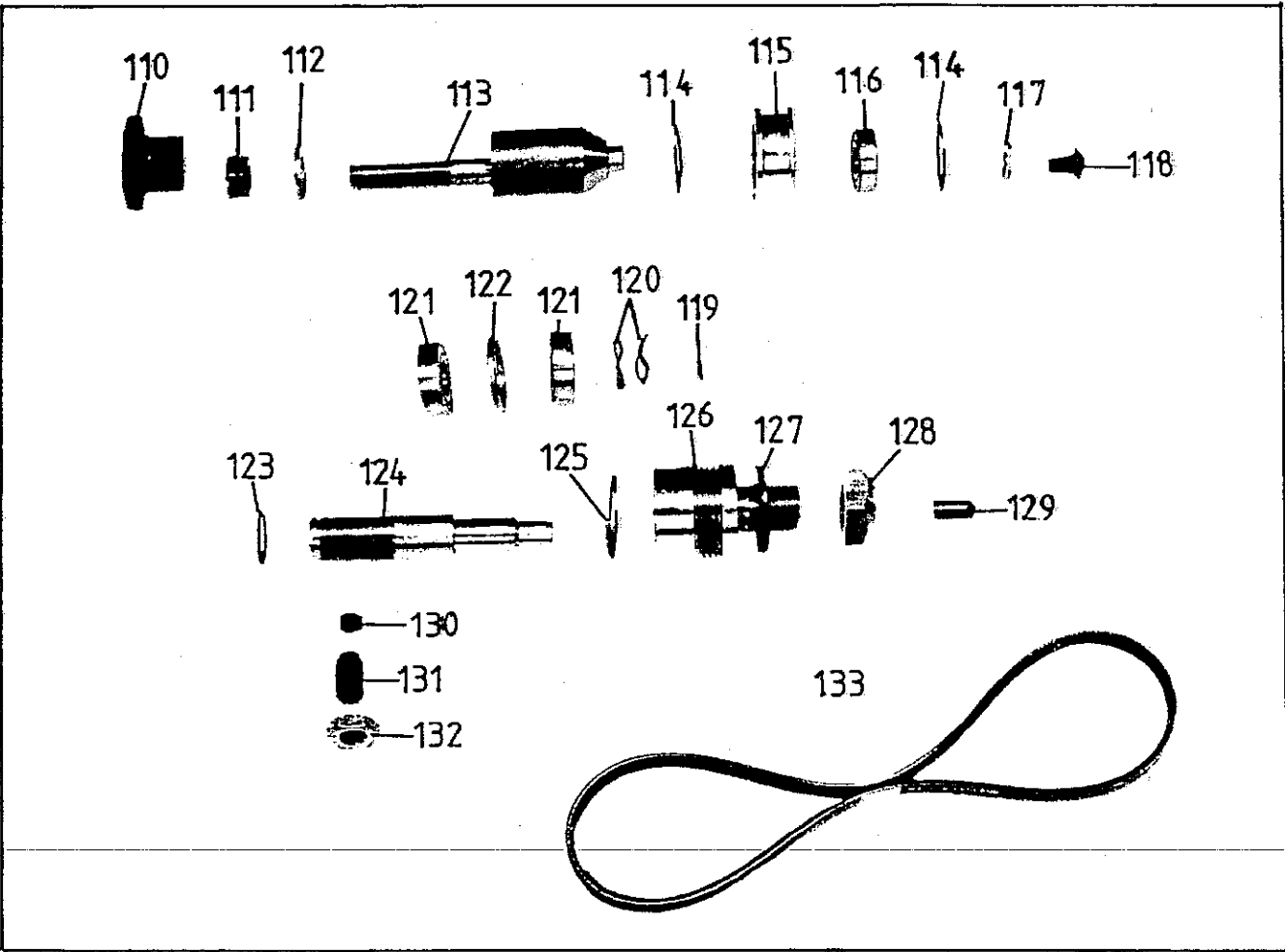
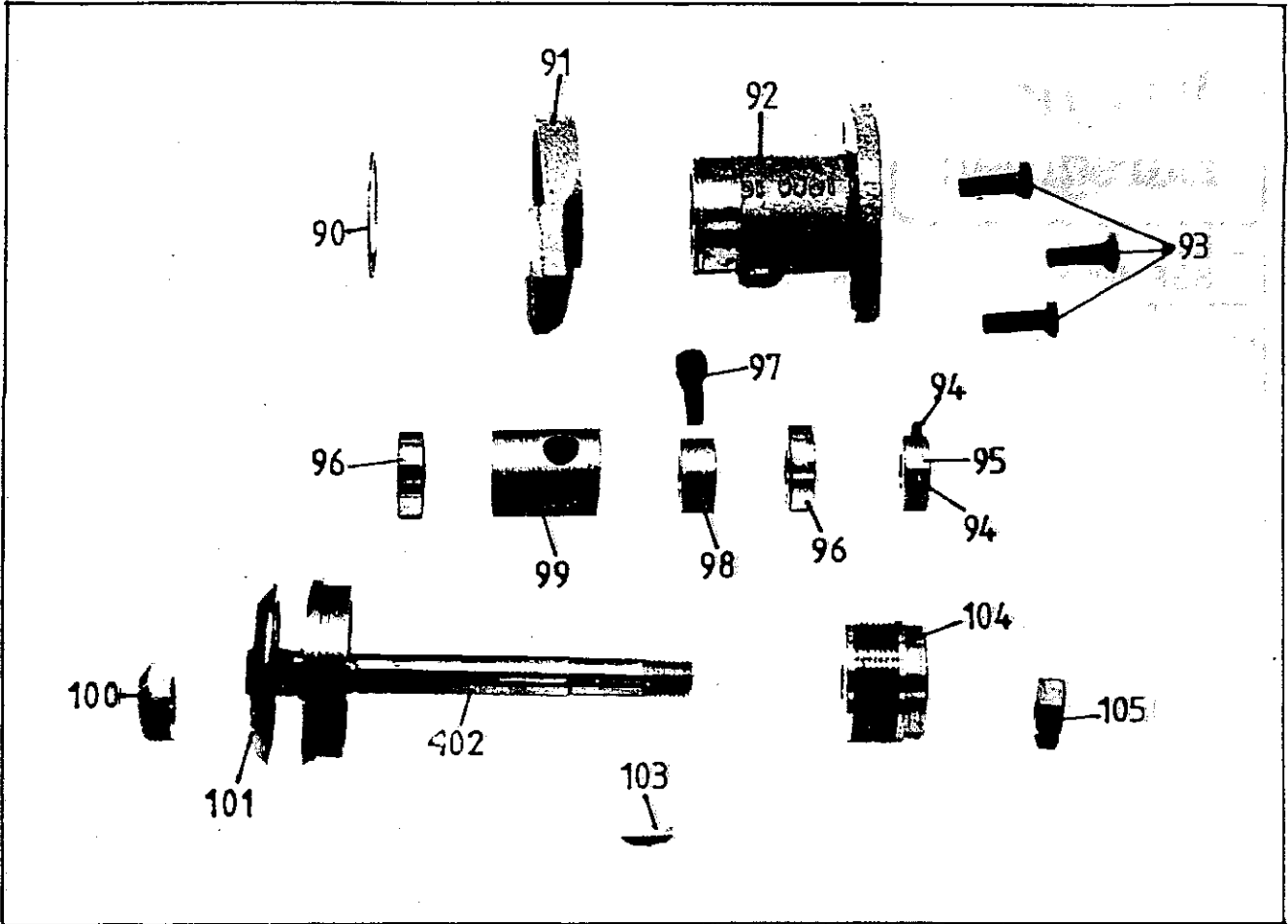

# Wadkin Bursgreen

## ILLUSTRATED PARTS LIST

### ASSEMBLY:- RIVING KNIFE AND SAWGUARD

FIG ITEM	PART NO. *	UNITS PER ASSEMBLY	DESCRIPTION
135	SP12-163	2	Locking Knobs for Sawguard Visor
136		2	M6 x 16 Long Studs
137	K51-19-163	2	6mm Fibre Washers
138	SP12-64	1	Sawguard
139	K05-25-533	1	M10 x 40 Long Hexagon Set Screw
140	1069-293	1	Washer
141	K51-27-191	1	M10 Adjusting Handle
142	SP12-162	1	Sawguard Visor
143	S25-358	1	Riving Knife
144	S25-550	1	Riving Knife Pivot Bracket
145	S25-376	1	Locknut
146	K51-10-403	2	7100-012 External Circlip
147	S25-552	1	Link Plate Pivot Pin
148	S25-363	1	Rise and Fall Link Plate
149	K05-25-187	2	M8 x 20 Long Socket Capscrews
150	S25-551	1	Slide Plate for Riving Knife
151		2	M8 x 35 Long Socket Button Head Screws
152	S25-369	1	Bear Clamp Plate
153	S25-359	1	Riving Knife Guide Plate
154	S25-368	1	Pressure Plate
155	S25-370	1	Front Clamp Plate
156	S25-537	1	Clamp Screw

— ITEM NOT ILLUSTRATED

\* PLEASE QUOTE PART & MACHINE  
NUMBER WHEN ORDERING SPARES

(C)

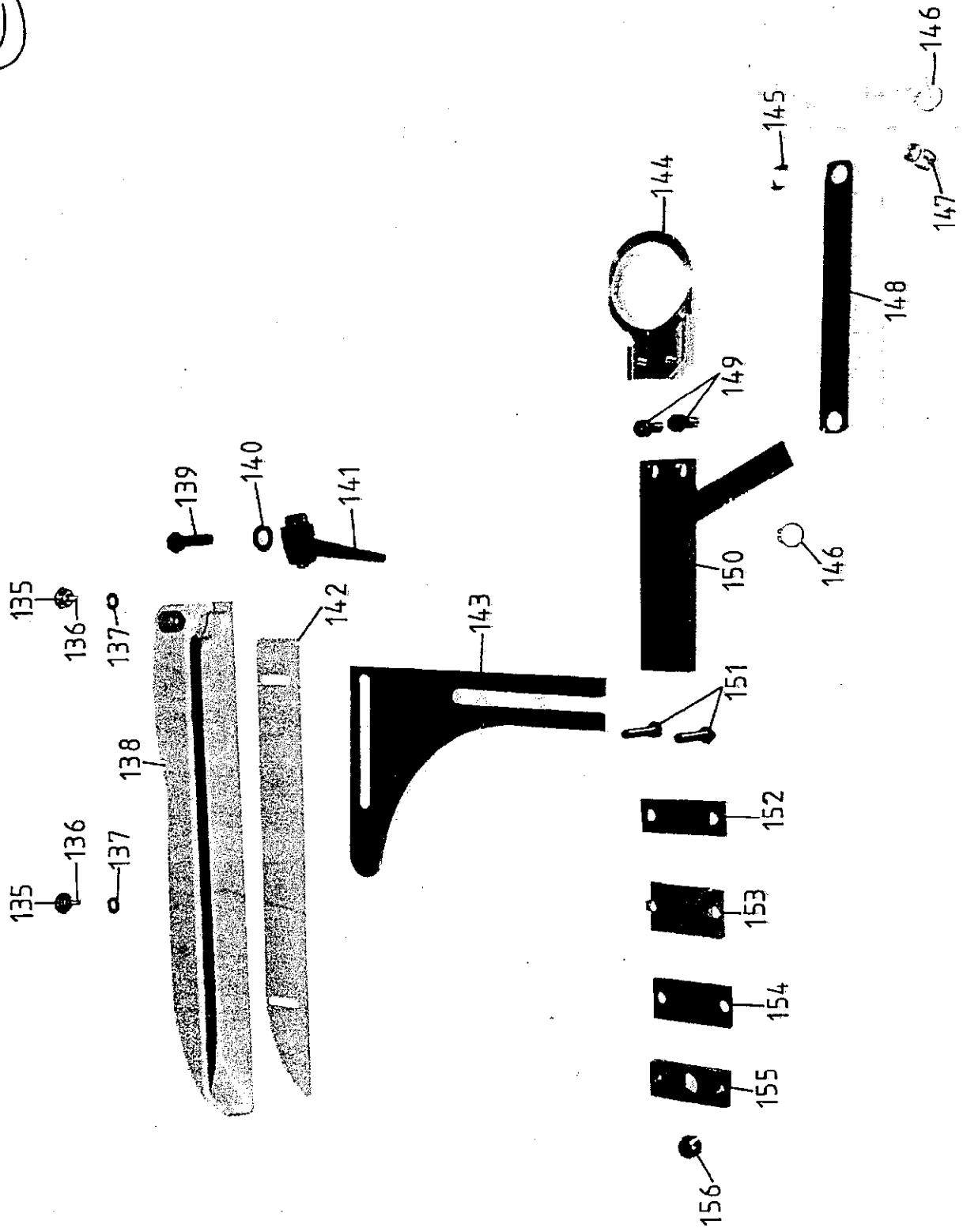



## ILLUSTRATED PARTS LIST

ASSEMBLY:- RIP FENCE			
FIG ITEM	PART NO. *	UNITS PER ASSEMBLY	DESCRIPTION
160	S25-603	1	Rip Fence Front Plate
161	S25-532	1	Stud for Rip Fence Front Plate 90mm Long
	S25-596	1	Stud for Rip Fence Front Plate 120mm Long
162	S25-624	1	Rip Fence
163	K05-28-103	2	8mm Washers
164	K51-27-127	2	M8 Locking Knobs
165	K05-25-531	1	M10 x 30 Long Hexagon Set Screws
166	K06-30-402	1	O-4705-00 CGR Roller
167	K05-27-103	2	M10 Nuts
168	K05-26-116	1	M6 x 16 Long Socket Set Screw
169	S25-605	1	Rip Fence Roller Spring
170	K05-25-500	2	M6 x 10 Long Hexagon Set Screws
171	K05-28-104	1	10mm Washer
172	S25-652	1	Rip Fence Support Bar
173	S25-60	1	Pointer
174	S25-360	1	Pointer Bar
175		1	M10 x 25 Long Brass Machine Screw
176	S25-64	1	Locking Plate
177		2	5 Dia x 12.7 Long Pop Rivets
178	K05-26-269	1	M10 x 60 Long Stud
179	K51-27-191	1	M10 Adjusting Handle
180	S25-635	1	Pinion Spring Retainer
181	K51-73-140	1	ETS18 Compression Spring
182	K06-30-408	1	6 Dia Steel Ball
183	S25-634	1	Pinion for Rip Fence
184	K51-05-103	2	9 Bore x 14 O/Dia x 14 Long Oilite Bushes
185	K51-27-137	1	8mm Plain Handwheel
186	K05-27-103	2	M10 Nuts
187	K05-25-104	2	10mm Washers
188	K05-27-110	4	M10 Locknuts
189	K05-26-270	2	Studs for Rip Fence
190	P32-329	1	Rip Fence Bar
191	K05-25-163	1	M6 x 10 Long Socket

- ITEM NOT ILLUSTRATED

\* PLEASE QUOTE PART & MACHINE  
NUMBER WHEN ORDERING SPARES

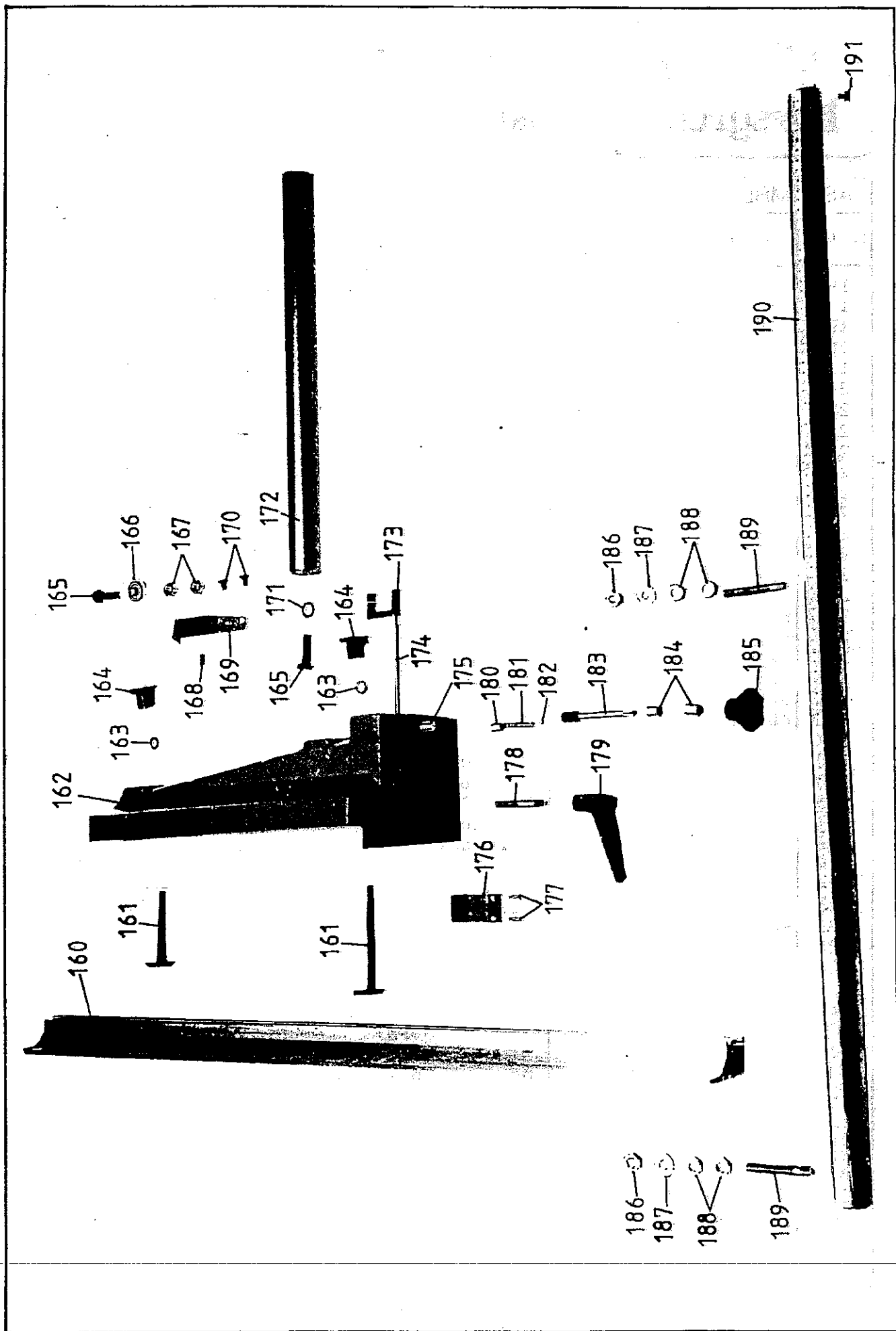

# Wadkin Bursgreen

## ILLUSTRATED PARTS LIST

ASSEMBLY:-		SLIDING TABLE	
FIG ITEM	PART NO. *	UNITS PER ASSEMBLY	DESCRIPTION
195	K05-27-113	2	M20 Locknuts
196	S25-644	1	Outer Pivot Stud
197	S25-642	1	Outer Support
198	K06-01-172	1	6200-2RS Bearing
199		1	10 x 30 long Hardened Ground Dowel
200	S25-641	1	Pivot Arm
201	K51-05-155	2	Flange Dilite Bushes
202		4	M8 x 20 Long Dog Point Screws
203	S25-4	1	Pivot Bracket
204	K05-25-531	4	M10 x 30 Long Hexagon Set Screws
205	S25-43	1	Pivot Bar
206	K05-25-528	2	M10 x 16 Long Hexagon Set Screws
207	S25-412	1	Slide Bar End Stop Washer
208	S25-687	2	Corded Rubber Rings
209	S25-47	1	Slide Bar
210	K05-25-214	1	M10 x 50 Long Socket Capscrew
211	K51-10-203	4	7000-035 Internal Circlips
212	K06-01-314	4	6300-2RS Bearings
213	S25-20	2	Sliding Table Rollers
214	S25-54	2	Bearing Distance Pieces
215	S25-63	3	Bearing Inside Distance Pieces
216	K05-25-530	2	M10 x 25 Long Hexagon Set Screws
217		1	M10 x 20 Long Nicked Brass Grubscrew
218	K05-27-110	1	M10 Locknut
219	S25-24	1	Bearing Plate
220	K51-99-103	1	M10 x 35 Long Brass Stud
221	K51-27-191	1	M10 Locking Handle
222	K05-27-111	2	M12 Locknuts
223	S25-44	2	Top Bearing Pins
224	K06-01-185	2	6202-2RS Bearings
225	S25-546	2	Slide Bar Wipers
226	EM-391	2	Trapping Washer for Wiper
227		2	M5 x 8 Long Countersunk Socket Screws
228	K05-25-219	1	M10 x 75 Long Socket Capscrew
229	S25-61	1	Adjuster for Front Bearing
230	1041-126	1	M20 Locknut
231	K05-28-104	4	10mm Washers
232	K05-27-103	3	M10 Nut
233	K05-26-234	2	M8 x 30 Long Studs
234	K51-27-148	2	M8 Aerotight Nuts
235		1	M10 x 35 Long Stud
236	K51-27-142	2	M8 Locking Knobs
237		1	M8 x 40 Long Stud
238	S25-479	1	Inner Fence Support Block
239	S25-686	1	Slide Bar Roller Cover
240	S25-661	1	Sliding Table
241		1	M8 x 30 Long Stud
242	S25-422	1	Outer Fence Support Block

- ITEM NOT ILLUSTRATED

\* PLEASE QUOTE PART & MACHINE  
NUMBER WHEN ORDERING SPARES

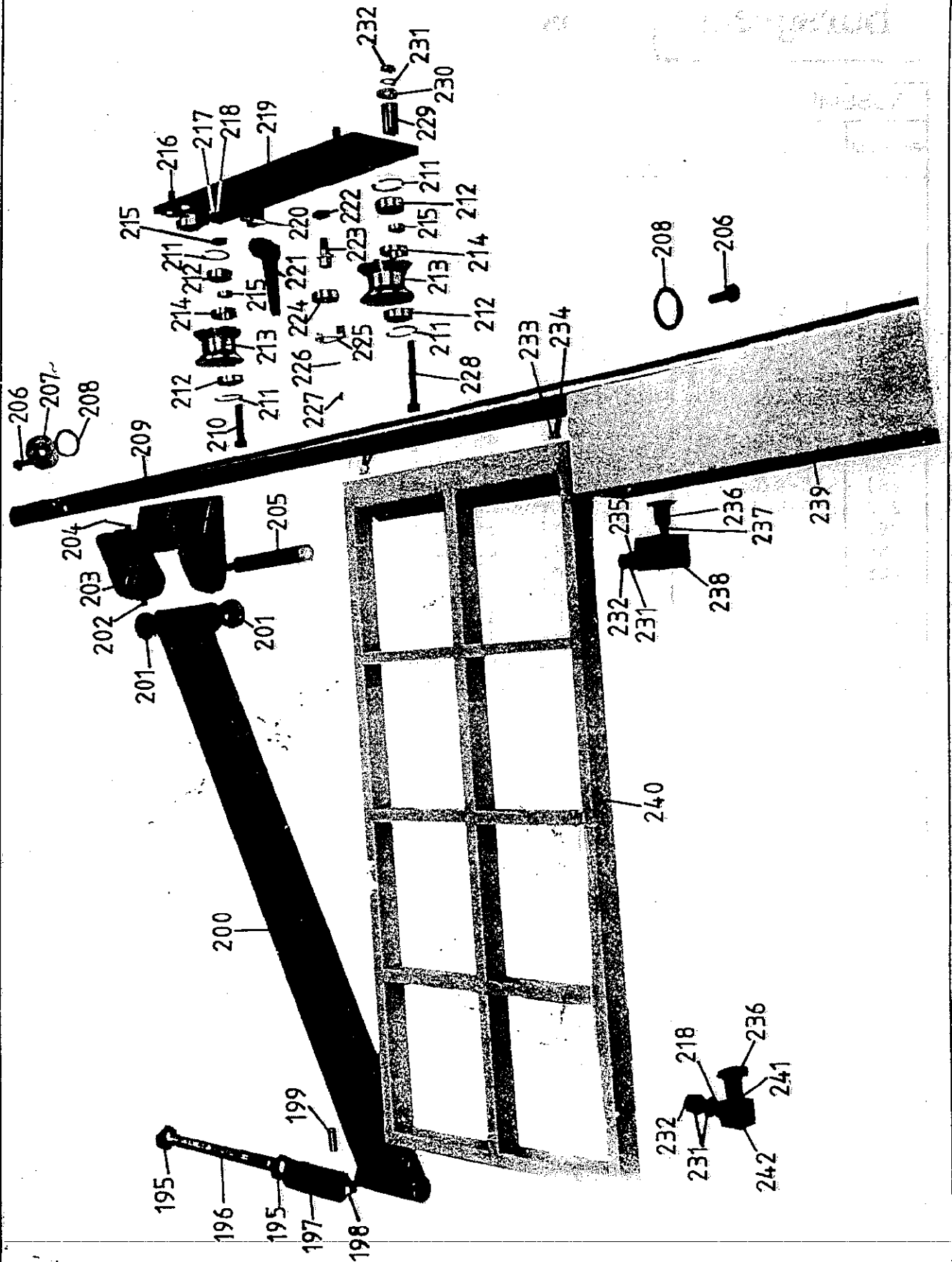



# Wadkin Bursgreen

## ILLUSTRATED PARTS LIST

ASSEMBLY:- CROSSCUT FENCE			
FIG ITEM	PART NO. *	UNITS PER ASSEMBLY	DESCRIPTION
248	K51-27-127	1	M8 Locking Knob
249	K05-26-234	1	M8 x 30 Long Stud
250	K05-26-112	1	M6 x 6 Long Socket Set Screw
251	1073-347	1	Locking Boss for Extension
252	S25-447	2	Locking Boss
253	S25-535	2	Locking Plate
254	K05-25-319	4	M5 x 20 Long Countersunk Socket Screws
255	SP12-146	1	Turnover Stop
256	K51-27-126	1	M6 x Locking Knob
257	K05-28-102	1	6mm Washer
258	SP12-148	1	Turnover Stop Bracket Right Hand
259	K05-26-208	1	M6 x 45 Long Stud
260	BEL-102	1	Shoe for Turnover Stop
261	S25-420	1	Crosscut Fence
262	S25-681	1	Crosscut Fence Extension
263		1	M10 Dome Nut
264	K05-27-110	1	M10 Locknut
265		1	M10 x 75 Long Countersunk Machined Screw
266	CP32-210	1	Pivot Block
267		1	M6 x 12 Long Socket Capscrew
268		1	M6 x 20 Long Countersunk Socket Screw
269	CP32-214	1	Turnover Stop
270	S25-680	1	Turnover Stop Rest

- ITEM NOT ILLUSTRATED

\* PLEASE QUOTE PART & MACHINE  
NUMBER WHEN ORDERING SPARES

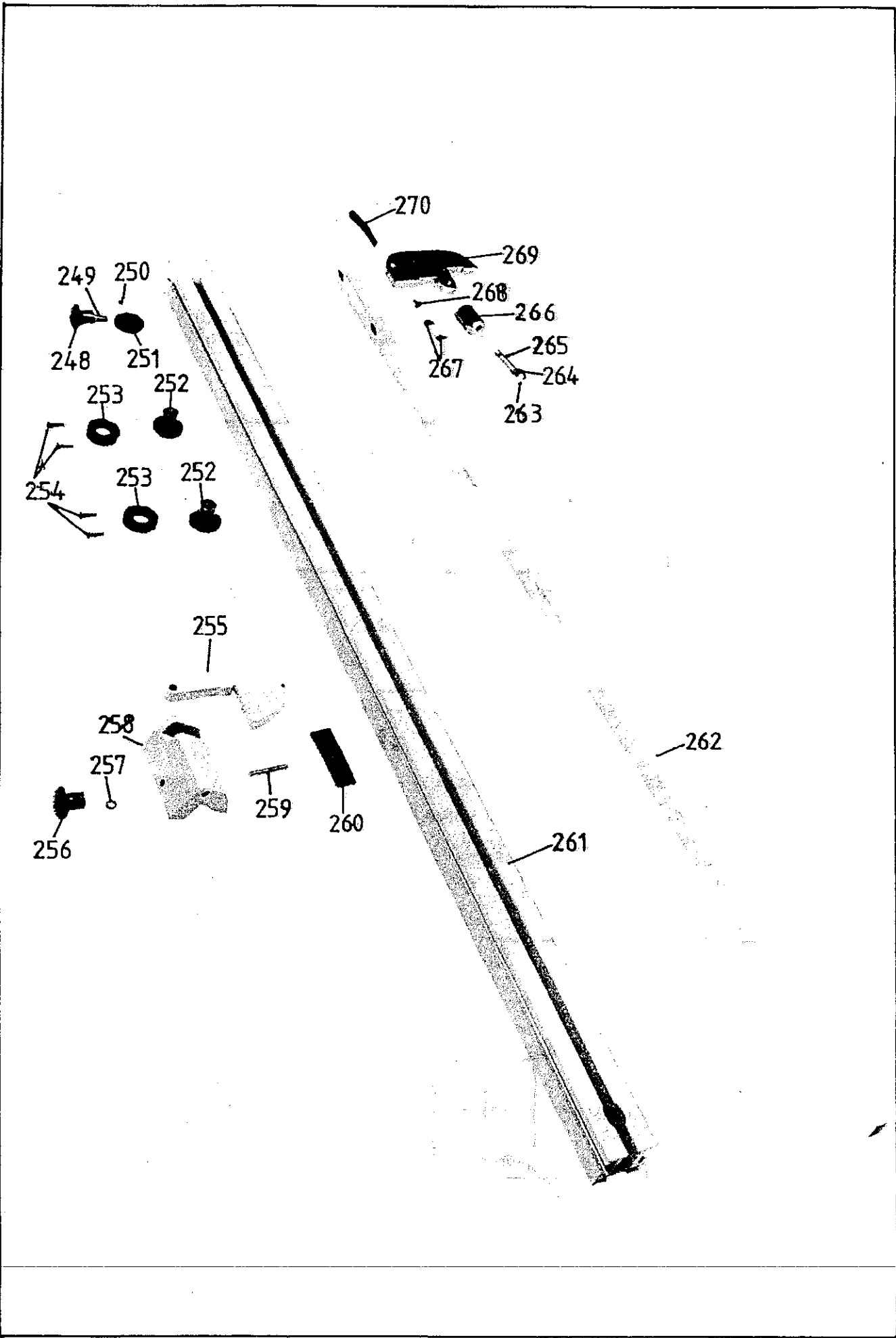

MAINTENANCEGENERAL

- 1) Regularly clear chips and dust from inside the machine.
- 2) Clean saw spindles from time to time with resin solvent and lightly oil.

All machines leave our factory with all fences etc., precisely set, should any of these settings require adjustments at a later date, proceed as follows:-

RIP FENCE ALIGNMENT, FIG.34

Loosen locknuts on the outer of the two bolts holding the rip fence bar, reset locknuts and retighten in new position, retighten nut behind main table

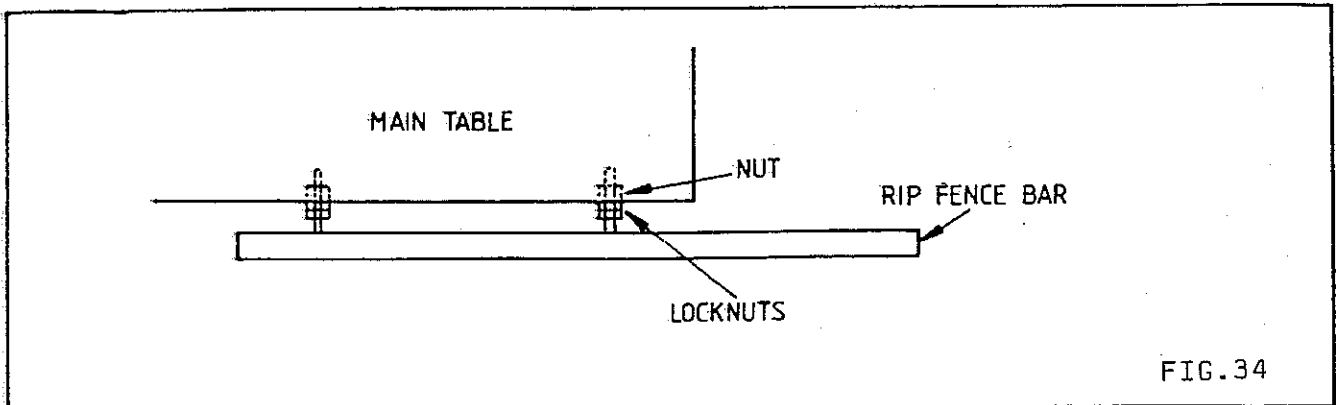

FIG.34

CROSSCUT FENCE SQUARENESS FIG.35

The crosscut fence is held to edge of sliding table by 2 location support blocks. To adjust, if fence is out of square, loosen nut and locknut on the outer of the 2 support blocks, reset and retighten in new position.

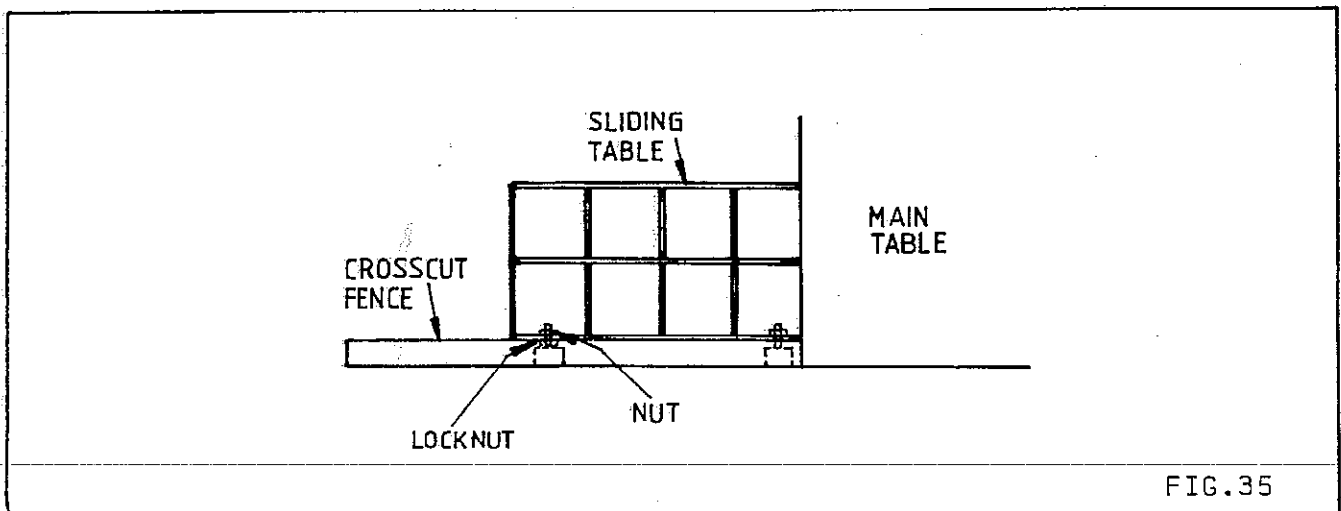

FIG.35

### SETTING SAW TO RIVING KNIFE

The saw and riving knife are preset at works and require no adjusting unless spindle bearings have been changed or saw is cutting out of line, proceed as follows:-

- 1) Loosen the socket head capscrew 'A' in FIG.35 with 8mm allen key (supplied with machine) and tap spindle (with hide face hammer) as required, taking care not to damage the threads on spindle ends.

Place a steel rule along both sides of riving knife to check that saw is central.

- 2) When set, re-tighten the socket head capscrew.
- 3) To check this setting, feed a short piece of timber from the rear, along both sides of the riving knife. If riving knife is set correctly, the blade will cut equal shoulders as shown in FIG.37A and when set incorrectly, unequal shoulders as shown in FIG.37B.

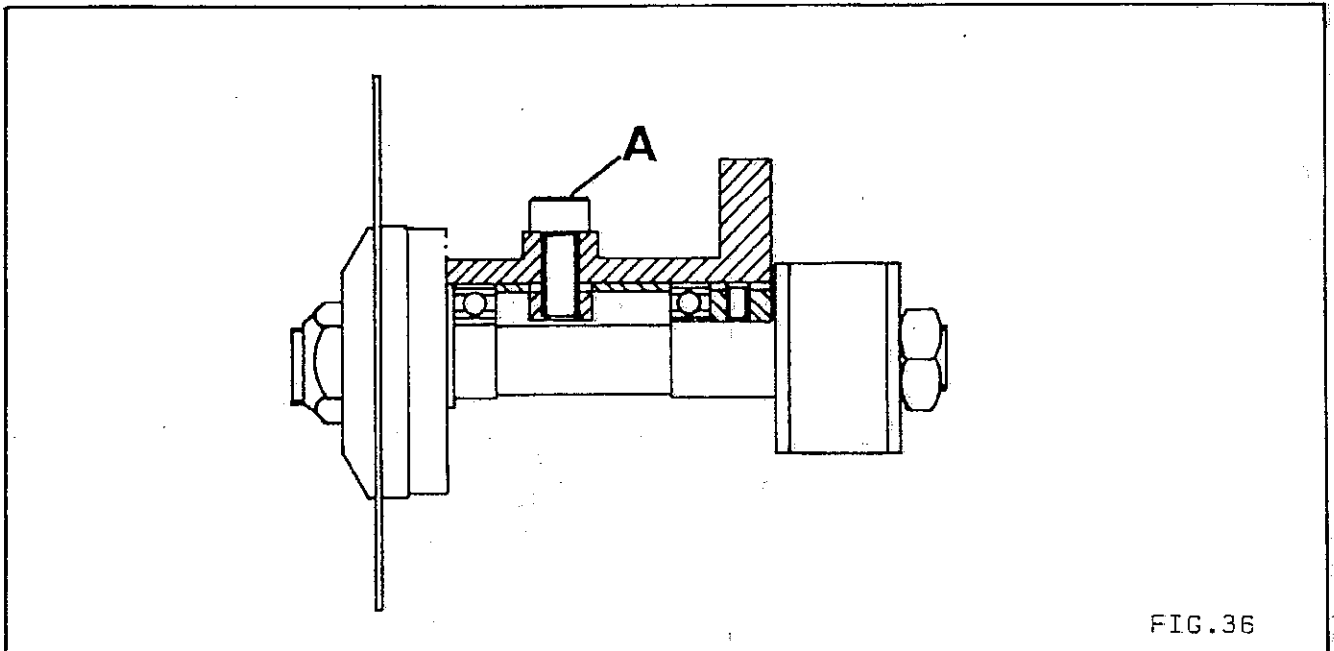

FIG.36

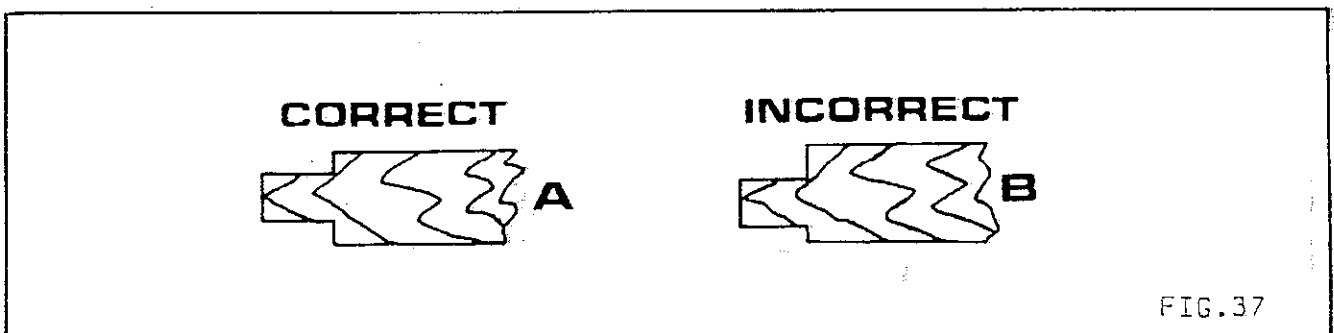

FIG.37

SETTING TABLE IN LINE WITH SAW

The table grooves are accurately set before despatch, but should the table be disturbed in transit or for any other reason, the undermentioned procedure should be followed to set the table grooves parallel to the saw:

- 1) Isolate machine electrically.
- 2) Loosen the four M10 nuts securing the table to main frame.
- 3) With the saw fitted to arbor, select a tooth and position straight stop rod of mitre fence so that it just touches the saw as shown in FIG.38.
- 4) Slide mitre fence to rear position of the saw, swing tooth of saw which was used in item 2. Check whether the stop rod touches the tooth by the same amount. Should the slot be out of alignment with the saw, position table until correct. The correct position of the saw in relation to the table insert slot is 25.4mm (1") from the right hand side. This will ensure clearance on the table insert when the saw is canted. When set, tighten all screws.
- 5) To check this alignment, cut several pieces of wood using the mitre fence to ensure there is no back cut as the stock is passed through the sawblades.

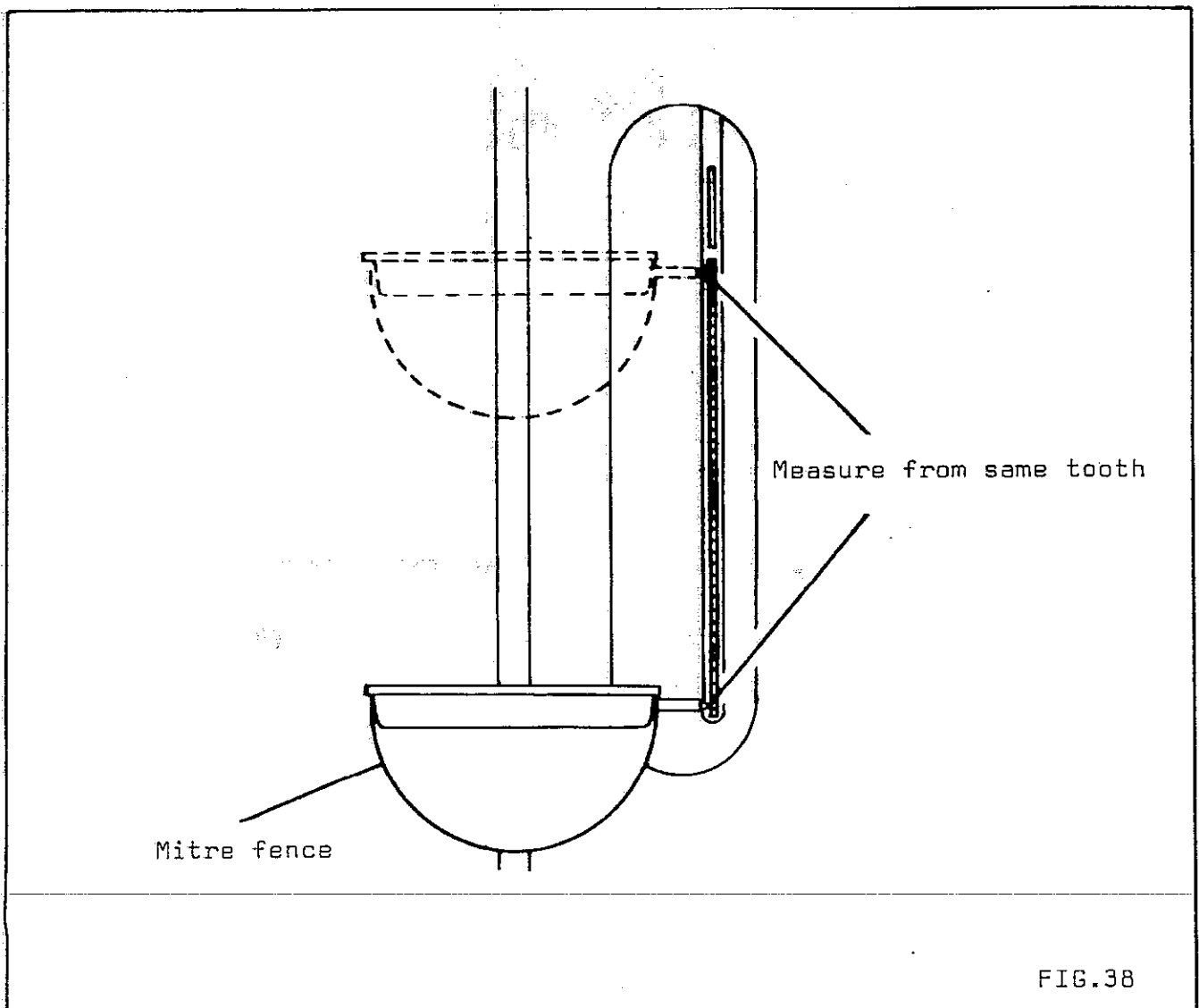

FIG.38

BREAKOUT OF PANELS

- 1) Blunt or incorrect sawblades.
- 2) Scoring saw not in correct alignment to main sawblade refer to page 21 for correct alignment.
- 3) Scoring using rip fence. Scoring should be done using sliding table.
- 4) Riving knife misalignment.

FITTING WOBBLE SAW (EXTRA)

To fit wobble saw, proceed as follows:-

- 1) Isolate machine electrically.
- 2) Remove the table insert, riving knife complete with sawguard and front saw flange. Keep these in a dry, safe place.
- 3) Screw wobble saw to saw spindle as shown in FIG.39.
- 4) All that is now required is to set the saw to give the size of slot which is required to be cut.
- 5) To adjust saw loosen nut 'A' and move saw complete with large collars to required position. When set, relock nut 'A'.

Maximum diameter of saw which can be used is 152mm (6") which will cut any width of groove between 3mm and 16mm (1/8" and 5/8") to a maximum depth of 25.4mm (1").

Table insert ref no. S25/670 should be used when the wobble saw is fitted.

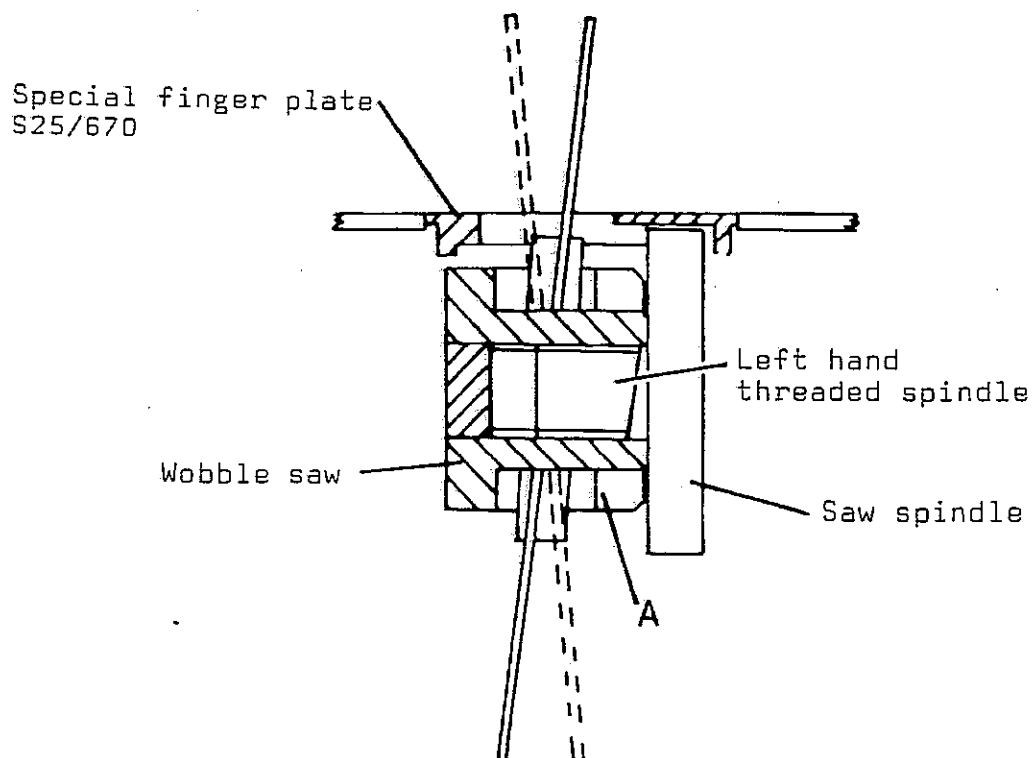

FIG.39

### FITTING DADO HEAD (EXTRA)

A dado head is made up of two outside saws and four inner cutters. Various combinations of saws and cutters can be used to cut grooves 3mm to 21mm (1/8" to 13/16") wide. Inner cutters are heavily swaged and must be arranged so that the heavy portion falls in the gullets of the outside saws, as shown in FIG.40A.

FIG.40B shows how the saws and cutters overlap, 'D' being the saw and 'E' being the inside cutter.

A 6mm (1/4") groove is cut by using the two outside saws fitting the ground teeth directly opposite as shown in FIG.40C in order to allow clearance for the slight set of the saw teeth.

The dado head is secured to the saw spindle by means of a special knurled locking nut as shown in FIG.41.

NOTE: Isolate machine electrically before fitting dado.

To fit dado head, remove the table insert, riving knife complete with sawguard and front saw flange.

Fit the outer saws and required inner cutters on the spindle and lock in position with the special knurled locking nut.

The table insert No. S25/669 should be used when a dado head is fitted.

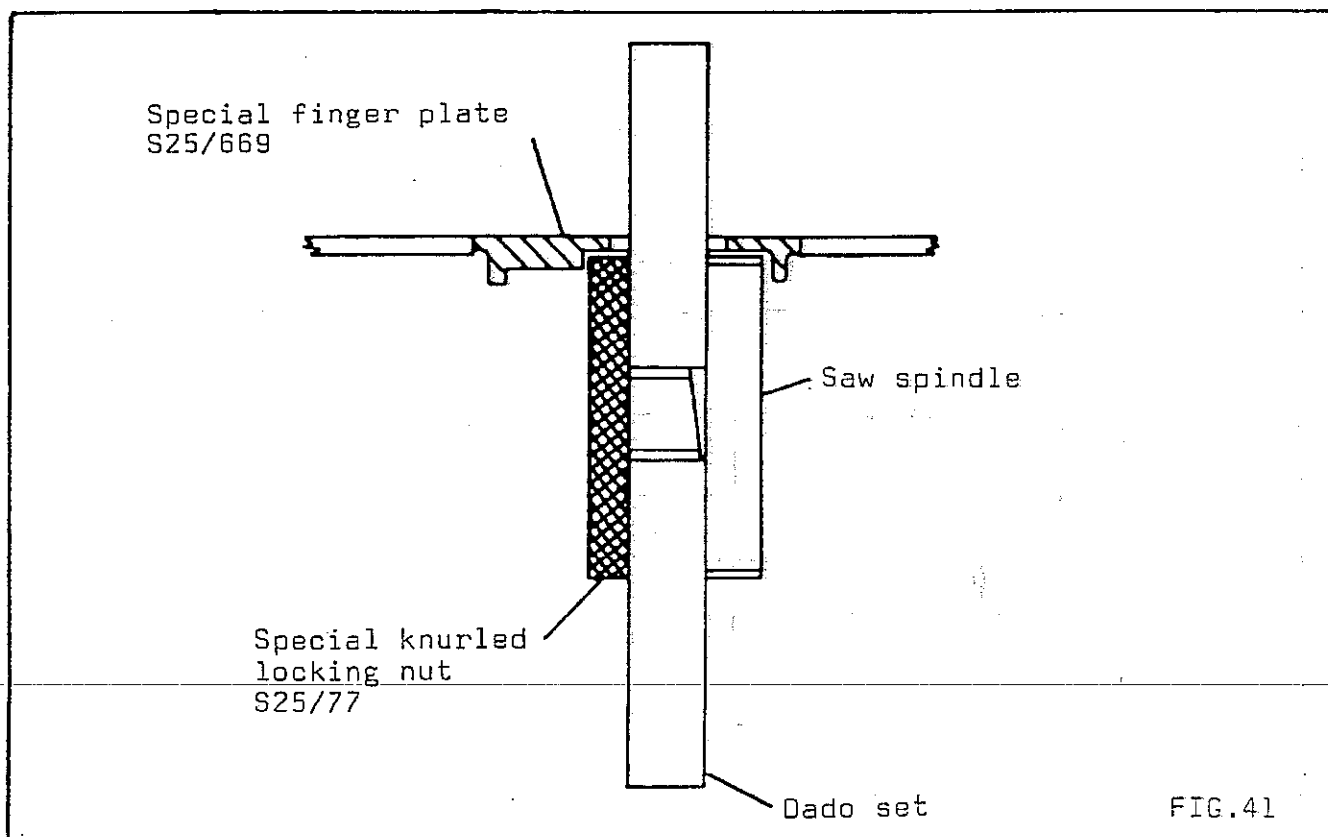
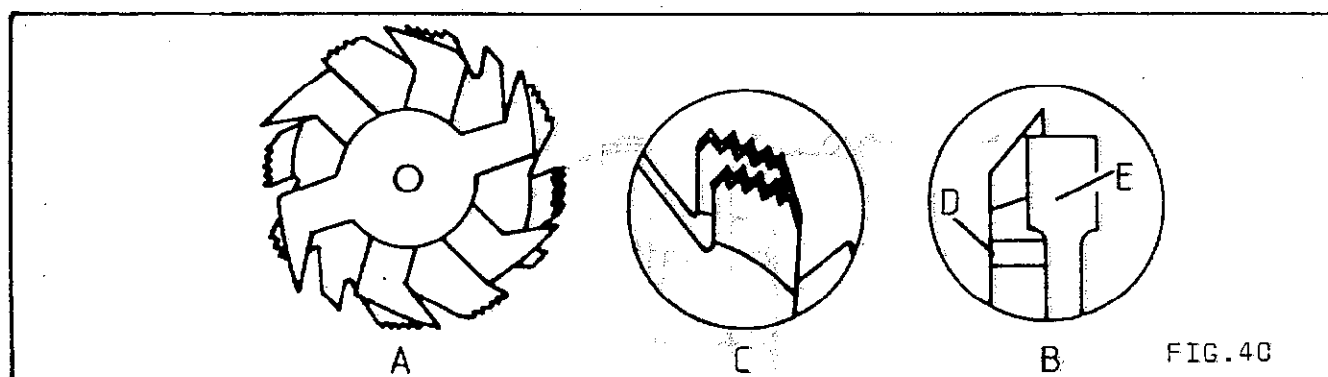



### FITTING MOULDING CUTTERBLOCK (EXTRA)

NOTE: Isolate machine electrically before fitting cutterblock.

The cutterblock is 124mm (4.7/8") dia x 19mm ( $\frac{3}{4}$ ") wide and takes 5/32" (4mm) or  $\frac{1}{4}$ " (6mm) thick cutters. The cutterblock is secured to the spindle by means of the standard arbor nut without the front saw flange, as shown in FIG.42.

The procedure when fitting the cutterblock is similar to that when fitting the wobble saw and dado set.

The table insert, ref No. S25/670 should be used when the cutterblock is fitted.

When using the cutterblock, it is necessary to face the fence with a wood facing, to span the cutters so that only the required amount of cutters are exposed when making a moulding. The approximate sizes of such a facing are shown in FIG.43.

The facing is secured to the fence with wood screws through the holes provided.

Before securing the knives, always ensure that the slots and cutters are free from sawdust and dirt.

