

***INSTRUCTION AND
OPERATING MANUAL FOR***

AGC

***FOUR SIDE MOULDERS AND
PLANERS***



T: 0116 2769111

F: 0116 2598138

MAINTENANCE AND OPERATING
INSTRUCTIONS FOR:
FOUR-SIDE MOULDERS AND PLANERS
MODEL A.G.C.

GENERAL

S A G A R FOUR SIDE MOULDERS AND PLANERS (AGC) HAVE BEEN DEVELOPED ON CERTAIN SPECIFIC LINES WITH SPECIFIC ENDS IN VIEW.

THE PURPOSE BEHIND THE MACHINE MAY GENERALLY BE SUMMARISED AS FOLLOWS :-

- (1) TO PROVIDE A VERY COMPACT GENERAL PURPOSE MOULDER, FULLY MOTORIZED, TAKING UP A MINIMUM OF FLOOR SPACE, AND SELLING AT A PRICE WHICH BRINGS IT WITHIN THE FINANCIAL MEANS OF A SMALL WOODWORKING USER, WHO OTHERWISE WOULD NOT BE ABLE TO AFFORD THE ADVANTAGES OF FOUR-SIDE MOULDING, & PLANING
- (2) TO PROVIDE A MACHINE OF THE MOST UNIVERSAL APPLICATION, REDUCING SETTING-UP TIME TO A MINIMUM, AND GIVING THE GREATEST POSSIBLE ACCESSIBILITY TO PRESSURES, ADJUSTMENTS, CUTTERBLOCKS, ETC., TO PROVIDE FOR QUICK CHANGE FROM ONE JOB TO THE NEXT.

AS THIS MACHINE MAY THEREFORE BE DESCRIBED AS A "MAID OF ALL WORK", OR A "BREAD AND BUTTER" MOULDER, THE VARIETY OF WORK IT MAY BE CALLED UPON TO PERFORM IN ONE SHOP MAY BE GREAT, AND THIS THEREFORE DEMANDS VERY CAREFUL ATTENTION ON THE PART OF THE OPERATOR, IN USING INTELLIGENCE IN THE SET-UP OF THE MACHINE IN THE WIDE RANGE OF WORK IT MAY BE CALLED UPON TO PERFORM.

THE SIDE AND TOP PRESSURES HAVE BEEN CAREFULLY DESIGNED TO PROVIDE, AS FAR AS POSSIBLE, THE WIDEST ARRANGEMENTS FOR VARYING SIZES AND SHAPES OF MATERIAL. IT MUST, HOWEVER, BE EMPHASIZED VERY STRONGLY, THAT NO MACHINE MANUFACTURER CAN PROVIDE PRESSURES AND EQUIPMENT TO COVER EVERY APPLICATION THAT A WOOD-WORKING MACHINE OF THIS TYPE HAS TO CATER FOR.

IT WILL BE SEEN THAT WHEREVER SPECIALLY SHAPED PRESSURES MAY BE REQUIRED TO BE FITTED, THIS MOULDER IS FITTED WITH LOOSE PRESSURE SHOES. THIS IS DONE INTENTIONALLY, SO THAT AN OPERATOR MAY USE HIS OWN INTELLIGENCE AND SKILL TO THE UTMOST, BY REPLACING THESE BY SUITABLE WOODEN SHOES WHEREVER DESIRABLE.

THE FOLLOWING TABLE GIVES THE PRINCIPAL DIMENSIONS OF THE TWO SIZES OF THIS MACHINE :-

	NO.1 SIZE		NO.2. SIZE	
	ENGLISH	METRIC	ENGLISH	METRIC
CAPACITY	4" x 3"	102 x 76 MM	7" x 4"	178 x 102 MM
SPEEDS OF CUTTERHEADS	6000 R.P.M.	6000 R.P.M.	5000 R.P.M.	5000 R.P.M.
FEED SPEEDS	15,30,38,46 75.115 F/MIN.	5,9,12,14 23.35 MET.MIN.	15,30,38,46 75.115 F/MIN.	5,9,12,14 23.35 MET.MIN.
TOP AND BOTTOM CUTTERHEAD MOTORS	5 H.P.	5 H.P.	7½ H.P.	7½ H.P.
SIDE HEAD MOTORS	4 H.P.	4 H.P.	5 H.P.	5 H.P.
EXTRA BOTTOM HEAD MOTORS	3 H.P.	3 H.P.	5 H.P.	5 H.P.
THROATING HEAD MOTORS	3 H.P.	3 H.P.	3 H.P.	3 H.P.
FEED MOTOR	3 H.P.	3 H.P.	5 H.P.	5 H.P.
MAX. DIAM. OF CUTTING CIRCLE				
MIN. DIAM. OF CUTTING CIRCLE				
DIAMETER OF FEED ROLLERS				
HEIGHT OF TABLE FROM FLOOR	36"	.914 MET.	36"	.914 MET.
FOUR HEAD MACHINE :-				
APPROXIMATE GROSS WEIGHT	4704 LBS	2134 KILOS.	5544 LBS.	2515 KILOS.
NETT WEIGHT	4256 LBS	1930 KILOS.	4956 LBS.	2248 KILOS.
MEASUREMENTS	131 CU.FT.	3.71 CU. MET.	188 CU.FT.	5.33 CU. MET.

INSTALLATION.

WHEN LIFTING MACHINE FROM VEHICLE INTO YOUR WORKS, MAKE SURE THAT THE CHAIN SLINGS OR ROPES ARE SUITABLE TO LIFT THE GIVEN WEIGHT OF THE MACHINE. IT IS ADVISABLE TO INSERT WOODEN PACKINGS OR SACKING BETWEEN THE CHAINS AND THE MACHINE FRAME, ETC., TO OBVIATE PHYSICAL AND PAINT DAMAGE.

FIXING.

A FOUNDATION DRAWING WILL HAVE BEEN SUPPLIED AND NO DOUBT THE MACHINE FOUNDATION WILL HAVE BEEN PREPARED, LEAVING HOLES 4" SQUARE TO RECEIVE THE FIXING BOLTS. MOVE THE MACHINE INTO POSITION OVER THE FOUNDATION, RAISED UP SO THAT THE FIXING BOLTS CAN BE SUSPENDED THROUGH THE BOLT HOLES OF THE MACHINE. LOWER THE MACHINE INTO POSITION AND LEVEL VERY CAREFULLY WITH AN ACCURATE SPIRIT LEVEL, EMPLOYING STEEL OR HARDWOOD WEDGES AS PACKINGS. LEVEL IN AT LEAST TWO POSITIONS ON THE MACHINE TABLE, SAY THE TABLE SURFACE BEFORE THE FEED SYSTEM AND THE SECTION OF TABLE UNDER A TOP CUTTERHEAD. LINE UP THE FEED MOTOR PULLEY WITH THE DRIVEN PULLEY ON THE GEAR BOX. FINALLY GROUT THE BASE AND FOUNDATION BOLT HOLES WITH CEMENT. DO NOT TIGHTEN THE FIXING BOLTS UNTIL THE CONCRETE IS ABSOLUTELY HARD AND BEFORE RE-CHECKING THE LEVEL OF THE MACHINE.

ON A.C. SUPPLY. THE MOTORS ARE FITTED WITH EITHER DIRECT-ON OR STAR-DELTA STARTERS ACCORDING TO REQUIREMENTS, NO-VOLT AND OVERLOAD FEATURES BEING PROVIDED. THE STARTERS ARE INTERLOCKED SO THAT, IN THE EVENT OF ANY HEAD MOTOR CUTTING OUT, THE FEED MOTOR AUTOMATICALLY STOPS. THE STARTERS ARE BUILT INTO A FLOOR-MOUNTING CONSOLE TYPE PANEL SEPARATE FROM THE MACHINE. THE FOUNDATION PLAN SHOWS ONE SUGGESTED POSITION FOR THE STARTING PANEL, AND THIS MAY BE VARIED TO SUIT LOCAL REQUIREMENTS. (THE SWITCHGEAR IS MOUNTED SEPARATELY ON SAGAR MOULDING MACHINES FOR EASE OF ACCESS, TO LIMIT DANGER AND TO ENABLE THE MOST ROBUST AND STANDARD SWITCH UNITS TO BE USED). CONTROL FOR EACH HEAD, START AND STOP FOR FEED, MASTER ISOLATOR AND STOP ARE ALL INCLUDED IN THE PANEL. IN ADDITION, A SEPARATE PUSH BUTTON STATION MOUNTED ON THE MACHINE GIVES START AND STOP FOR THE FEED AS WELL AS FORWARD AND REVERSE INCHING BUTTONS FOR USE WHEN SETTING UP, ETC.

AN ELECTRICALLY DRIVEN MACHINE GIVES EASY AND FINGER-TIP CONTROL, MAY BE PLACED IN ANY POSITION AND GENERALLY GIVES TROUBLE-FREE SERVICE. IN RETURN, IT DEMANDS REGULAR ATTENTION AND EXAMINATION, WITH PARTICULAR REFERENCE TO STARTER CONTACTS TO BE CLEANED, MOTORS THOROUGHLY BLOWN OUT, ETC.

LUBRICATION.

LUBRICATION CHART (FIG.2) AND COMBINED FOUNDATION AND LUBRICATION DRAWING ALREADY SENT, GIVES ALL THE LUBRICATING POINTS, WITH DESCRIPTION OF EACH, WHETHER GREASE OR OIL, AND SUGGESTED PERIOD OF LUBRICATION. WE SUPPLY OUR SPECIAL BALL BEARING GREASE IN 1 CWT. DRUMS OR 1 LB. CARTONS AND STRONGLY RECOMMEND ITS USE WITH OUR MACHINES. PROPRIETARY BRANDS EQUIVALENTS ARE GIVEN ON LUBRICATION CHART, WHERE IT IS NOT POSSIBLE TO OBTAIN OUR OWN.

WE RECOMMEND THE COMBINED FOUNDATION AND LUBRICATION DRAWING BE PASTED ON A BACKBOARD, AS REQUESTED ON IT, AND LEFT NEAR THE MACHINE FOR EASY AND PERIODIC REFERENCE.

REMEMBER THE LESS OBVIOUS POINTS OF LUBRICATION AS WELL AS THOSE IN FULL VIEW - PARTICULARLY IN THE FEED-GEAR.

ALL ROTATING SHAFTS ON SAGAR MOULDERS ARE ON BALL BEARINGS. WE PROVIDE THIS INVALUABLE FEATURE FOR YOUR GOOD: SEE THAT YOU HELP YOURSELF BY WATCHING LUBRICATION.

LIST OF BALL BEARINGS ON SAGAR MOULDERS AND PLANERS "AGC" ARE ACCORDING TO THE ATTACHED LIST AND SIZES, USING HOFFMAN ENGLISH BALL BEARING SYMBOLS.

FEED-GEAR

SIX RATES OF FEED ARE OBTAINABLE BY MEANS OF THREE-SPEED GEARBOX WITH THE TWO-STEP VEE DRIVE FROM THE FEED MOTOR.

VARIATIONS FROM STANDARD FEED SPEEDS CAN BE MADE TO SUIT CUSTOMER'S REQUIREMENTS.

ALL FEED-GEAR SHAFTS, INCLUDING THOSE CARRYING THE FEED ROLLERS, ARE ON BALL BEARINGS. ALL REDUCING GEARS ARE INSIDE THE GEAR-BOX AND RUN IN OIL EXCEPT THE FINAL CHAIN REDUCTION DRIVE WHICH HAS A DRIP FEED LUBRICATOR. WHEN RUNNING, THE LATTER SHOULD ALWAYS BE KEPT OPEN AND FULL. DRIP FEED LUBRICATOR IS ALSO PROVIDED TO THE FEED ROLL CONNECTING GEARS, AND SHOULD BE KEPT FULL AND OPEN WHEN WORKING THE MACHINE.

THE WHOLE GEAR-BOX IS MOUNTED ON A VERTICAL SLIDE WITH FOUR LOCKING NUTS AND JACKING SCREW UNDERNEATH: THIS PROVIDES AN IDEAL AND SIMPLER ARRANGEMENT FOR TENSIONING THE CHAIN REDUCTION DRIVE. ACCESS TO THE LATTER IS OBTAINED BY MEANS OF THE HINGED DOOR (A, FIG.3) AT THE REAR OF THE MACHINE. IT WILL BE NOTICED THAT THE HOLES IN THE BODY THROUGH WHICH THE FEED-ROLLER HOUSINGS PASS ARE SEALED BY RUBBER GAITERS HELD IN POSITION BY METAL GASKETS. THESE SHOULD BE RENEWED WHEN WORN, AS THEY COMPLETELY PROTECT THE CHAIN REDUCTION DRIVE FROM CHIPPINGS, ETC.

THE TOP FEED ROLLERS ARE RAISED AND LOWERED BY THE LARGE HANDWHEEL (A, FIG.1), WHICH IS IN A POSITION CONVENIENT FOR THE OPERATOR'S LEFT HAND. WHEN THE FEED ROLLERS ARE IN CONTACT WITH THE TIMBER, INCREASED PRESSURE IS APPLIED BY SIMPLY CONTINUING TO TURN THE HANDWHEEL IN A DOWNWARD DIRECTION. THIS COMPRESSES TWO LARGE COIL SPRINGS, ONE ON EACH OF THE TWO BARS SUPPORTING THE TOP ROLLERS. INDEPENDENT ADJUSTMENT OF THESE SPRINGS MAY BE MADE BY MEANS OF THE STAR LOCKING NUTS ACCESSIBLE THROUGH THE PANEL (U, FIG.1.) AT THE FEED END.

ALL FEED ROLLERS ARE READILY REMOVABLE, BEING LOCKED IN POSITION BY SQUARE HEAD SCREWS.

FEED-GEAR (CONTINUED)

THE BOTTOM FEED ROLLERS MAY BE RAISED OR LOWERED (ACCORDING TO THE AMOUNT OF PROTRUSION REQUIRED ABOVE THE TABLE LEVEL ON THE CLASS OF TIMBER BEING MACHINED) BY MEANS OF THE HANDWHEEL (B, FIG.3) WHICH IS PROVIDED WITH A LOCKING SCREW. INDEPENDENT LEVELLING ADJUSTMENT CAN BE MADE TO EACH BOTTOM ROLLER BY SQUARE HEAD SCREWS AND LOCK NUTS INSIDE THE FEED CASING. ACCESS TO THESE, AS WELL AS TO THE BEVEL GEARS OPERATING RISE AND FALL OF TOP ROLLERS, IS OBTAINED BY REMOVING THE PLATEN BETWEEN THE BOTTOM ROLLERS (V, FIG.1).

THE BOTTOM FEED ROLLERS ARE SET LEVEL WITH EACH OTHER BEFORE THE MACHINE LEAVES OUR WORKS. THEY CAN THEN BE ADJUSTED BY THE OPERATOR BY HANDWHEEL (B, FIG.3), ACCORDING TO REQUIREMENTS. WHEN WORKING HARDWOODS OR DRY SOFT WOODS, THE ROLLER NEED ONLY BE SET A SMALL FRACTION ABOVE THE LEVEL OF THE PLATEN BEFORE BOTTOM HEADS, BUT IF THE TIMBER IS WET THEN IT MAY BE NECESSARY TO SET THE ROLLER ABOVE THIS PLATEN, EVEN UP TO AS MUCH AS 1/16". IF WHEN FEEDING SOME TYPES OF MATERIAL THE OPERATOR WISHES TO GIVE A SLIGHT DOWNWARD LEAD FROM THE FEED ROLLERS TO THE PLATEN BEFORE BOTTOM HEAD, THEN THIS CAN EASILY BE ACCOMPLISHED. REMOVE PLATEN BETWEEN BOTTOM FEED ROLLERS (V, FIG.1) AND USING ADJUSTING SCREW PROVIDED LIFT THE FIRST BOTTOM FEED ROLLER SLIGHTLY ABOVE THE SECOND, USUALLY NOT MORE THAN 1/16". REMEMBER TO LOCK UP THE SCREW WITH THE LOCKNUT PROVIDED. THIS SOMETIMES HAS A BENEFICIAL EFFECT ON FEEDING AND PLANING FROM FIRST BOTTOM HEAD, BUT IT CAN ALSO COMPRESS TIMBER DOWNWARDS AND DEDUCT FROM THE ADVANTAGES OF THE FIRST BOTTOM HEAD, AS A SURFACING OR PLANING HEAD.

WE ACCORDINGLY PREFER TO DRAW ATTENTION TO THIS FACT IN THESE INSTRUCTIONS, SHOWING THAT FULL PROVISION IS MADE FOR ANY TYPE OF FEED ROLLER SETTING, BUT DESPATCHING MACHINES FROM OUR WORKS WITH THE NORMAL CONVENTIONAL TYPE OF HORIZONTAL LEVEL SETTING.

THE TABLE BEFORE THE BOTTOM HEAD IS ADJUSTABLE VERTICALLY FOR VARYING THE DEPTH OF CUT ON THE BOTTOM HEAD, BY VERTICAL SCREW, ALSO PROVIDED WITH A LOCKNUT. THE PLATEN IS A LIVE PIECE AND HAS HORIZONTAL ADJUSTMENT TO AND FROM THE CUTTERBLOCK.

CUTTERBLOCKS.

THE STANDARD CUTTERBLOCKS SUPPLIED WITH THE MACHINE ARE OUR SQUARE LIPPED TYPED, THOUGH OF COURSE OTHER TYPES ARE AVAILABLE TO SUIT USER'S REQUIREMENTS. THEY ARE ALL OF THE OVERHUNG TYPE FOR EASY ACCESS AND REMOVAL IN SETTING UP, CHANGING HEADS, ETC. IT IS ADVANTAGEOUS TO HAVE ONE OR TWO SPARE CUTTERBLOCKS AND CONICAL SLEEVES ON HAND TO FACILITATE CHANGE-OVER.

EACH BLOCK IS MOUNTED ON TWO SELF-CENTRING CONICAL SLEEVES, ONE AT EACH END, PROVIDED WITH A DRIVING KEY TO PREVENT SLIP ON THE SPINDLE, AND LOCKED ON THE SPINDLE BY A LARGE HEXAGON HARDENED NUT, THREADED DIRECT ONTO THE SPINDLE. ON THE 4" MACHINE, THE SPINDLES ARE 1/2" DIAMETER AND ON THE 7" MACHINE, 3/4" DIAMETER AND THE BLOCKS ON THE RESPECTIVE MACHINES ARE ALL INTERCHANGEABLE.

ALL BLOCKS ARE DYNAMICALLY BALANCED BEFORE LEAVING OUR WORKS. ALL CUTTERS AND CUTTERBLOCKS MUST BE PAIRED AND BALANCED MOST CAREFULLY TO ENSURE SWEET RUNNING. IT MUST BE REMEMBERED THAT THE HIGH SPEEDS IN MODERN WOODWORKING MACHINERY DEMAND THE UTMOST CARE AND ATTENTION TO BALANCE: NEGLECT OF THIS IMPORTANT DUTY CAN CAUSE NOT ONLY BAD FINISH OF THE WORK PRODUCED, BUT BEARING TROUBLE AND BREAKDOWNS.

WE SUPPLY BALANCING STANDS WHICH ARE SIMPLE TO OPERATE.

BOTTOM HEAD ASSEMBLY.

THE BOTTOM HEAD IS MOUNTED IN ACCORDANCE WITH NORMAL BRITISH PRACTICE, I.E. IMMEDIATELY AFTER THE FEED ROLLERS, AND IS USED MAINLY AS A CLEANING UP OR SURFACING HEAD. THUS IT SUITS THE APPROVED METHOD OF WORKING - PLANING, FACE DOWN, AND MOULDING, FACE UP.

ONLY SELDOM IS THIS HEAD USED FOR MOULDING PURPOSES AND THEN USUALLY WHEN THE PARTICULAR JOB IN HAND CANNOT BE WORKED ON ANOTHER HEAD OR THE MACHINE IS NOT FITTED WITH A SECOND BOTTOM OR BEADING HEAD. THE BOTTOM HEAD HAS HORIZONTAL MOTION IN ITS SLEEVE MOUNTING AND RISE AND FALL MOTION BY MEANS OF ITS ECCENTRIC MOUNTING, OPERATED BY WORM AND TOOTHED QUADRANT. THE TABLE OR PLATEN IN FRONT OF THE BOTTOM HEAD HAS RISE AND FALL MOTION FOR VARIATION OF DEPTH OF CUT. BOTH THIS TABLE AND THE ONE IMMEDIATELY AFTER THE HEAD HAVE HORIZONTAL MOTION (IN DIRECTION OF FEED, FOR ADJUSTMENT TO SUIT THE CUTTER PROJECTION. THE LOCKING DEVICE FOR ALL THESE MOVEMENTS SHOULD BE CAREFULLY NOTED AND ALWAYS SECURED BEFORE COMMENCING TO WORK THE MACHINE.

SIDE HEADS.

THESE HEADS ARE CARRIED IN SLEEVE MOUNTINGS ON VERY WIDE AND STABLE HORIZONTAL VEE SLIDES.

THEY ARE PROVIDED WITH HORIZONTAL MOTION ALONG THE SLIDES (S, FIG.1.) BY HANDWHEEL AND SCREW AND ALSO VERTICAL MOTION BY HANDWHEEL AND SCREW. THE SIDE HEADS ARE STAGGERED, THE FENCE HEAD LEADING BY $4\frac{1}{2}$ " ON THE FRONT SIDE HEAD.

TOP HEADS.

THE MACHINE IS SUPPLIED WITH EITHER ONE OR TWO TOP HEADS. IN THE SINGLE TOP HEAD MACHINE, THE HEAD IS MOUNTED IMMEDIATELY AFTER THE SIDE HEADS. IN THE DUAL TOP HEAD MACHINE, THE SECOND TOP HEAD IS "INSERTED" BETWEEN THE FIRST BOTTOM HEAD AND THE SIDE HEADS. IT WILL THUS CLEAN UP OR THICKNESS TIMBERS BEFORE PRESENTATION TO THE SIDE HEADS, OR HELP TO RELIEVE THE FOLLOWING TOP HEAD IN THE WORKING OF HEAVY MOULDINGS. IN ADDITION, AS THE FRONT SIDE HEAD WORKS THE BULK OF THE SIDE HEAD MOULDINGS, THE TIMBER IS THUS PLANED ON BOTTOM, TOP AND ONE SIDE BEFORE THE FRONT SIDE HEAD OPERATES. BETTER AND SMOOTHER WORK RESULTS FROM THIS LOGICAL METHOD OF OPERATING.

SECOND TOP HEAD IS PROVIDED WITH A WIDE LEAD INSERT LET INTO THE TABLE OF THE MACHINE, IMMEDIATELY UNDERNEATH. THESE INSERTS ARE INVALUABLE WHEN RUNNING DELICATE MOULDINGS OR MOULDS IN MULTIPLES, WHERE CUTTERS MAY BE REQUIRED TO PROJECT THROUGH THE TIMBER AND CAN THUS SIMPLY CUT INTO THE LEAD WITHOUT DAMAGE.

EXTRA BOTTOM OR BEADING HEAD - GENERAL NOTES ON ADAPTATION.

THIS HEAD, WHEN FITTED, IS MOUNTED ON THE OUT FEED END OF THE MACHINE IMMEDIATELY AFTER THE SECOND OR CONVENTIONAL TOP HEAD (SEE FIG.5), THE HEAD HAS ECCENTRIC RISE AND FALL MOTION AND HORIZONTAL ADJUSTMENT SIMILAR TO THE FIRST BOTTOM HEAD. FOR ADJUSTMENT OF DEPTH OF CUT, ETC., THE TABLE AFTER THIS HEAD HAS RISE AND FALL MOTION OPERATED BY HANDWHEEL FROM THE SQUARE ON THE END OF SHAFT (C, FIG.5). THE TABLE IS ALSO MOUNTED ON A VERTICAL HINGE (H, FIG.5), ON WHICH IT MAY BE SWUNG COMPLETELY CLEAR FOR ACCESS TO THE CUTTERBLOCK, SAWS, ETC. THIS MOTION IS SECURED BY LOCKNUT (G, FIG.5). THE TABLE IS PROVIDED WITH AN ADJUSTABLE PLATEN (B, FIG.5) FOR ADJUSTMENT TO SUIT CUTTER PROJECTION. THE PORTION OF THE MACHINE-BED IN FRONT OF THIS HEAD IS PURPOSELY MADE OF HARDWOOD TO PROVIDE EASY CHANGE. THE VARIETY OF WORK DONE ON THIS HEAD IS SUCH THAT NO BETTER MATERIAL THAN HARDWOOD CAN BE FOUND FOR THIS PORTION OF THE MACHINE-BED, WHICH IS OFTEN CUT INTO BY SPLITTING SAWS, ETC.

VERTICAL THROATING HEAD.

WHEN REQUIRED, THE MACHINE CAN BE SUPPLIED WITH A VERTICAL THROATING HEAD (J, FIG.5). THIS IS MOUNTED ON A HORIZONTAL SLIDE IMMEDIATELY AFTER THE CONVENTIONAL OR SECOND TOP HEAD. IT COMPRISES A MOTORISED VERTICAL CUTTERHEAD WITH HORIZONTAL MOVEMENT ACROSS THE WHOLE WIDTH OF BED BY HANDWHEEL AND SCREW (E, FIG.5). THIS HEAD ALSO HAS RISE AND FALL MOTION BY HANDWHEEL AND SCREW (D, FIG.5) AND CANTING MOTION UP TO 30 DEGREES EITHER SIDE OF THE VERTICAL, WITH LOCKING MOTION (F, FIG.5). THIS HEAD WITH ITS UNIVERSAL MOVEMENTS IS EXTREMELY USEFUL WHEN MACHINING UNDERCUT MOULDINGS AND SUCH JOBS AS WEATHER GROOVING IN SILLS, ETC., WHICH CANNOT BE REACHED BY THE CONVENTIONAL HORIZONTAL OR VERTICAL HEADS.

FENCES.

THESE ARE ADJUSTABLE TRANSVERSELY FOR DEPTH OF CUT ON THE FENCE SIDE HEAD. THEY ARE ALSO ADJUSTABLE LONGITUDINALLY TO SUIT THE CUTTER PROJECTION ON THE FENCE SIDE HEAD.

THE FENCES ARE CUT AWAY WHERE THEY PASS BENEATH THE TWO TOP FEED ROLLERS. THEY ARE ALSO CUT AWAY WHERE THEY PASS THE BOTTOM AND TOP HEADS. THIS PROVIDES CLEARANCE FOR CUTTERS WHICH WOULD OTHERWISE FOUL THE FENCES. PROVISION IS MADE FOR HARDWOOD INSERTS TO BE SCREWED IN POSITION WHERE THE FENCES ARE RELIEVED FOR THE CUTTERS, TAPPED HOLES BEING PROVIDED FOR THE PURPOSE.

PRESSURES - INTRODUCTORY.

THE PRESSURES ON THESE MOULDING AND PLANING MACHINES ARE A COMBINATION OF SPRING LOADED ROLLER AND WOODEN SHOED TYPE, WITH FENCE OR FIXED TYPE PRESSURES AFTER THE TIMBER HAS BEEN PLANED. IN DESCRIBING THE VARIOUS PRESSURES COMMENCEMENT IS MADE AT THE FEEDING-IN END OF THE MACHINE. AS WITH ALL THE FEATURES IN OUR MACHINES, OUR PRESSURES ARE DESIGNED TO MEET THE MAXIMUM VARIETY OF WORK POSSIBLE, FROM THE SMALLEST OF MOULDINGS, OFTEN ONLY A FRACTION OF A SQUARE INCH IN SECTION, TO MATERIAL UP TO THE MAXIMUM CAPACITY OF THE MACHINE.

PRESSURES - IN-FEED TABLE.

TWO SPRING-LOADED BALL BEARING SIDE PRESSURES ARE PROVIDED BEFORE AND IMMEDIATELY AFTER THE FEED ROLLERS. THEY ARE ADJUSTABLE ACROSS THE FULL WIDTH OF THE MACHINE BED, ARE PROVIDED WITH STRONG LOCKS AND HAVE SCREW OPERATED TENSION FOR THE SPRINGS.

HERE IT MAY BE MENTIONED THAT A HINGED COVER COMPLETELY HOUSES THE TOP FEED ROLLERS AND IS PROVIDED WITH A HEIGHT GAUGE OR GATE ADJUSTABLE TO THE DEPTH OF TIMBER ENTERING THE FEED SYSTEM.

PRESSURES - BOTTOM HEAD.

A HEAVY DUAL BALL BEARING SPRING-LOADED PRESSURE IS MOUNTED OVER THE BOTTOM HEAD (L, FIG.1), ON A VERTICAL STEEL PILLAR AND WITH RISE AND FALL MOTION BY HANDWHEEL AND SCREW (T, FIG.1). SCREW ADJUSTMENT FOR THE SPRINGS IS PROVIDED. FOR NARROW STOCK, AN EXTRA PRESSURE, INTERCHANGEABLE WITH THE ABOVE, IS PROVIDED. THIS IS SIMILAR TO THE HEAVIER PRESSURE EXCEPT THAT IT HAS $\frac{1}{2}$ " WIDE ROLLERS ONLY, OVERHANGING ON THE FENCE SIDE OF THE PRESSURE UNIT. THIS PRESSURE ENABLES THE SMALLEST SECTIONS OF MOULDS, ETC. TO BE ACCOMMODATED WITH COMPLETE EASE AND CONVENIENCE.

PRESSURES - FIRST (EXTRA) TOP HEAD.

THE TOP PRESSURE ON THIS HEAD IS OF THE RADIAL CHIPBREAKER TYPE, FORMED INTEGRALLY WITH THE EXHAUST HOOD. IT IS WEIGHT LOADED WITH DETACHABLE WEIGHTS WHICH MAY BE REMOVED OR ADDED ACCORDING TO THE WORK IN HAND. CONTACT WITH THE TIMBER IS MADE BY STEEL SHOES WHICH MAY BE READILY REMOVED AND REPLACED, IF REQUIRED, BY HARDWOOD SHOES. ACCORDING TO THE OVERHANG OF THE CUTTERS, THE BEAM CARRYING THE STEEL SHOES MAY BE ADJUSTED TO AND FROM THE CUTTING CIRCLE OR CANTED IN GROOVED SLOTS. THIS IS A MOST USEFUL FEATURE ON CERTAIN CLASSES OF JOINERY WORK WHERE THE GENERAL FORM OF THE MOULDING MAY BE TAPER AND LARGE OVERHANGS OF CUTTER SET-UPS ARE REQUIRED.

PRESSURES - SIDE HEADS.

A SINGLE BALL BEARING PRESSURE, SIMILAR TO, BUT NARROWER THAN THAT OVER THE BOTTOM HEAD, IS MOUNTED OVER THE TIMBER BETWEEN THE SIDE HEADS. IT IS TO BE NOTED THAT THIS ROLLER PRESSURE MAY BE CANTED FOR BEVEL WORK. ON VERY NARROW OR DELICATE MATERIAL, THE ROLLER UNIT OF THIS PRESSURE MAY BE REMOVED AND REPLACED BY A HARDWOOD FINGER. IN FRONT OF THE FRONT SIDE HEAD, A RADIAL SPRING-LOADED CHIPBREAKER TYPE OF PRESSURE IS PROVIDED FITTED WITH AN ADJUSTABLE STEEL SHOE (K, FIG.1). THE ALUMINIUM EXHAUST HOOD SWIVELS WITH THIS PRESSURE.

PRESSURES - CONVENTIONAL OR SECOND TOP HEAD.

THE PRESSURES ASSOCIATED WITH THIS HEAD ARE THE SAME AS ON THE FIRST OR EXTRA TOP HEAD, EXCEPT THAT AS THE MATERIAL, AT THIS STAGE, HAS ALREADY BEEN PLANED TO WIDTH BY THE SIDE HEADS, THE SIDE PRESSURES ARE OF THE SOLID FENCE TYPE WITH PROVISION FOR FITTING WOODEN SHOES (I, FIG.1). TOP PRESSURES AFTER BOTH TOP HEADS ARE THE SAME, EACH COMPRISING A PLUNGER TYPE PRESSURE MOUNTED ON A BEAM IMMEDIATELY AFTER THE HEAD AND TO WHICH IT CAN BE LOCKED BY A STRONG LOCKING BOLT. IT IS FITTED WITH DETACHABLE WOODEN SHOES, HAS RISE AND FALL MOTION BY HANDWHEEL AND SCREW AND IS SPRING-LOADED TO PREVENT BINDING.

PRESSURES - SECOND BOTTOM OR BEADING HEAD.

FENCE TYPE ADJUSTABLE SIDE PRESSURES ARE PROVIDED WITH THE USUAL MEANS FOR FITTING WOODEN SHOES. THE PRESSURE OVER THIS BOTTOM HEAD IS NOW DIFFERENT FROM THAT ILLUSTRATED, IT IS SIMILAR TO THE PRESSURES AFTER THE TOP HEADS WITH THE SAME MOVEMENTS BUT IS MOUNTED ON A STRONG STEEL BAR WITH VERTICAL ADJUSTMENT BY HANDWHEEL AND SCREW. IT BRIDGES THE ENTIRE GAP THROUGH WHICH THE SECOND BOTTOM HEAD OPERATES, AND, HAVING A WIDE AND LONG WOODEN SHOE, A SPLITTING SAW PROTRUDING THROUGH MATERIAL BEING MACHINED, CAN BE ALLOWED TO BITE INTO THE SHOE.

PRESSURES - GENERAL.

OWING TO THE COMPLEXITY AND VARIED SIZES OF WORK PERFORMED ON A FOUR SIDE MOULDER AND PLANER, THE MORE PROVISION THAT IS MADE FOR VERSATILITY IN THE VARIOUS COMPONENTS OF THE MACHINE, THE BETTER. WHEREVER CUTTERS ARE REQUIRED TO OVERHANGE, OVERLAP OR "DIG IN", PRESSURES ON SAGAR MACHINES ARE PROVIDED WITH RENEWABLE WOODEN SHOES. WOOD IS OBVIOUSLY THE MOST PLENTIFUL MATERIAL IN A WOODWORKING SHOP, IT IS EASILY SHAPED AND FITTED FOR A PARTICULAR MOULD AND PROVIDES THE BEST AND SAFEST TYPE OF CHIPBREAKER SHOE. AN OPERATOR MAY THEREFORE USE HIS PERSONAL IDEAS AND INGENUITY TO THE FULL ON THESE MACHINES AT VERY LITTLE EXPENSE AND, ON COMMON OR RECURRENT MOULDS, MAY WISH TO PRESERVE SETS OF WOODEN PRESSURE SHOES FOR PARTICULAR JOBS.

SETTING-UP.

IT IS SURPRISING HOW MUCH TIME CAN BE LOST BY INEFFICIENT SETTING-UP OR BY THE FAILURE OF MACHINES TO PROVIDE ALL POSSIBLE MEANS TO REDUCE THIS IDLE TIME TO A MINIMUM.

OUR AGC MOULDERS HAVE BEEN DESIGNED TO HELP THE OPERATOR AS MUCH AS POSSIBLE TO CHANGE OVER FROM ONE JOB TO ANOTHER WITH THE UTMOST SPEED.

FEED ROLLER, HEAD AND PRESSURE ADJUSTMENTS ARE HANDY AND COMFORTABLE, THE GENERAL ACCESSIBILITY WILL BE FOUND TO BE DELIGHTFUL AND HIGHEST QUALITY OF WORK IS VERY EASILY OBTAINED.

BEING AN "OUTSIDE" MOULDER, ALL HEADS CAN BE READILY REMOVED OR REPLACED AS THERE ARE NO BEARING HOUSINGS TO BE REMOVED BEFOREHAND. FURTHER, AS EACH HEAD IS PROVIDED WITH COMPOUND MOVEMENT, IT IS VERY EASY TO MAKE SLIGHT ADJUSTMENT OF THE POSITION OF THE MOULDED SECTION, EVEN WHILST THE MACHINE IS RUNNING. THIS PARTICULARLY APPLIES TO CUTTERBLOCK SET AWAY FROM THE MACHINE, WHICH OFTEN REQUIRES MINOR ADJUSTMENTS.

WHEN SETTING-UP FOR PLANING.

MAKE FULL USE OF THE LIPS ON THE CUTTERBLOCKS BY SETTING THE CUTTERS WITH A MINIMUM OVERHANG, SAY $1/32$ " PLUS, WHICH GIVES THE STANDARD CUTTING CIRCLE OF THE MACHINE. THIS ENABLES THE LIPS TO ACT LIKE THE BACK IRON IN A JOINER'S PLANE AND PREVENT PLUCKING OF THE SURFACE OF THE TIMBER. METAL TO METAL CONTACT MUST BE MAINTAINED BETWEEN THE CUTTER FACES AND THE EDGES OF THE LIPS, AND, TO ENSURE THIS, IT IS USUAL TO EMPLOY A THIN PAPER PACKING UNDER THE REAR OF THE CUTTERS ONLY. DO NOT PACK UNDER THE CUTTING FACES OF THE CUTTERS OR YOU WILL ENCOURAGE THE INGRESS OF CHIPPINGS WHICH CAN NOT ONLY DAMAGE THE LIPS BUT, ULTIMATELY, CAUSE THE CUTTERS TO BEND - IN WHICH CONDITION THEY ARE DANGEROUS.

WHEN SETTING-UP FOR MOULDING.

THE "HIGHEST" POINT OF THE MOULD, I.E. THE POINT REQUIRING THE LEAST CUTTER OVERHANG, SHOULD BE WORKED BY CUTTERS OPERATING AS NEARLY AS POSSIBLE TO THE STANDARD CUTTING CIRCLE OF THE MACHINE, I.E. JUST CLEAR OF THE LIPS. THIS MINIMIZES CUTTER OVERHANG GENERALLY. MOULD CUTTERS CAN BE GROUND VERY ACCURATELY "BY EYE" BY MANY MACHINE-MEN BUT, IF EXACT SHAPES ARE REQUIRED, THEN A TEMPLATE OF THE MOULD CUTTERS SHOULD BE MADE (IN CARD, OR IN SAY 18 S.W.G. ALUMINIUM) BY GEOMETRIC PROJECTION. A HARDWOOD SAMPLE OF THE MOULDS TO BE PRODUCED IS VERY USEFUL WHEN SETTING-UP EITHER ON OR AWAY FROM THE MACHINE. AT THE SAME TIME, IT IS NOT INDISPENSABLE PROVIDED THE CUTTERS ARE ACCURATELY GROUND AND GEOMETRIC PROJECTION PROPERLY APPLIED.

THE HEADS ARE BEST SET UP PROGRESSIVELY THROUGH THE MACHINE, COMMENCING WITH THE FIRST BOTTOM HEAD, SIMILARLY, WHEN THE CUTTERBLOCK SET-UP HAS BEEN COMPLETED AND THE HEADS PROPERLY POSITIONED, THE FIRST TIMBER ENTERING THE MACHINE MUST BE "INCHED" FORWARD BY THE PUSH-BUTTON PROVIDED FOR THE PURPOSE. THIS PROGRESSIVE ENTRY PERMITS THE ADJUSTMENT OF THE PRESSURES ONE BY ONE.

THE CHOICE OF FEED-SPEED DEPENDS UPON THE SIZED CLASS OF TIMBER BEING HANDLED, AND THE "FINISH" REQUIRED. FINISH DEPENDS UPON THE NUMBER OF CUTTERMARKS PER UNIT LENGTH. MATHEMATICALLY THE NUMBER OF CUTTERMARKS IS PROPORTIONATE TO THE REVOLUTIONS PER MINUTE AND TO THE NUMBER OF CUTTERS CONTRIBUTING TO THE FINISH ON ONE PORTION OF THE MOULD : ALSO THE FINISH IS INVERSELY PROPORTIONATE TO THE FEED SPEED. THE FORMULA EXPRESSING THIS IN MORE DIRECT TERMS AS FOLLOWS :-

IF M = NUMBER OF CUTTERMARKS PER INCH
F = FEED SPEED IN FEET PER MINUTE.
R = R.P.M. OF THE CUTTERBLOCK
C = NUMBER OF CUTTERS FINISHING

$$\text{THEN } M = \frac{R \times C}{F \times 12}$$

THUS, AT 40FT. PER MINUTE ON THE AGC 4" MACHINE WITH HEADS RUNNING AT 6000 R.P.M. AND WITH A SINGLE (BUT BALANCED) CUTTER FINISHING :

$$\begin{aligned} \text{THE NUMBER OF CUTTERMARKS PER 1" } &= \frac{6,000 \times 1}{12 \times 40} \\ &= 12\frac{1}{2} \end{aligned}$$

A WORD OF EXPLANATION OUGHT TO BE ADDED HERE ABOUT " CUTTERS FINISHING". IT IS GOOD PRACTISE TO GRIND, BALANCE, MATCH AND MOUNT CUTTERS IN PAIRS ALTHOUGH A GOOD OPERATOR OFTEN WORKS WITH A SINGLE CUTTER GROUND TO THE OUTLINE OF MOULD REQUIRED AND USES A DUMMY IRON OF APPROXIMATELY THE SAME GENERAL DIMENSIONS, BUT ACCURATELY BALANCED WITH THE GROUND CUTTERS.

WHEN MOUNTED IN POSITION, THE SINGLE CUTTER ALONE IS RESPONSIBLE FOR CUTTING THE MOULDER AND THE FINISH OBTAINED, I.E., THE NUMBER OF CUTTERMARKS PER INCH.

WHEN A PAIR OF MATCHED CUTTERS IS MOUNTED AND ACCURATELY SET, IT IS VERY SELDOM THAT THEY BOTH CONTRIBUTE TO THE FINISH. THE SETTING OF THE CUTTERS DEPENDS ON THE EYESIGHT OF THE OPERATOR AND A VARIATION OF THE SETTING OF ONE COMPARED WITH ANOTHER OF ONLY A MICROSCOPIC AMOUNT IS SUFFICIENT TO EFFECT THEIR EVEN CONTRIBUTION TO THE WORK. BOTH CUTTERS MAY BE CUTTING BUT, MORE OFTEN THAN NOT, THE CUTTERMARKS OF ONE CUTTER ARE OBLITERATED BY THE CUTTERMARKS OF THE OTHER, WHICH HAS A FRACTION GREATER OVERHANG.

IN MACHINES OF HIGH SPEED SPINDLE TYPE, THIS FACT IS ACCEPTED, AND "SINGLE POINT FINISH" IS THE APPROVED METHOD OF WORKING.

NOTES FOR THE OPERATOR.

- (1) BE METICULOUS IN THE BALANCE OF CUTTERS AND CUTTERBLOCKS.
- (2) MAKE SURE THE CUTTERS ARE PROPERLY SECURED.
- (3) NEVER PACK UNDER THE LEADING EDGES OF THE CUTTERS AND DO NOT USE THICK PACKINGS UNDER THE REAR EDGES.
- (4) CONSTANTLY EXAMINE CUTTERS AND CUTTERBOLTS, THE FORMER FOR BENDING, AND THE LATTER FOR FAILURE OWING TO EXCESSIVE TIGHTENING.
- (5) USE REASONABLE MINIMUM PRESSURES THROUGHOUT THE MACHINE: OTHERWISE EXCESSIVE WEAR WILL BE CAUSED ON THE BED AND FENCES AND AN UNNECESSARY LOAD ON THE FEED SYSTEM.
- (6) MAKE SURE THAT "LIFT" IS RETAINED IN THE PRESSURE UNITS INTENDED TO BE FLEXIBLE, I.E. THAT THEY ARE NEVER SCREWED DOWN OR OTHERWISE ADJUSTED TO THE LIMIT.
- (7) WATCH THAT ALL HEADS REVOLVE CLEAR OF THE PRESSURE, ETC. ALLOWING FOR "PRESSURE LIFT" TO ACCOMMODATE VARIATIONS IN THE DIMENSIONS OF THE TIMBER.
- (8) PAY SPECIAL ATTENTION TO LUBRICATION.
- (9) REMEMBER THE SAGAR AGC IS A FIRST CLASS MACHINE AND MERITS FIRST CLASS ATTENTION. IT WILL THEN GIVE CONTINUAL FIRST CLASS SERVICE FOR MANY YEARS.

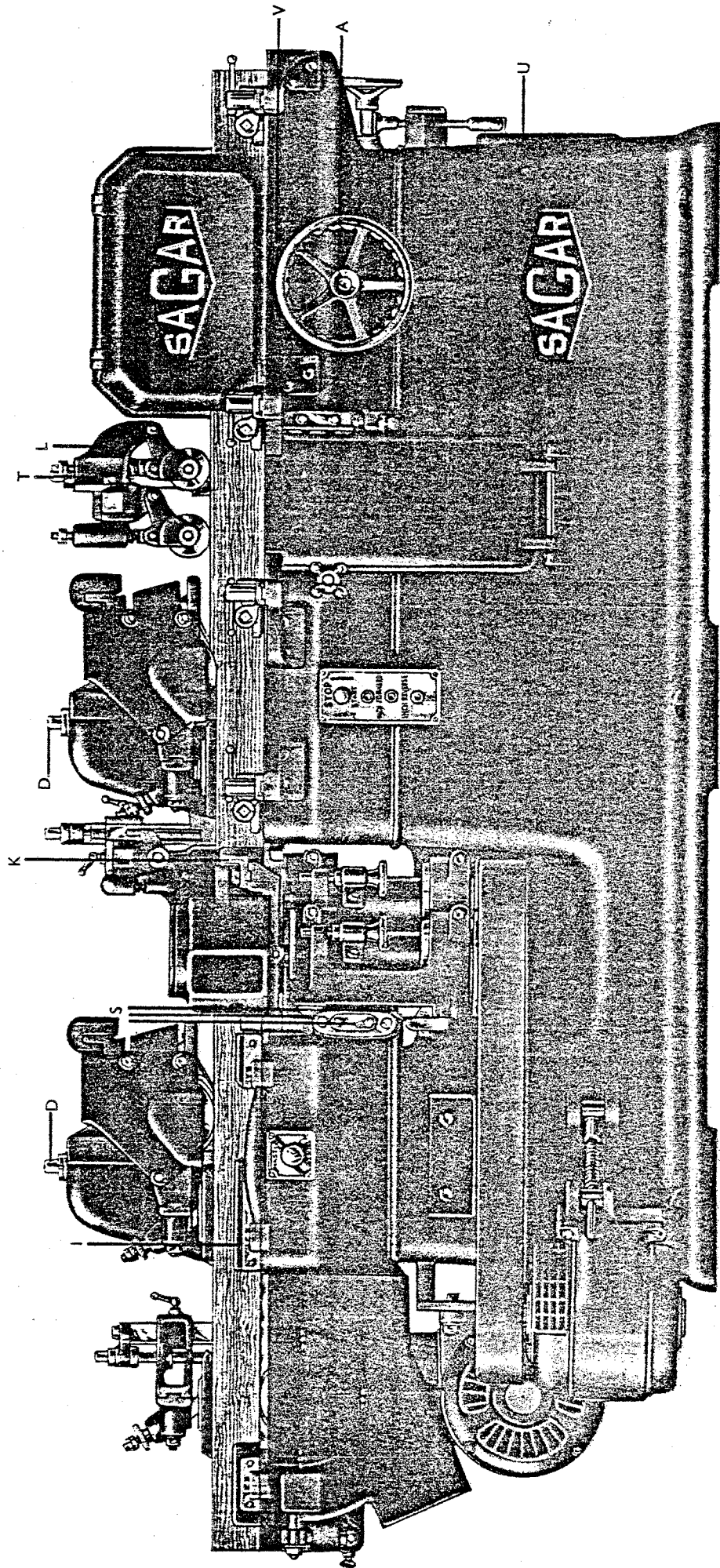

2432

Fig. 1 FRONT VIEW OF MACHINE

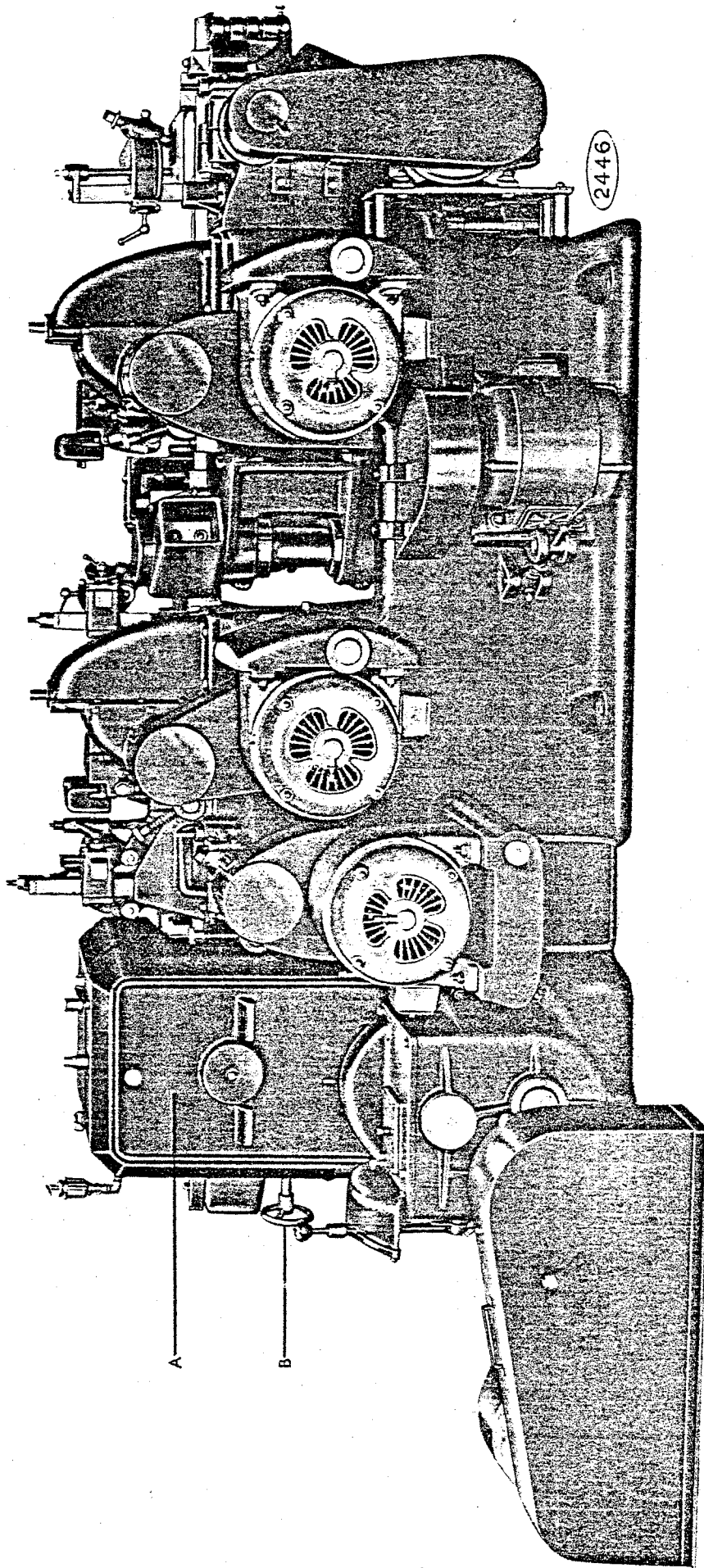

Fig. 3. REAR VIEW OF MACHINE

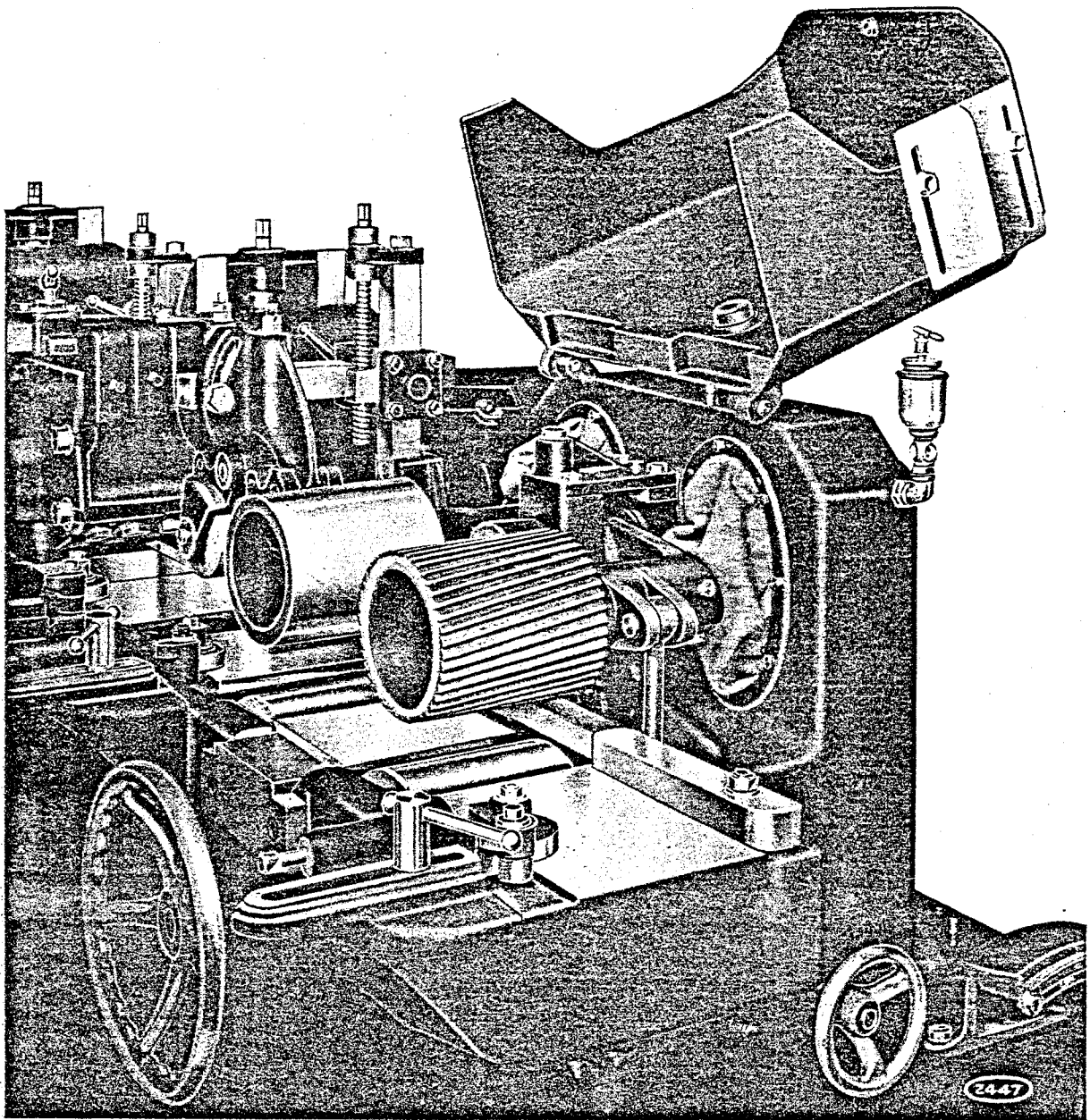

Fig. 4. FEED-IN END OF MACHINE SHOWING FEED ROLLERS

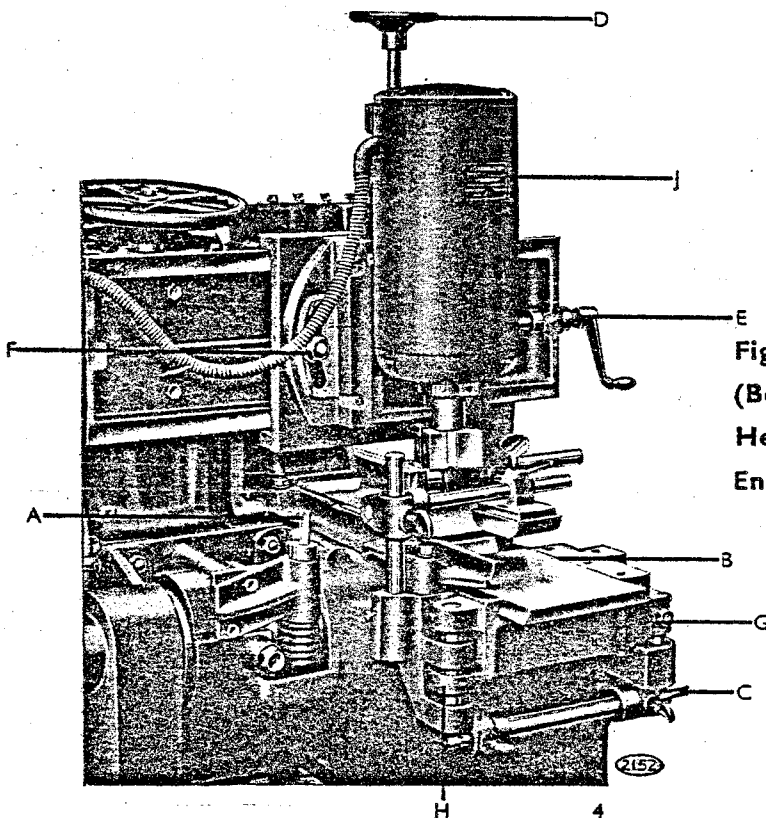

Fig. 5. Additional Bottom (Beading) Head and Throating Head, mounted at Feed-out End of the Machine.